

**REGULAR MEETING OF WASHINGTON, MISSOURI CITY COUNCIL
 MONDAY, FEBRUARY 5, 2024 - 7:00 P.M.
 COUNCIL CHAMBER, 405 JEFFERSON STREET, WASHINGTON, MISSOURI**

**SUGGESTED
 COUNCIL ACTION**

1. INTRODUCTORY ITEMS:

Roll Call / Pledge of Allegiance
 Approval of the Minutes from the January 16 & January 29, 2024, Council Meetings

Need Motion/Mayor Memo

Approval and Adjustment of Agenda including Consent Agenda

Need Motion/Mayor Memo

a. Liquor License Application – underGROUNDS Coffee LLC

2. PRIORITY ITEMS:

Mayor’s Presentations, Appointments & Reappointments

3. PUBLIC HEARINGS:

4. CITIZENS COMMENTS:

5. UNFINISHED BUSINESS:

6. REPORT OF DEPARTMENT HEADS:

a. Missouri Park and Recreation Association’s Citation Award for Organizations – Riverfront Park Playground Project
 b. 2023 Building Report
 c. 2024/2025 MoDOT Traffic Safety Grants

Accept Into Minutes
 Approve/Mayor Memo

7. ORDINANCES/RESOLUTIONS:

a. An ordinance accepting the Proposal from BFA for Professional Services for the Busch Creek Guardrail and Channel Protection Project. Read & Int/Read/Vote/Mayor Memo

b. An ordinance authorizing and directing the execution of a Standard Form of Agreement by and between the City of Washington, Missouri and FGM Architects, Inc and amend the 2023/2024 Budget. Read & Int/Read/Vote/Mayor Memo

c. An ordinance authorizing and directing the execution of a City-Contractor Agreement by and between the City of Washington, Missouri and Sieve Contractors, Inc and amend the 2023/2024 Budget. Read & Int/Read/Vote/Mayor Memo

d. An ordinance authorizing and directing the City of Washington, Missouri to enter into a Sales Contract with Clark Equipment d/b/a Bobcat Company for the purchase of a Bobcat Toolcat UW56 Utility Work Machine with Attachments. Read & Int/Read/Vote/Mayor Memo

e. An ordinance authorizing and directing the City of Washington, Missouri to enter into a Sales Contract with Truck Centers, Inc. for the purchase of a 2-Ton Freightliner 108SD Plus Dump Truck. Read & Int/Read/Vote/Mayor Memo

f. An ordinance authorizing and directing the City of Washington, Missouri to enter into a Sales Contract with Woody’s Municipal Supply Co. for the purchase of a Galion 430U SMS Truck Bed, Snowplow & Salt Spreader. Read & Int/Read/Vote/Mayor Memo

- g. An ordinance repealing Ordinance No. 24-13896 and enacting in lieu thereof an ordinance authorizing and directing the execution of an Agreement for Stray Animal Boarding by and between the City of Washington, Missouri and the Franklin County Humane Society. Read & Int/Read/Vote/Mayor
- h. An ordinance authorizing and directing the execution of a Contract Amendment No. 1 by and between the City of Washington, Missouri and Cochran. Read & Int/Read/Vote/Mayor Memo
- i. An ordinance approving the Boundary Adjustment for Highland Meadows, Plat 9A in the City of Washington, Franklin County, Missouri. Read & Int/Read/Vote/Mayor Memo

8. COMMISSION, COMMITTEE AND BOARD REPORTS:

- a. Downtown Washington Inc. Annual Report Approve/Mayor
- b. An ordinance approving the Final Plat of Stone Bridge, Plat 1 in the City of Washington, Franklin County, Missouri. Read & Int/Read/Vote/Mayor

9. MAYOR’S REPORT:

- a. Second Council Meeting in January – Tuesday, February 20, 2024, due to President’s Day Holiday

10. CITY ADMINISTRATOR’S REPORT:

11. COUNCIL COMMENTS:

12. CITY ATTORNEY’S REPORT:

Public Vote on whether or not to hold a closed meeting to discuss personnel, legal and real estate matters pursuant to Section 610.021 RSMo (2000).

Roll Call Vote

13. INFORMATION:

- a. General Sales Tax Report
- b. Capital Improvement Sales Tax Report
- c. Transportation Sales Tax Report
- d. Local Option Use Tax Report
- e. Budget Report

14. ADJOURNMENT:

NOTICE: COPIES OF THE PROPOSED ORDINANCES ON THIS AGENDA ARE AVAILABLE FOR PUBLIC INSPECTION PRIOR TO THE TIME THE BILL IS UNDER CONSIDERATION BY THE CITY COUNCIL.

POSTED BY SHERRI KLEKAMP, CITY CLERK, FEBRUARY 1, 2024

A COPY OF THIS NOTICE IS ALSO AVAILABLE ONLINE AT www.washmo.gov

**MINUTES OF THE REGULAR MEETING OF THE CITY COUNCIL
CITY OF WASHINGTON, FRANKLIN COUNTY, MISSOURI
TUESDAY, JANUARY 16, 2024**

INTRODUCTORY ITEMS:

The Regular Meeting of the City of Washington, Missouri, City Council was held on Tuesday, January 16, 2024, at 7:00 p.m. in the Council Chamber. Mayor Doug Hagedorn opened the meeting with roll call and Pledge of Allegiance.

| | | |
|--------------------------------|---------------|---------|
| Mayor: | Doug Hagedorn | Present |
| Council Members: Ward I | Al Behr | Present |
| | Duane Reed | Present |
| Ward II | Mark Hidritch | Present |
| | Mark Wessels | Present |
| Ward III | Chad Briggs | Absent |
| | Jeff Patke | Present |
| Ward IV | Mike Coulter | Present |
| | Joe Holtmeier | Present |

| | | |
|----------------------|-------------------------------|--------------------|
| Also Present: | City Attorney | Mark Piontek |
| | City Administrator | Darren Lamb |
| | City Clerk | Sherri Klekamp |
| | Economic Development Director | Sal Maniaci |
| | Police Chief | Jim Armstrong |
| | Emergency Management Director | Justin Frankenberg |
| | Fire Chief | Tim Frankenberg |

Originals and/or copies of agenda items of the meeting, including recorded votes are available on record in the office of the City Clerk. Each ordinance is read a minimum of twice by title, unless otherwise noted.

Approval of Minutes:

* Approval of the Minutes from the January 2, 2024, Council Meeting

A motion to accept the minutes with an amendment regarding Ordinance No. 24-13898; remove the word failed on the following roll call vote and replace it with passed on the following roll call vote made by Councilmember Holtmeier, seconded by Councilmember Behr, passed without dissent.

(Remaining of page intentionally left blank)

Approval and Adjustment of Agenda including Consent Agenda:

* **2020 Landfill Tickets Destruction Request**

January 8, 2024

Honorable Mayor and City Council

City of Washington

Washington, Missouri

RE: Landfill Tickets

Dear Mayor and Council Members:

We are required to keep three years of landfill tickets so with this letter I am asking to destroy tickets from 2020.

If you have any questions or comments please feel free to contact me.

Thank you,

Andrea Lueken

Assistant City Engineer

A motion to accept and approve the agenda including the consent agenda accordingly made by Councilmember Holtmeier, seconded by Councilmember Coulter, passed without dissent.

PRIORITY ITEMS:

Mayor's Presentations, Appointments & Reappointments:

* **Police Department Reappointment**

January 4, 2024

To The City Council

City of Washington

Washington, MO 63090

Dear Council Members:

I herewith submit for your approval the following for reappointment to the Police Department for a second six-month probationary term:

| NAME | TERM BEGINS | TERM ENDS |
|----------------|------------------|----------------------------|
| Max Keeler | January 18, 2024 | July 18, 2024 |
| Police Officer | | (2 nd 6 months) |

A motion to accept and approve the reappointment made by Councilmember Patke, seconded by Councilmember Hidritch, passed without dissent.

PUBLIC HEARINGS

* None

CITIZENS COMMENTS

* None

UNFINISHED BUSINESS

* None

REPORT OF DEPARTMENT HEADS

* None

ORDINANCES/RESOLUTIONS

Bill No. 24-12937, Ordinance No. 24-13901, an ordinance authorizing and directing the execution of an Agreement by and between the City of Washington, Missouri and Flock Group, Inc. for License Plate Reader Cameras and Services.

The ordinance was introduced by Councilmember Holtmeier.

After discussion, the ordinance was read a second time and approved on the following vote; Holtmeier-aye, Reed-aye, Behr-aye, Patke-aye, Wessels-aye, Coulter-aye, Hidritch-nay, Briggs-absent.

Bill No. 24-12938, Ordinance No. 24-13902, an ordinance accepting the Proposal from PNC Equipment Finance for a new Pierce Enforcer Tanker/Pumper Fire Apparatus.

The ordinance was introduced by Councilmember Patke.

After a brief discussion, the ordinance was read a second time and approved on the following vote; Holtmeier-aye, Reed-aye, Behr-aye, Patke-aye, Wessels-aye, Coulter-aye, Hidritch-aye, Briggs-absent.

Bill No. 24-12939, Ordinance No. 24-13903, an ordinance authorizing and directing the City of Washington, Missouri to accept a Contractor Agreement from Go Green Lawn & Landscape LLC for the Highway 100 Median Beds Maintenance.

The ordinance was introduced by Councilmember Holtmeier.

After discussion, the ordinance was read a second time and approved on the following vote; Holtmeier-aye, Reed-nay, Behr-aye, Patke-aye, Wessels-aye, Coulter-aye, Hidritch-aye, Briggs-absent.

Bill No. 24-12940, Ordinance No. 24-13904, an ordinance accepting the Proposal from Wunderlich Surveying and Engineering, Inc. for Engineering Design Services for the Fox Crest Drive Extension Project and amend the 2024 Budget.

The ordinance was introduced by Councilmember Holtmeier.

After a brief discussion, the ordinance was read a second time and approved on the following vote; Holtmeier-aye, Reed-aye, Behr-aye, Patke-aye, Wessels-aye, Coulter-aye, Hidritch-aye, Briggs-absent.

Bill No. 24-12941, Ordinance No. 24-13905, an ordinance amending Schedule IV No Parking At Any Time, of the Code of the City of Washington, Missouri.

The ordinance was introduced by Councilmember Patke.

After a brief discussion, the ordinance was read a second time and approved on the following vote; Holtmeier-aye, Reed-aye, Behr-aye, Patke-aye, Wessels-aye, Coulter-aye, Hidritch-aye, Briggs-absent.

Bill No. 24-12942, Ordinance No. 24-13906, an ordinance amending Schedule XIII Loading and Unloading Zones, of the Code of the City of Washington, Missouri.

The ordinance was introduced by Councilmember Holtmeier.

After a brief discussion, the ordinance was read a second time and approved on the following vote; Holtmeier-aye, Reed-aye, Behr-aye, Patke-aye, Wessels-aye, Coulter-aye, Hidritch-aye, Briggs-absent.

Resolution No. 24-13907, a resolution authorizing the City of Washington, Missouri to apply for funding through the East-West Gateway Council of Governments to provide for the East Fifth Street Roadway and ADA Improvements Project in the City of Washington, Franklin County, Missouri.

The resolution was introduced by Councilmember Behr, seconded by Councilmember Patke. After discussion, the resolution passed.

Resolution No. 24-13908, a resolution authorizing the City of Washington, Missouri to apply for funding through the East-West Gateway Council of Governments to provide for the Front Street ADA Improvements Project in the City of Washington, Franklin County, Missouri.

The resolution was introduced by Councilmember Patke, seconded by Councilmember Holtmeier. After a brief discussion, the resolution passed.

Resolution No. 24-13909, a resolution authorizing the City of Washington, Missouri to apply for funding through the East-West Gateway Council of Governments to provide for the High Street Reconstruction and ADA Improvements Project in the City of Washington, Franklin County, Missouri.

The resolution was introduced by Councilmember Coulter, seconded by Councilmember Patke. After a brief discussion, the resolution passed.

Resolution No. 24-13910, a resolution authorizing the City of Washington, Missouri to apply for funding through the East-West Gateway Council of Governments to provide for the Highway 100/East Fifth Street Intersection Improvements Project in the City of Washington, Franklin County, Missouri.

The resolution was introduced by Councilmember Coulter, seconded by Councilmember Behr. After a brief discussion, the resolution passed.

COMMISSION, COMMITTEE AND BOARD REPORTS

* None

MAYOR'S REPORT

- * Second Council Meeting in February – Tuesday, February 20, 2024, due to President's Day Holiday
- * Thank you for attending today's Coffee with the Mayor.

CITY ADMINISTRATOR’S REPORT

- * Missouri Park & Recreation Association awarded Downtown Washington Inc. an Outstanding Citation for their contribution to the Riverfront Playground. This will be presented to them at the February 5, 2024, Council Meeting.
- * Employee Appreciation Party has been rescheduled for this Friday due to last week’s inclement weather.

COUNCIL COMMENTS

- * Discussion on High Street and Highway 100 stop light.
- * Discussion on preparing an ordinance for tents being used for residential purposes.
- * Discussion on the courtesy dock and trash at the Riverfront.
- * Great report given by Community and Economic Development Sal Maniaci during the Chamber of Commerce’s Annual Business Meeting.
- * Despite the weather today, there was a great turnout for Coffee with the Mayor.

CITY ATTORNEY’S REPORT

Public vote on whether or not to hold a closed meeting to discuss personnel, legal and real estate matters pursuant to Section 610.021 RSMo (2000) passed at 7:53 p.m. on the following roll call vote; Holtmeier-aye, Reed-aye, Behr-aye, Patke-aye, Wessels-aye, Coulter-aye, Hidritch-aye, Briggs-absent.

The regular session reconvened at 8:29 p.m.

ADJOURNMENT

With no further business to discuss, a motion to adjourn made at 8:29 p.m. by Councilmember Patke, seconded by Councilmember Wessels passed without dissent.

Adopted: _____

Attest: _____
City Clerk

President of City Council

Passed: _____

Attest: _____
City Clerk

Mayor of Washington, Missouri

**MINUTES OF THE SPECIAL MEETING OF THE CITY COUNCIL
CITY OF WASHINGTON, FRANKLIN COUNTY, MISSOURI
MONDAY, JANUARY 29, 2024**

INTRODUCTORY ITEMS:

The Special Meeting of the City of Washington, Missouri, City Council was held on Monday, January 29, 2024, at 7:00 p.m. in the Council Chamber. Mayor Doug Hagedorn opened the meeting with roll call and Pledge of Allegiance.

| | | | |
|-------------------------|-----------------|---------------|---------|
| Mayor: | | Doug Hagedorn | Present |
| Council Members: | Ward I | Al Behr | Present |
| | | Duane Reed | Present |
| | Ward II | Mark Hidritch | Present |
| | | Mark Wessels | Present |
| | Ward III | Chad Briggs | Present |
| | | Jeff Patke | Present |
| | Ward IV | Mike Coulter | Present |
| | | Joe Holtmeier | Present |

| | | |
|----------------------|--------------------|-------------------|
| Also Present: | City Attorney | Mark Piontek |
| | City Administrator | Darren Lamb |
| | City Clerk | Sherri Klekamp |
| | City Engineer | Charles Stankovic |

Originals and/or copies of agenda items of the meeting, including recorded votes are available on record in the office of the City Clerk. Each ordinance is read a minimum of twice by title, unless otherwise noted.

Approval and Adjustment of Agenda:

A motion to accept and approve the agenda accordingly made by Councilmember Patke, seconded by Councilmember Coulter, passed without dissent.

PRIORITY ITEMS:

Mayor's Presentations, Appointments & Reappointments:

January 23, 2024

City Council

City of Washington

Washington, Missouri

Dear Council Members:

With the resignation of Finance Director Mary Sprung, I herewith submit for your approval the following name for appointment:

Sherri Klekamp – Treasurer/Collector – term ending April 2024

Respectfully submitted,

James D. Hagedorn

Mayor

A motion to accept and approve the appointment made by Councilmember Wessels, seconded by Councilmember Briggs, passed without dissent.

ORDINANCES/RESOLUTIONS

Bill No. 24-12943, Ordinance No. 24-13911, an ordinance authorizing and directing the execution of a Construction Access Agreement by and between the City of Washington, Missouri and Spire Missouri, Inc.

The ordinance was introduced by Councilmember Patke.

After a brief discussion, the ordinance was read a second time and approved on the following vote; Briggs-aye, Reed-aye, Patke-aye, Wessels-aye, Behr-aye, Hidritch-aye, Holtmeier-aye, Coulter-aye.

Bill No. 24-12944, Ordinance No. 24-13912, an ordinance authorizing and directing the execution of a Construction Access Agreement by and between the City of Washington, Missouri and Spire Missouri, Inc.

The ordinance was introduced by Councilmember Behr.

After a brief discussion, the ordinance was read a second time and approved on the following vote; Briggs-aye, Reed-aye, Patke-aye, Wessels-aye, Behr-aye, Hidritch-aye, Holtmeier-aye, Coulter-aye.

Bill No. 24-12945, Ordinance No. 24-13913, an ordinance authorizing and directing the Issuance of a Notice of Award to K.J.U., Inc. D/B/A K.J. Unnerstall Construction Co. for Oldenburg Industrial park Improvements.

The ordinance was introduced by Councilmember Patke.

After a brief discussion, the ordinance was read a second time and approved on the following vote; Briggs-aye, Reed-aye, Patke-aye, Wessels-aye, Behr-aye, Hidritch-aye, Holtmeier-aye, Coulter-aye.

ADJOURNMENT

With no further business to discuss, a motion to adjourn made at 5:12 p.m. by Councilmember Patke, seconded by Councilmember Coulter passed without dissent.

Adopted: _____

Attest: _____
City Clerk

President of City Council

Passed: _____

Attest: _____
City Clerk

Mayor of Washington, Missouri



January 29, 2024

Re: Liquor License

Sherri Klekamp, City Clerk
City of Washington
405 Jefferson St Washington, MO 63090

Dear Sherri,

Joey Conley of underGrounds Coffee LLC , located at 330 W Front St. is applying for a City of Washington liquor license. Mr. Joey Conley has submitted an alcohol license application for the privilege of selling liquor of all kinds by the drink at retail from Monday through Saturday, as well as Sunday. The \$208.35 fees have been paid, and the required paperwork has been submitted. Mr. Joey Conley requested that his application go before the City Council at the February 5th meeting.

Sincerely,

A handwritten signature in blue ink that reads "Heather M. Parker".

Heather Parker
Accounts Specialist I
City of Washington

City of Washington, Missouri
Department of Planning and Engineering Services/Building Code Enforcement
2023 Permit Report

The City of Washington issued 1103 permits in 2023 with a valuation of \$83,639,649.

The permits were broken down as follows:

| PERMIT TYPE | TOTAL PERMITS | VALUATION |
|------------------------------------|---------------|--------------|
| Single Family Building | 55 | \$21,291,276 |
| Single Family Building Attached | 0 | |
| Two-Family Building | 0 | |
| Multi-Family Building | 3 | \$8,761,916 |
| Mobile Home Setup | 5 | |
| Residential Addition | 3 | \$406,000 |
| Residential Alteration | 44 | \$1,510,011 |
| Commercial Building | 4 | \$3,361,526 |
| Commercial Addition | 2 | \$638,465 |
| Commercial Alteration | 37 | \$7,497,911 |
| Industrial Building | 2 | \$27,200,000 |
| Industrial Addition | 1 | \$5,000,000 |
| Industrial Alteration | 3 | \$5,779,000 |
| Accessory Building | 11 | \$206,061 |
| Retaining Wall | 4 | \$112,000 |
| Deck/Porch | 28 | \$374,960 |
| Swimming Pool | 4 | \$163,000 |
| Fire Protection | 7 | \$194,653 |
| Electrical | 57 | \$208,770 |
| Solar Panels | 6 | \$234,001 |
| Sewer Lateral/Repair | 25 | \$28,000 |
| Street Excavation | 128 | |
| Grading | 11 | |
| Demolition (interior and exterior) | 15 | \$171,000 |
| Blasting | 2 | |
| Fair | 1 | |
| Fireworks | 2 | |
| Street Closure | 10 | |
| Antenna/Cell Tower | 2 | \$25,000 |
| Sign/Awning | 56 | \$476,099 |
| Floodplain Development | 8 | |
| Subdivision Development | 1 | |
| Preliminary Plat | 1 | |
| Boundary Adjustment | 5 | |
| Rezoning | 1 | |
| Special Use | 5 | |
| Variance | 0 | |
| Voluntary Annexation | 2 | |
| Historic Design Review | 11 | |
| Residential Occupancy | 517 | |
| Commercial Occupancy | 24 | |
| Industrial Occupancy | 0 | |
| Permit Totals | 1103 | \$83,639,649 |

66

2023 General Construction Permits by Type

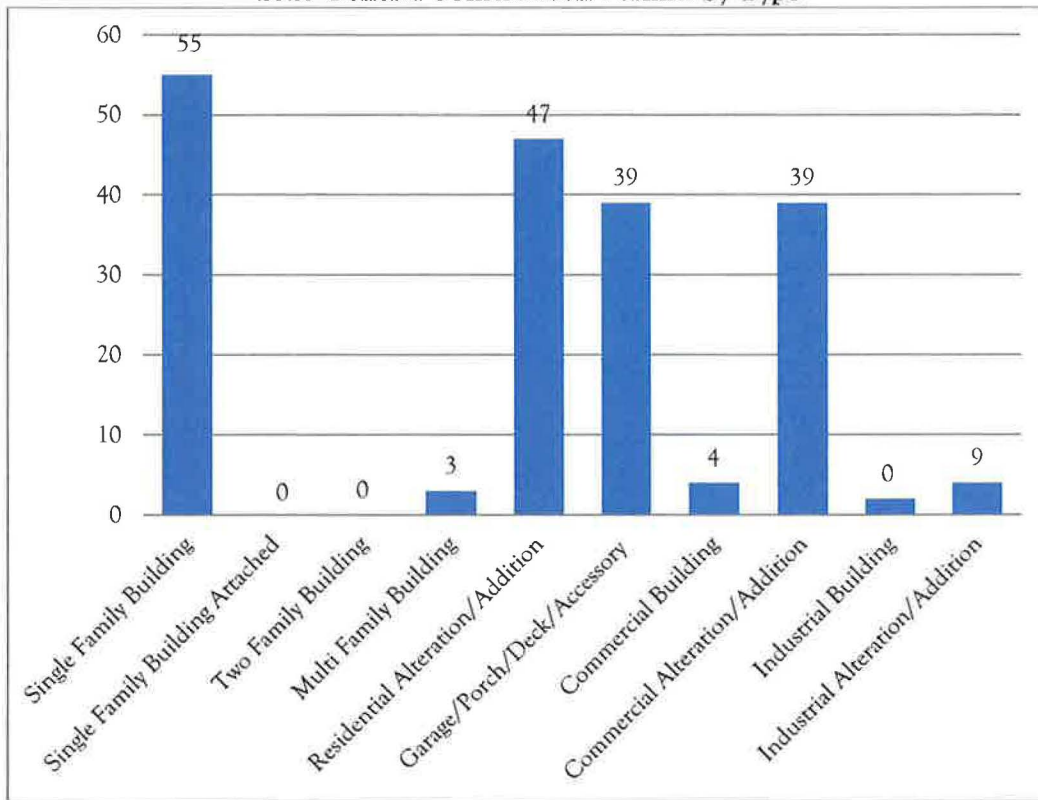

2013 - 2023 New Dwelling Units by Construction Type

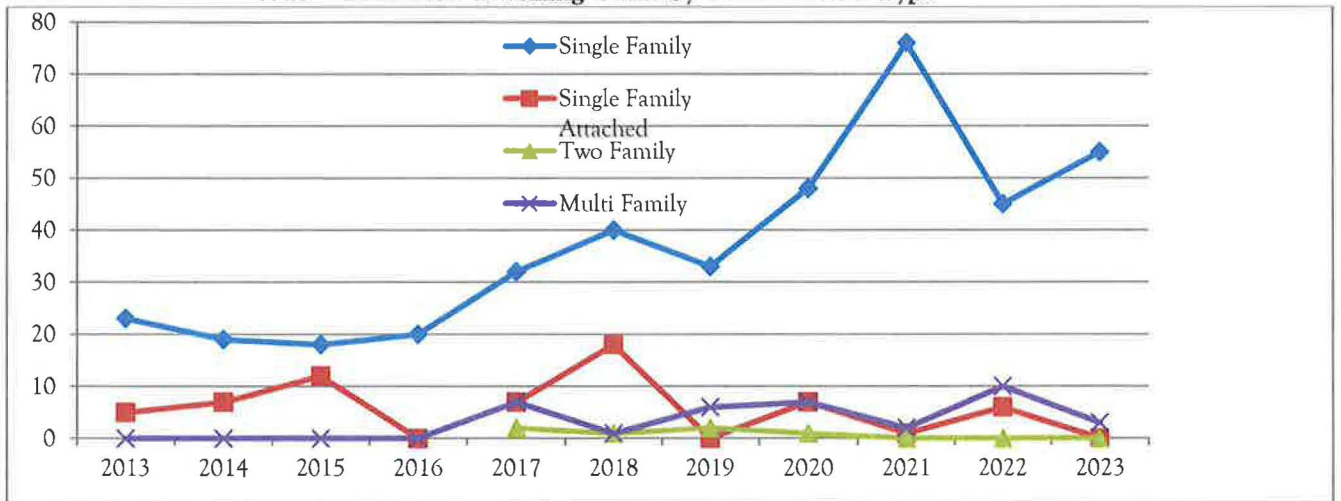

The Residential Occupancy Inspection Program began on April 1, 2007. Residential occupancy inspections were up from 473 in 2022 to 517 in 2023. Commercial occupancy inspections were down from 30 in 2022 to 24 in 2023. The number of Industrial inspections remained the same with 0 for both 2022 and 2023.

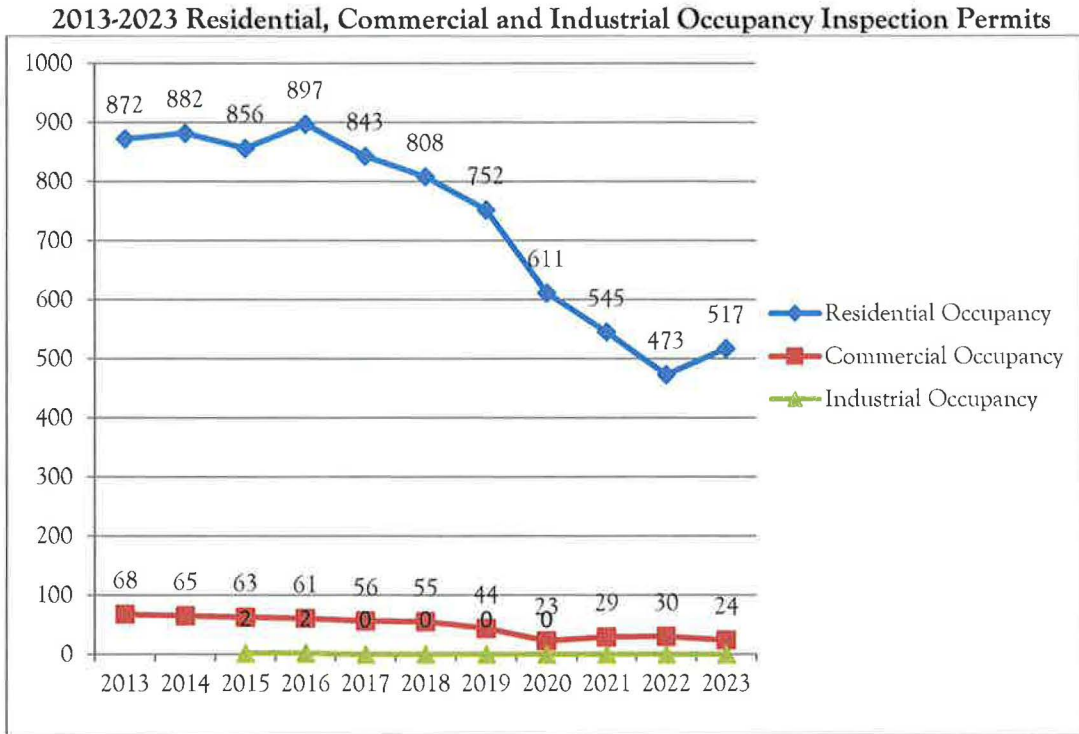

Permit totals for general construction were down from 209 in 2022 to 193 in 2023. This number includes general construction only.

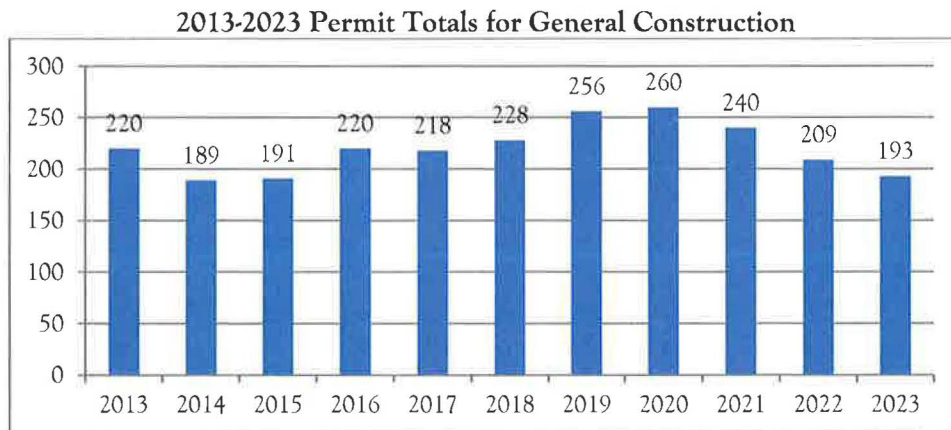

**2013-2023 General Construction Dollars in Millions
(Residential/Commercial/Industrial)**



**2013-2023 Commercial Construction Dollars in Millions
(New/Additions/Alterations)**



bb

2013-2023 Industrial Construction (New Only)
in millions

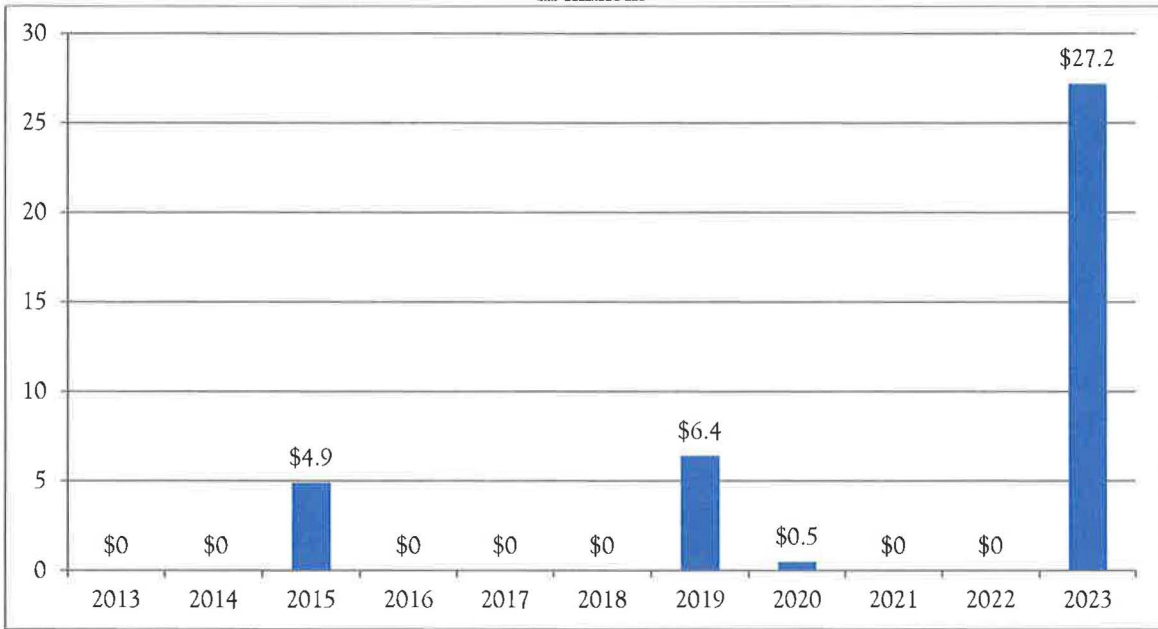

2013-2023 Industrial Construction (Additions/Alterations Only)
in millions

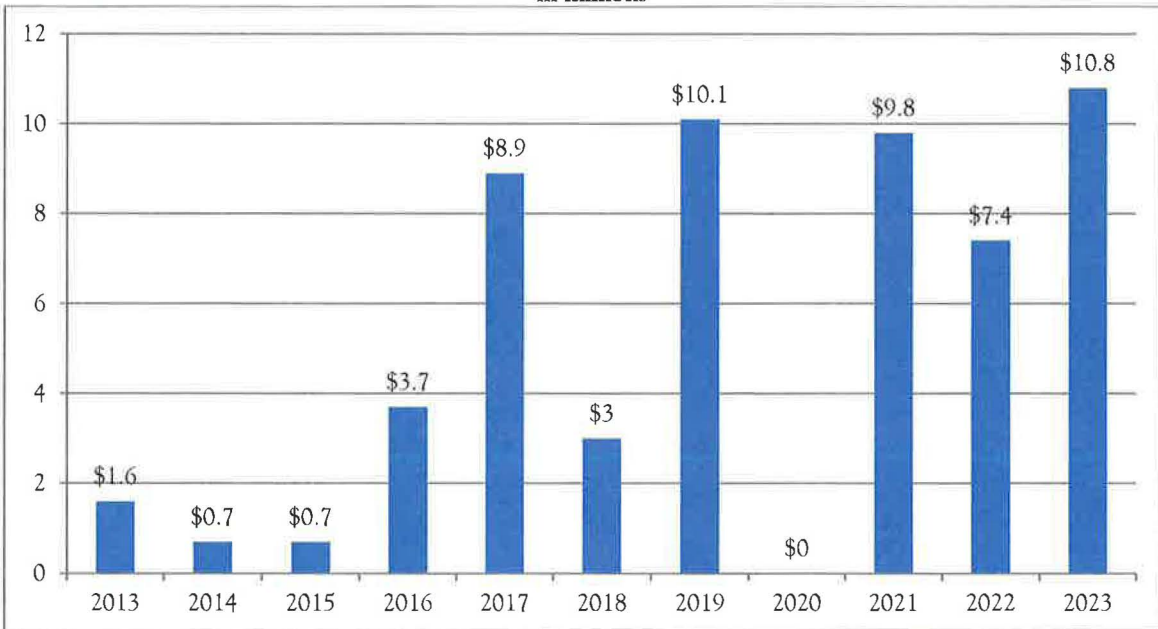

66

New commercial/industrial construction (including additions and alterations) in 2023 included:

| | |
|--|-------------|
| 14 W. Main St. – office remodel | \$25,000 |
| 8 W. 2 nd St. – interior finish | \$75,000 |
| 811 E. 8 th St. – interior finish for Schoeder Insurance | \$150,000 |
| 6224 HWY 100, Ste. 100/140/150/160 – tenant finish | \$90,000 |
| 1190 Jefferson St. – tenant finish for Cornerstone Financial Consultants | \$111,000 |
| 1910 E. 5 th St. – remove 2 exterior windows/replace with doors | \$4,408 |
| 4255 HWY 47 – storage units | \$1,209,000 |
| 1 Pauwels Dr. (WEG) – new mezzanine in maintenance dept | \$86,000 |
| 705 E. 5 th St. – convert building into a sno-cone shop | \$35,000 |
| 1301 W. 5 th St. – interior remodel | \$100,000 |
| 6349 Avantha Dr. – new room for welding | \$193,000 |
| 430 E. 5 th St. – interior remodel for Hearth & Home | \$200,000 |
| 900 Don Ave. – retail strip center | \$990,000 |
| 901 E. 5 th St. – mechanical room updates at Mercy | \$26,100 |
| 1935 Vernaci Dr. – expand Dollar Tree into existing space | \$120,000 |
| 2300 Southbend Dr. – concession stand | \$743,000 |
| 1165 Clock Tower Plaza – office remodel | \$8,000 |
| 550 E. 14 th St. – tenant finish for Compass Health | \$1,272,000 |
| 101 & 103 Elm St. – interior remodel | \$10,000 |
| 901 E. 1 st St. – addition and remodel due to fire | \$450,000 |
| 200 W. Main St. – interior remodel at Bank of Washington | \$1,200,000 |
| 127 Elm St. – rewire existing exterior circuit and add can lights | \$500 |
| 1627 A Roy Dr. – alteration to VA office | \$130,000 |
| 525 Vossbrink Dr. – Texwrap building expansion | \$5,000,000 |
| 3 Chamber Dr. – rooftop solar panels | \$56,430 |
| 300 W. Front St. – canopy enclosure at The Landing | \$40,449 |
| 3016 Phoenix Center – interior buildout | \$94,504 |
| 1935 Vernaci Dr. – interior demo at dollar tree | \$90,000 |
| 6431 Michels Dr. – warehouse building for BK Development | \$1,200,000 |
| 921 W. 14 th St. – addition to Washington Animal Medical Center | \$188,465 |
| 2008 Phoenix Center Dr. – tenant finish | \$30,000 |
| 900 Don Ave. Unit 102 – tenant finish for arcade | \$5,000 |
| 1050 Washington Sq. – tenant finish for Salon Centrix | \$48,000 |
| 1121 Columbus Ln. – repairs to K of C Hall | \$55,000 |
| 205 Jefferson St. – addition of walls and doorway | \$5,000 |
| 1966 Charlotte’s Way – cosmetic improvements to Marshall’s | \$200,000 |
| 903 Don Ave. – new building for Dunkin’ | \$419,526 |
| 24 W. 2 nd St. – tenant finish for Trashy Roots Salon | \$20,000 |

| | |
|---|-------------|
| 2132 HWY A – tenant finish for Life River | \$600,000 |
| 205 Jefferson – tenant finish for Euphoria Rage Room | \$7,000 |
| 3801 Phoenix Center Dr. – tenant finish for Chase Bank | \$900,000 |
| 1481 Marbach Dr. – modification of existing fire sprinkler system | \$20,050 |
| 1900 Washington Crossing – US Bank interior remodel | \$84,000 |
| 3001 Recreation Dr. – rooftop solar panels | \$51,000 |
| 901 Watermann Dr. – install process equipment foundation | \$5,500,000 |
| 1901 Heritage Hills Dr. – remodel for The Sage Bee Prep Academy | \$250,000 |
| 506-D Terry Ln. – repairs due to fire | \$50,000 |
| 2800 Rabbit Trail Dr. – roof over patio at Victorian Place | \$35,000 |



POLICE
CITY OF WASHINGTON

Washington Police Department
Chief Jim Armstrong DSN 256

301 Jefferson Street
Washington, MO 63090
Police Dispatch: 636 390-1050
Direct Line: 636 390-1207
Fax: 636 390-2455

January 23, 2024

Mayor Doug Hagedorn
Washington City Council

RE: Missouri DOT, Traffic Safety Grants for 2024/2025 Budget Year

Honorable Mayor and City Council,

Attached is a memo from Sergeant Mike Grissom. It contains the preliminary highway safety grant applications for 2024/2025 budget year. The usual Hazardous Moving, DWI Enforcement Grant and Youth Alcohol Grant applications are being applied for. All are 100% funded by highway safety funds.

In addition to the manpower grants, the Washington Police Department is requesting funding to send personnel to two different training conferences. An application is being made for funding to send all three of the Department's active Drug Recognition Experts (DRE) to the annual DWI/DRE Conference. We have also applied for funding to send two officers to the Traffic Safety Conference (LETSAC). The cost of the conference registration and room and board is included in the application. The training is 100% funded by the grant.

Below is the breakdown of those grants:

| | |
|--|----------------------|
| Hazardous Moving Violation Enforcement | \$8,000 for manpower |
| LETSAC Conference | \$2,000 for training |
| High visibility raincoats | \$3,100 for safety |
| DWI Enforcement | \$3,000 for manpower |
| DWI/DRE Conference | \$1,800 for training |
| Youth Alcohol Enforcement | \$5,000 for manpower |
| TOTAL | \$22,900.00 |

Also included with Officer Grissom's paperwork is an authorization form, which must be signed by each Council member and the mayor to apply for the grants and prior to receiving any grant funding. I request approval to apply for all the safety grants listed.

Respectfully,

Chief James Armstrong

Jim Armstrong, Chief of Police



POLICE
CITY OF WASHINGTON

Washington Police Department

301 Jefferson Street
Washington, MO 63090
Administration: (636)390-1055
Dispatch: (636)390-1050
Fax: (636)390-2455

January 17, 2024

Chief Armstrong

Attached are the preliminary Highway Safety Grant applications for the 2024/2025 budget year. You will see that I have completed the normal Hazardous Moving, DWI, and Youth Alcohol applications for manpower which are all 100% covered by highway safety funds. Below is a breakdown of the funding requested through those grants.

Hazardous Moving Violation Enforcement

\$8,000 for manpower
\$2,000 for LETSAC Conference
\$3,100 For new high visibility rain coats

DWI Enforcement Grant

\$3,000 for manpower
\$1,800 for DWI/DRE Conference

Youth Alcohol Grant

\$5,000 for manpower

In addition to the manpower grants, I have requested funding to send personnel to two different training conferences. I have applied for funding to send all three of our active DRE's to the DWI/DRE conference and have also applied for funding to send two officers to the LETSAC Conference. The cost for conference registration and room and board is included in the application. In addition to training funds, I have also requested funds to purchase new high visibility rain gear for our patrol officers. If approved, the training and equipment would also be 100% funded by highway safety funds. This leaves our total amount requested at \$22,900.

I have attached a city council authorization form, which must be signed prior to receiving any grant funding for the above mentioned budget year.

Respectfully,

A handwritten signature in black ink, appearing to read "Mike Grissom".

Sgt. Mike Grissom #299

bc



Highway Safety and Traffic Division
P.O. Box 270
Jefferson City, MO 65102
1-800-800-2358 or 573-751-4161

CITY COUNCIL AUTHORIZATION

On _____, 20__ the Council of _____
_____ held a meeting and discussed the City's participation
in Missouri's Highway Safety Program.

It is agreed by the Council that the City of _____
will participate in Missouri's Highway Safety Program.

It is further agreed by the Council that the Chief of Police will investigate the
financial assistance available under the Missouri Highway Safety Program for
Traffic Enforcement and report back to the Council his/her recommendations.
When funding through the Highway Safety Division is no longer available, the
local government entity agrees to make a dedicated attempt to continue support
for this traffic safety effort.

Council Member

Council Member

Council Member

Council Member

Council Member

Council Member

Council Member

Council Member

Mayor

bc

BILL NO. _____ INTRODUCED BY _____

ORDINANCE NO. _____

AN ORDINANCE ACCEPTING THE PROPOSAL FROM BFA
FOR PROFESSIONAL SERVICES FOR THE BUSCH CREEK
GUARDRAIL AND CHANNEL PROTECTION PROJECT

Be It Ordained by the Council of the City of Washington, Missouri, as follows:

SECTION 1: The Mayor is hereby authorized and directed to accept the Proposal from BFA for Professional Services for the Busch Creek Guardrail and Channel Protection Project. A copy of the proposal is attached and is marked as Exhibit A.

SECTION 2: The Mayor and City Clerk are hereby authorized and directed to execute said contract, and to do all things necessary by the terms of said contract.

SECTION 3: All ordinances or parts of ordinances in conflict herewith are hereby repealed.

SECTION 4: This ordinance shall take effect and be in full force from and after its passage and approval.

Passed: _____

ATTEST: _____

Approved: _____

ATTEST: _____

President of City Council

Mayor of Washington, Missouri

103 Elm Street
Washington, MO 63090



636.239.4751
www.bfaeng.com

January 25, 2024

Mr. Charles Stankovic
Infrastructure Designer Engineering Department
405 Jefferson Street
Washington, MO 63090
cstankovic@washmo.gov

RE: Proposal for Professional Services – Busch Creek Guardrail & Channel Protection
BFA #8163

Mr. Stankovic,

BFA, Inc. (BFA) is submitting this proposal to provide Professional Engineering and Surveying Services for the above-referenced project. The proposed 0.50-mile guardrail and channel protection are anticipated to be constructed in one (1) phase. See Exhibit A for Project Area. The anticipated improvements include the following:

- Guardrail along W. Eight Street from Elm Street to Locust Street
- Channel protection along Busch Creek to help with erosion, washout, city maintenance, and aesthetics.

Per the Request for Qualifications, the approximate construction cost is \$300,000. BFA's general scope of work is to prepare plans and bid documents for the project. For this scope of work, **BFA's Estimated Fee is \$82,000**. Below is a brief description of our proposed scope of work with associated fees.

Kickoff Meeting and Due Diligence

Estimated Fee: \$4,500

- Kickoff Meeting with City
- Develop scope of work
- Contact the Corps of Engineers and review documents

Survey Services

Estimated Fee: \$20,500

Upon project award, BFA will contact Missouri One Call for a Public Utility Locate; however, we ask that the City also mark any private utilities they are aware of in the project area, such as laterals and lighting electrical lines. Once the utilities have been marked, BFA will gather field data of the existing site features. Anticipated tasks to be completed are as follows:

- Public Utility Locate
- Site Survey of Existing Conditions
- Draw the gathered topographic data in AutoCAD
- Drawing to include the location of utilities per the utility locate. This does not include coordination with the utility companies to verify the location.

BFA's survey services do not include locating property corners, establishing City right-of-way, or a boundary survey. We can provide a separate proposal or perform these services on a time and material basis if requested.

Locate Right-of-Way based on Existing Surveys

Estimate Fee: \$1000

- Review available plats and deeds
- Fieldwork to locate a few property corners along the right-of-way on each side of the road to tie into the available GIS maps (survey monuments, iron rods, etc.)
- Add right-of-way information to the topographic survey
- This does not include an exhibit
- This does not include meet and bounds description

This could range from **\$1,000 to \$10,000**, depending on the quality of available plats.

Concept Plans and Construction Cost Estimates

Estimated Fee: \$10,800

Once BFA has the field data, we will begin identifying the scope of work for the creek stabilization options and areas that need repair. The proposed Concept Plans will then be shared and discussed with City Staff for review and comment. BFA will prepare a preliminary Cost Estimate of the proposed improvements. Anticipated tasks are as follows:

- Prepare three Concept Plan options
- Prepare associated Construction Cost Estimates
- Meeting with City Staff to discuss the existing conditions and preliminary scope of work options
- Revise Preliminary Scope of Work options based on City comments (1 set of comments included, not to exceed \$3,000)
- This does not include public meetings or exhibits

Preparation of Preliminary Design Improvement Plans

Estimated Fee: \$12,500

Once BFA has met with the City to discuss the existing conditions and scope of work options, we will begin developing preliminary design plans for the proposed improvements. Preliminary plans will be prepared for a city meeting where comments from the city will be taken. After the meeting, BFA will revise the plans and meet with the city again to review the revisions. The final plan stage will address minor comments from the second meeting. Anticipated tasks are as follows:

- Develop Preliminary Improvement Plans. Anticipated plan sheets include a Cover Sheet, Topographic Survey, Demolition Plan, Site Plan, Utility Plan, and Grading Plan.
- Meeting with City Staff to discuss preliminary plans (2 meetings included)
- Revise Preliminary Improvement Plans based on city comments (not to exceed **\$1,200**)

Permits and Regulatory Requirements – Floodplain

Estimated Fee: \$6,000

To satisfy the regulatory requirements for maintenance in the floodway, BFA will perform comparison calculations of the existing cross-section conditions to the proposed conditions. This analysis will be used to determine if the proposed improvements result in a “No—Rise.” Anticipated tasks are as follows:

- Prepare a No-Rise Analysis/Certification with supporting comparison calculations
- Prepare a Floodplain Development Permit Application
- This does not include detailed river analysis calculations (HEC RAS)

Permits and Regulatory Requirements – US Army Corps of Engineering (USACE)

Estimated Fee: \$12,200

BFA will prepare a cross-section and plan exhibit for the USACE to satisfy the regulatory requirements for maintenance in a jurisdiction stream. This assumes that stream stabilization will result in no loss in allowable stream flow. Anticipated tasks are as follows:

- Prepare an application for a national wide permit
- Prepare a stream cross-section exhibit with existing and proposed features
- Prepare a plan view Exhibit on an aerial
- Correspondence with the Army Corps of Engineers
- This does not include a 404 Individual permit or mitigation plan
- This does not include permitting fees

Preparation of Final Plans

Estimated Fee: \$14,500

Final Plans, Specifications, and Details Sheets will be prepared for bidding purposes, along with a Cost Estimate of the Final Site Improvements. The Final Plans and Documents will be provided to the City in .pdf format and one full-size hard copy. Anticipated tasks are as follows:

- Develop Final Signed and Sealed Improvement Plans and Details
- Prepare a Final Cost Estimate of Improvement Plans
- Prepare Specifications
- Address the second set of minor comments on preliminary plans, if applicable (not to exceed \$1,200)
- Provide PDF and hard copy of final signed documents

BFA’s anticipated schedule for this project would be to perform the site topographic survey and concept plans and then schedule a meeting with the City. The Preliminary Design Plans would follow the initial meeting. Once Final Plans are completed, BFA will provide the City with one hard copy and PFD. For scheduling purposes, BFA should be able to commence the site topographic survey within six (6) to eight (8) weeks of receiving authorization. Anticipated construction is to start in June 2025.

BFA’s proposed fee does not include the following services and items. Should the City wish for any of the below items to be included, we can provide these services and negotiate the associated fee(s):

- Permitting fees, such as MDNR, USACE, and FEMA, should they be required
- Geotechnical Services
- Environmental and Historic Preservation Services/Permits
- Right-of-way acquisition assistance and/or boundary determination
- Locate property corners to establish City Right-of-way
- Preparation of temporary construction easements and permanent easements
- Retaining Wall and Bridge/Culvert design
- This proposal includes addressing two (2) sets of City comments with plan modifications. Should major plan revisions be requested by the City after preparation of the Preliminary Design Improvements, additional fees may be incurred.
- This proposal includes four (4) City meetings. Should additional meetings be requested, additional fees may be incurred (Estimated Fee \$1000/meeting)
- Additional hard copies of the plan set (estimate includes one (1) set)

- Files such as AutoCAD, LandXML, etc. (includes one PFD and one hard copy of final signed documents)
- Coordination with utility companies to verify the location of telecommunication, water, sewer, stormwater, electric, and gas.
- Coordination with utility companies to relocate utilities.
- DNR Land Disturbance Permit, ESC plans, and SWPPP specifications
- Grant Assistance – The city is going to coordinate with Franklin County
- Design for construction project over \$300,000 per the City’s Construction estimate. Preparation of preliminary and final plans is based on the construction estimate at 9% in design fees.

The City of Washington will be billed monthly on a time and materials basis. **Rates are subject to change annually. Should a rate increase occur during the duration of the project, a revised estimate will be provided to the City.** Reimbursable printing, mileage, permit fees, etc., will be billed at cost to BFA without any markup and are not included in our proposed Engineering and Surveying Fee proposal. BFA shall obtain written approval from the City before performing any work outside the project's scope.

Please provide formal authorization for us to begin work on this project by signing below and returning this document to us. BFA’s proposal and fees for this project shall remain applicable for 60 days after execution by BFA below.

We are excited about the opportunity to work with the City on this project. Please feel free to contact us at any time should you have questions about our services and this proposal.

Best regards,

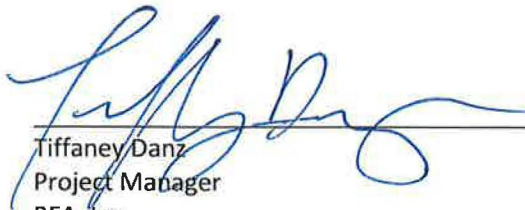

Tiffany Danz
Project Manager
BFA, Inc.
Direct: 636.231.4319
tdanz@bfaeng.com

1/25/24
Date

CLIENT ACCEPTANCE OF PROPOSAL FOR PROFESSIONAL SERVICES

BFA Inc. Authorization:

Client Authorization:



Raymond H. Frankenberg II
President

Name:
Title:

1-25-24
Date

Date



January 31, 2024

Honorable Mayor and City Council
City of Washington
Washington, MO 63090

RE: Busch Creek Guardrail and Channel Protection Project

Dear Mayor and City Council Members:

Find enclosed an ordinance that would allow the City to enter into a contract with BFA for engineering services for the Busch Creek Guardrail and Channel Protection Project. This project includes new guardrail installation and creek bank stabilization and protection along Busch Creek at Eighth Street from Elm Street to Locust Street.

The contract proposes the following compensation amounts:

DESIGN costs \$82,000.00

Construction is anticipated to start in June of 2025. There is a Franklin County Transportation Grant of \$50,000 for the construction of the guardrail on this project. This contract is budgeted through the Stormwater Fund. Approval is recommended.

Sincerely,

Charles Stankovic, P.E.
Interim City Engineer

BILL NO. _____ INTRODUCED BY _____

ORDINANCE NO. _____

AN ORDINANCE AUTHORIZING AND DIRECTING THE EXECUTION OF A STANDARD FORM OF AGREEMENT BY AND BETWEEN THE CITY OF WASHINGTON, MISSOURI AND FGM ARCHITECTS, INC & AMEND THE 2023/2024 BUDGET

BE IT ORDAINED by the Council of the City of Washington, Missouri, as follows:

SECTION 1: The Mayor is hereby authorized and directed to execute a Standard Form of Agreement by and between the City of Washington, Missouri and FGM Architects, Inc., a copy of which is marked Exhibit I and is attached hereto and incorporated herein by reference, and such other documents, certificates and instruments as may be necessary or desirable to carry out and comply with the intent of this Ordinance, for and on behalf of and as the act and deed of the City. The City Clerk is hereby authorized and directed to attest to and affix the seal of the City to the said Agreement and such other documents, certificates and instruments as may be necessary or desirable to carry out and comply with the intent of this Ordinance.

SECTION 2: The City shall, and the officials, agents and employees of the City are hereby authorized and directed to, take such further action, and execute and deliver such other documents, certificates and instruments as may be necessary or desirable to carry out and comply with the intent of this Ordinance.

SECTION 3: The ordinance shall amend the 2023/2024 Budget as follows:

Fire Department Reserve Fund - Decrease of \$500,000 for fire station design, site evaluation and construction management (004-341000).

Building Fund – Increase of \$500,000 for fire station design, site evaluation and construction management (260-24-000-540200).

SECTION 4: All ordinances or parts of ordinances in conflict herewith are hereby repealed.

SECTION 5: This ordinance shall be in full force and effect from and after its passage and approval.

Passed: _____

ATTEST: _____

President of City Council

Approved: _____

ATTEST: _____

Mayor of Washington, Missouri

DRAFT AIA® Document B101™ - 2017

Standard Form of Agreement Between Owner and Architect

AGREEMENT made as of the «Twenty-Sixth » day of «January » in the year «Two Thousand Twenty-Four »

(In words, indicate day, month and year.)

BETWEEN the Architect's client identified as the Owner:
(Name, legal status, address and other information)

«City of Washington, Missouri»
«405 Jefferson Street
Washington, Missouri 63090»
«Telephone Number: 636.390.1010»

and the Architect:
(Name, legal status, address and other information)

«FGM Architects Inc.»
«One Metropolitan Square, Suite 1945
St. Louis, Missouri 63102»
«Telephone Number: 314.459.1601»
«Fax Number: 314.459.1602»

for the following Project:
(Name, location and detailed description)
City of Washington, Missouri / Washington Fire Department:
New Satellite Fire Facility

The Owner and Architect agree as follows:

This Agreement shall serve as a Master Agreement establishing the terms of service for the Project assigned by the Owner to the Architect. Owner and Architect have developed this Agreement which establishes specific parameters for the Project assigned by the Owner to the Architect.

ADDITIONS AND DELETIONS:

The author of this document has added information needed for its completion. The author may also have revised the text of the original AIA standard form. An *Additions and Deletions Report* that notes added information as well as revisions to the standard form text is available from the author and should be reviewed.

This document has important legal consequences. Consultation with an attorney is encouraged with respect to its completion or modification.



ELECTRONIC COPYING of any portion of this AIA® Document to another electronic file is prohibited and constitutes a violation of copyright laws as set forth in the footer of this document.

76

TABLE OF ARTICLES

| | |
|----|--------------------------------------|
| 1 | INITIAL INFORMATION |
| 2 | ARCHITECT'S RESPONSIBILITIES |
| 3 | SCOPE OF ARCHITECT'S BASIC SERVICES |
| 4 | SUPPLEMENTAL AND ADDITIONAL SERVICES |
| 5 | OWNER'S RESPONSIBILITIES |
| 6 | COST OF THE WORK |
| 7 | COPYRIGHTS AND LICENSES |
| 8 | CLAIMS AND DISPUTES |
| 9 | TERMINATION OR SUSPENSION |
| 10 | MISCELLANEOUS PROVISIONS |
| 11 | COMPENSATION |
| 12 | SPECIAL TERMS AND CONDITIONS |
| 13 | SCOPE OF THE AGREEMENT |

ARTICLE 1 INITIAL INFORMATION

§ 1.1 This Agreement is based on the Initial Information set forth in this Section 1.1. and Exhibit B, the Preliminary Design Memorandum for the Project. To the extent of any inconsistency, conflict or discrepancy between the Master Agreement and an indicated exhibit, the Master Agreement shall control. "Project" as used herein shall mean the work authorized by this Agreement. *(For each item in this section, insert the information or a statement such as "not applicable" or "unknown at time of execution.")*

§ 1.1.1 The Owner's program for the Project: *(Insert the Owner's program, identify documentation that establishes the Owner's program, or state the manner in which the program will be developed.)*

« Attached Exhibit B, Preliminary Design Memorandum shall incorporate the following Initial Information:

1. The Owner's program for the Project.
2. The Project's preliminary space plan and site location.

§ 1.1.2 The Project's physical characteristics: *(Identify or describe pertinent information about the Project's physical characteristics, such as size; location; dimensions; geotechnical reports; site boundaries; topographic surveys; traffic and utility studies; availability of public and private utilities and services; legal description of the site, etc.)*

«To be determined during a program verification phase of service.

Preliminarily, the Owner intends to have planned, designed and constructed a new satellite fire facility at the intersection of Vernaci Drive at Earth Crest Drive (near the entrance to Stone Crest Subdivision and Phoenix Park) in Washington, Missouri. Size of the facility is anticipated to range between 9,000-12,000 gross square feet and would feature multiple drive-through apparatus bays, living quarters and support spaces. The Project would also affect site development as required. Site survey, utilities verification(s) and subsurface drilling data, as well as Geotechnical Engineering recommendations and any environmental assessments therefrom – are yet to be gathered.

§ 1.1.3 The Owner's budget for the Cost of the Work, as defined in Section 6.1: *(Provide total and, if known, a line item breakdown.)*

The Owner's budgeted Total Project Cost is anticipated to be between \$4.5 and 5.2MM, and would include Cost of the Work and Indirect Construction Cost, including, but not limited to administrative costs, professional fees, site investigation and land surveying, testing / observation / special inspections, furniture and equipment, and miscellaneous construction contingencies as endorsed by the Owner and required to realize the project.

§ 1.1.4 The Owner's anticipated design and construction milestone dates:

- .1 Design phase milestone dates, if any:
«Preliminary / projected design phase dates would target a program phase completion by March 2024, a design completion in April 2024, a bidding documents completion and solicitation for construction bids in August 2024 and a competitive bidding construction contract letting in September 2024. »
- .2 Construction commencement date: «TBV. Preliminary / projected implementation phase dates would target a site mobilization / construction start of October 2024. »
- .3 Substantial Completion date or dates: «TBV. Preliminary / projected implementation phase dates would target a Substantial Completion date in November of 2025. »
- .4 Other milestone dates:
«To be determined »

§ 1.1.5 The Owner intends the following procurement and delivery method for the Project: *(Identify method such as competitive bid or negotiated contract, as well as any requirements for accelerated or fast-track design and construction, multiple bid packages, or phased construction.)*

«Competitive Bid. »

§ 1.1.6 The Owner's anticipated Sustainable Objective for the Project: *(Identify and describe the Owner's Sustainable Objective for the Project, if any.)*

«Not Applicable. »

§ 1.1.6.1 If the Owner identifies a Sustainable Objective, the Owner and Architect shall complete and incorporate a Sustainable Projects Exhibit into this Agreement to define the terms, conditions and services related to the Owner's Sustainable Objective. If such an exhibit is incorporated into this agreement, the Owner and Architect shall incorporate the completed exhibit into the agreements with the consultants and contractors performing services or Work in any way associated with the Sustainable Objective, and shall adjust the compensation and design and construction milestone dates as required.

§ 1.1.7 The Owner identifies the following representative in accordance with Section 5.3: *(List name, address, and other contact information.)*

«Mr. Tim Frankenberg, CSP, CT, CFPS – Fire Chief
City of Washington / Washington Fire Department »
«200 East 14th Street »
Washington, Missouri 63090 »
«Telephone Number: 636.390.1020 »
Email: tpfrankenberg@washmo.gov »
«»

§ 1.1.8 The persons or entities, in addition to the Owner's representative, who are required to review the Architect's submittals to the Owner are as follows: *(List name, address, and other contact information.)*

«To be determined. »

§ 1.1.9 If appropriate, the Owner shall retain the following consultants and contractors which shall be incorporated in an amendment to this Agreement:

(List name, legal status, address, and other contact information.)

1. Geotechnical Engineer and sub-Surface Driller
2. Land Surveyor
3. Title Commitments Researcher
4. Environmental Consultant
5. Natural Resource Consultant
6. Historical Archeologist
7. Traffic Consultant
8. Third-Party Cost Consultant (if in complement to FGMA's Supplemental Service)
9. Third-Party Building Code Plan Reviewer
10. Construction Testing Contractor
11. Building Code Site Inspections Inspector
12. Called Inspections Inspector
13. Mechanical and Electrical Commissioning Agent(s) (CxA)

Note that budgetary proposals for certain consulting services anticipated to be required for the project have been collected on behalf of the Owner, and are provided under separate cover for the Owner's convenience and review. Some or all of these services may be Contracted direct to the Owner – refer to matrix and compensation paragraphs below, as well as Exhibit C, Fee Matrix.

§ 1.1.10 The Architect identifies the following representative in accordance with Section 2.3:

(List name, address, and other contact information.)

«Joshua N. Mandell, AIA, NCARB, LEED AP BD+C, Principal-in-Charge
FGM Architects Inc. »

«One Metropolitan Square, Suite 1945 »

«St. Louis, Missouri 63102 »

«Telephone Number: 314.439.1601 »

«Email: joshuamandell@fgmarchitects.com »

§ 1.1.11 If appropriate, the Architect shall retain the consultants identified in Sections 1.1.11.1 and 1.1.11.2:

(List name, legal status, address, and other contact information.)

§ 1.1.11.1 Consultants retained under Supplemental Services and / or Basic Services as required per this Agreement:

- .1 Land Surveyor / Title Commitments Researcher (Supplemental Service, if not to be contracted direct to Owner):

«Thouvenot, Wade and Moerchen, Inc. »«(TWM) »

«400 North 5th Street, Suite 101 »

«St. Charles, Missouri 63301 »

«Telephone: 636.724.8300 »

- .2 Geotechnical Engineer and sub-Surface Driller (Supplemental Service, if not to be contracted direct to Owner):

«Bacon Farmer Workman Engineering & Testing, Inc. »«(BFW) »

«521 West Main Street, Suite 200 »

«Belleville, Illinois 62220 »

«Telephone: 618.771.5774 »

- .3 Environmental Consultant (Supplemental Service, if not to be contracted direct to Owner):

«Bacon Farmer Workman Engineering & Testing, Inc. »«(BFW) »

«521 West Main Street, Suite 200 »

«Belleville, Illinois 62220 »

«Telephone: 618.771.5774 »

- .4 Civil Engineer (Supplemental Service):
 «Bacon Farmer Workman Engineering & Testing, Inc. »«(BFW) »
 «521 West Main Street, Suite 200 »
 «Belleville, Illinois 62220 »
 «Telephone: 618.771.5774 »

- .5 Structural Engineer (Basic Service):
 «Bacon Farmer Workman Engineering & Testing, Inc. »«(BFW) »
 «521 West Main Street, Suite 200 »
 «Belleville, Illinois 62220 »
 «Telephone: 618.771.5774 »

- .6 Mechanical Engineer (Basic Service):
 «Marcum Engineering, LLC »«(Marcum) »
 «521 West Main Street, Suite 200 »
 «Belleville, Illinois 62220 »
 «Telephone: 618.771.5774 »

- .7 Electrical Engineer (Basic Service):
 «Marcum Engineering, LLC »«(Marcum) »
 «521 West Main Street, Suite 200 »
 «Belleville, Illinois 62220 »
 «Telephone: 618.771.5774 »

- .8 Plumbing Engineer (Basic Service):
 «Marcum Engineering, LLC »«(Marcum) »
 «521 West Main Street, Suite 200 »
 «Belleville, Illinois 62220 »
 «Telephone: 618.771.5774 »

- .9 Fire Protection Engineer (Basic Service):
 «Marcum Engineering, LLC »«(Marcum) »
 «521 West Main Street, Suite 200 »
 «Belleville, Illinois 62220 »
 «Telephone: 618.771.5774 »

- .10 Low-Voltage Electrical Systems Designer (Supplemental Service):
 «Marcum Engineering, LLC »«(Marcum) »
 «521 West Main Street, Suite 200 »
 «Belleville, Illinois 62220 »
 «Telephone: 618.771.5774 »

- .11 Landscape Architect (Supplemental Service):
 «Dermody & Associates, LLC »«(Dermody) »
 «2394 Charlemagne Drive »
 «St. Louis, Missouri 63043 »
 «Telephone: 314.602.8542 »

- .12 Interior Design and Design / Procurement Assistance with FFE (Supplemental Service):
 «FGM Architects Inc. »«(FGMA) »
 «One Metropolitan Square, Suite 1945 »
 «St. Louis, Missouri 63102 »
 «Telephone: 314.439.1601 »

- .13 Third-Party Construction Cost Estimator (Supplemental Service, in addition to estimating by FGMA):
 «Middleton Consulting & Contracting »«(Middleton) »



«5600 North River Road, Suite 950 »
«Rosemont, Illinois 60018 »
«Telephone: 312.445.0000 »

§ 1.1.11.2 If appropriate, Consultants retained under Additional Services as potentially listed below shall be incorporated in an amendment to this Agreement:

1. *Reserved*
2. *Reserved*
3. *Reserved*
4. Environmental Consultant
5. Natural Resource Consultant
6. Historical Archaeologist
7. Traffic Consultant
8. Specialized Consultant to review eligibility for certification of sustainable design by US Green Building Council (LEED), Green Globes or similar organizations.
9. Building Code Plan Reviewer and Building Code Site Inspector
10. Third-Party Cost Consultant (if in complement to FGMA's Supplemental Service)
11. Third-Party Building Code Plan Reviewer
12. Acoustical Consultant
13. Construction Testing and Special Inspections Contractor
14. Building Code Site Inspections Inspector
15. Called Inspections Inspector
16. Mechanical and Electrical Commissioning Agent(s) (CxA)

§ 1.1.12 Other Initial Information on which the Agreement is based:

Refer to Exhibit B, Preliminary Design Memorandum.

§ 1.2 The Owner and Architect may rely on the Initial Information. Both parties, however, recognize that the Initial Information may materially change and, in that event, the Owner and the Architect shall appropriately adjust the Architect's services, schedule for the Architect's services, and the Architect's compensation. The Owner shall adjust the Owner's budget for the Cost of the Work and the Owner's anticipated design and construction milestones, as necessary, to accommodate material changes in the Initial Information.

§ 1.3 The parties shall agree upon protocols governing the transmission and use of Instruments of Service or any other information or documentation in digital form.

§ 1.3.1 Any use of, or reliance on, all or a portion of a building information model without agreement to protocols governing the use of, and reliance on, the information contained in the model and without having those protocols set forth in AIA Document E203™–2013, Building Information Modeling and Digital Data Exhibit, and the requisite AIA Document G202™–2013, Project Building Information Modeling Protocol Form, shall be at the using or relying party's sole risk and without liability to the other party and its contractors or consultants, the authors of, or contributors to, the building information model, and each of their agents and employees.

ARTICLE 2 ARCHITECT'S RESPONSIBILITIES

§ 2.1 The Architect shall provide professional services as set forth in this Agreement. The Architect represents that it is properly licensed in the jurisdiction where the Project is located to provide the services required by this Agreement or shall cause such services to be performed by appropriately licensed design professionals.

§ 2.2 The Architect shall perform its services consistent with the professional skill and care ordinarily provided by architects practicing in the same or similar locality under the same or similar circumstances. The Architect shall perform its services as expeditiously as is consistent with such professional skill and care and the orderly progress of the Project.

§ 2.3 The Architect shall identify a representative authorized to act on behalf of the Architect with respect to the Project.

§ 2.4 Except with the Owner's knowledge and consent, the Architect shall not engage in any activity, or accept any employment, interest or contribution that would reasonably appear to compromise the Architect's professional judgment with respect to this Project.

§ 2.5 The Architect shall maintain the following insurance until termination of this Agreement. If any of the requirements set forth below are in addition to the types and limits the Architect normally maintains, the Owner shall pay the Architect as set forth in Section 11.9.

§ 2.5.1 Commercial General Liability with policy limits of not less than «One Million Dollars » (\$ «1,000,000 ») for each occurrence and «Two Million Dollars » (\$ «2,000,000 ») in the aggregate for bodily injury and property damage.

§ 2.5.2 Automobile Liability covering vehicles owned, and non-owned vehicles used, by the Architect with policy limits of not less than «One Million Dollars » (\$ «1,000,000 ») combined single limit and aggregate for for bodily injury, death of any person, and property damage covering non-owned and rented vehicles operated by the Architect.

§ 2.5.3 The Architect may achieve the required limits and coverage for Commercial General Liability and Automobile Liability through a combination of primary and excess or umbrella liability insurance, provided such primary and excess or umbrella liability insurance policies result in the same or greater coverage as the coverages required under Sections 2.5.1 and 2.5.2, and in no event shall any excess or umbrella liability insurance provide narrower coverage than the primary policy. The excess policy shall not require the exhaustion of the underlying limits only through the actual payment by the underlying insurers.

§ 2.5.4 Workers' Compensation at statutory limits.

§ 2.5.5 Employers' Liability with Statutory limits not less than «Five Hundred Thousand Dollars » (\$ «500,000 ») each accident, disease, death.

§ 2.5.6 Professional Liability covering negligent acts, errors and omissions in the performance of professional services with policy limits of not less than «Two Million Dollars » (\$ «2,000,000 ») per claim and «Three Million Dollars » (\$ «3,000,000 ») in the aggregate.

§ 2.5.7 **Additional Insured Obligations.** To the fullest extent permitted by law, the Architect shall cause the primary and excess or umbrella policies for Commercial General Liability and Automobile Liability to include the Owner as an additional insured for claims caused in whole or in part by the Architect's negligent acts or omissions. The additional insured coverage shall be primary and non-contributory to any of the Owner's insurance policies and shall apply to both ongoing and completed operations.

§ 2.5.8 The Architect shall provide certificates of insurance to the Owner that evidence compliance with the requirements in this Section 2.5.

ARTICLE 3 SCOPE OF ARCHITECT'S BASIC SERVICES

§ 3.1 As required by this Agreement, the Architect's Basic and Supplemental Services consist of those described in this Article 3 and as further enumerated in Article 4, and include usual and customary Basic structural, mechanical, and electrical engineering services, as well as Supplemental civil engineering, low-voltage electrical systems design, landscape architecture, interior design and procurement assistance with FFE, and third-party construction cost estimation services. Supplemental services may also include land surveying and title commitments research, geotechnical engineering and sub-surface drilling, and environmental consulting. Services not set forth in this Article 3 are Additional Services.

§ 3.1.1 The Architect shall manage the Architect's services, consult with the Owner, research applicable design criteria, attend Project meetings reasonably requested by the Owner, communicate with members of the Project team, and report progress to the Owner.

§ 3.1.2 The Architect shall coordinate its services with those services provided by the Owner, if applicable, the Construction Manager and the Owner's consultants. The Architect shall be entitled to rely on, and shall not be responsible for, the accuracy, completeness, and timeliness of, services and information furnished by the Owner, if applicable the Construction Manager and the Owner's consultants. The Architect shall provide prompt written notice to the Owner only if the Architect becomes aware of any error, omission, or inconsistency in such services or information, however, the Architect assumes no duty to discover such errors, omissions or inconsistencies.

§ 3.1.3 As soon as practicable after the date of this Agreement, the Architect shall submit for the Owner's approval a schedule for the performance of the Architect's services. The schedule initially shall include anticipated dates for the commencement of construction and for Substantial Completion of the Work as set forth in the Initial Information. The schedule shall include allowances for periods of time required for the Owner's review, for the performance of the Owner's consultants, and a reasonable time for approval of submissions by authorities having jurisdiction over the Project. The Owner shall render decisions in a timely manner so as to not adversely affect the schedule or cause the schedule to be exceeded. Once approved by the Owner, time limits established by the schedule shall not, except for reasonable cause, be exceeded by the Architect or Owner. With the Owner's approval, the Architect shall adjust the schedule, if necessary, as the Project proceeds until the commencement of construction.

§ 3.1.4 The Architect shall not be responsible for an Owner's directive, design change or substitution, or for the Owner's acceptance of non-conforming Work, made or given without the Architect's written approval.

§ 3.1.5 The Architect shall contact governmental authorities required to approve the Construction Documents and entities providing utility services to the Project. The Architect shall use professional care to respond to applicable written publicly available design requirements imposed by those authorities and entities having jurisdiction over the design of the Project. The Architect shall not be responsible for additional costs incurred because of a reasonable difference of opinion or interpretation of applicable code requirements with that of such governmental authorities.

§ 3.1.6 The Architect shall assist the Owner in connection with the Owner's responsibility for filing documents required for the approval of governmental authorities having jurisdiction over the Project.

§ 3.1.7 If the Architect's services involve making changes to an existing facility, the Owner shall furnish documentation, drawings and information on the existing facility upon which the Architect may rely for accuracy and completeness. Unless specifically authorized or confirmed in writing by the Owner, the Architect shall not be required to perform or to cause to be performed any destructive testing or investigation of concealed or unknown conditions. In the event the documentation, drawings or information furnished by the Owner is inaccurate or incomplete, all resulting costs and expenses, including the cost of Additional Services of the Architect, shall be borne by the Owner. To the fullest extent permitted by law, the Owner shall defend, indemnify and hold harmless the Architect and its consultants from and against all claims, liabilities, damages, losses, costs and expenses, including attorney's fees, arising out of or resulting from the drawings, documentation and information furnished by the Owner.

§ 3.1.8 If the Project involves remodeling and/or rehabilitation of an existing structure, certain assumptions regarding existing conditions are required to be made. Since some of these assumptions may not be verifiable within Owner's budget or without destroying otherwise adequate or serviceable portions of the Project, the Owner agrees that, except for specific tasks identified for the Architect to perform under the Agreement, the Owner shall reimburse the Architect as an Additional Service for changes, modifications, additions or alterations to the Construction Documents which may arise or result from unforeseen or concealed conditions. The Owner shall, to the fullest extent permitted by law, defend, indemnify, and hold harmless the Architect and its consultants from and against all claims, damages, liabilities, losses, costs, damages and expenses, including attorney's fees, arising from unforeseen or concealed conditions.

§ 3.1.9 The LEED Green Building Rating System and other similar environmental guidelines (collectively referred to as "LEED Guidelines") utilize certain design and usability recommendations for a project in order to promote an environmentally friendly and energy efficient facility. When LEED Guidelines are required by the Owner to be used for the Project, the Architect shall use professional care to interpret and apply the LEED Guidelines to the Project. The Owner acknowledges and understands that LEED Guidelines are subject to various and possibly contradictory

interpretations and that compliance may involve factors beyond the control of the Architect, including such factors as Owner's use and operation of the completed Project. The Architect does not warrant or represent that the Project will achieve LEED certification or that the estimates of energy savings and costs relating to building or equipment operation will actually be realized by the Owner. The Architect shall not be responsible for any environmental or energy shortfalls or losses arising from the use and operation of the Project.

§ 3.2 Schematic Design Phase Services

§ 3.2.1 As required by this Agreement, the Architect shall review the program and other information furnished by the Owner, and shall review laws, codes, and regulations applicable to the Architect's services.

§ 3.2.2 The Architect shall prepare, solely for use by the Owner, a preliminary evaluation of the Owner's program, schedule, budget for the Cost of the Work, Project site, the proposed procurement and delivery method, and other Initial Information, each in terms of the other, to gain a general understanding of the requirements of the Project. The Architect shall notify the Owner of (1) any inconsistencies discovered in the information, and (2) other information or consulting services that may be reasonably needed for the Project.

§ 3.2.3 The Architect shall present its preliminary evaluation to the Owner and, if applicable, the Owner's Representative and shall discuss with the Owner and if applicable the Owner's Representative, alternative approaches to design and construction of the Project. The Architect shall reach an understanding with the Owner regarding the requirements of the Project.

§ 3.2.4 Based on the Project requirements agreed upon with the Owner, the Architect shall prepare and present, for the Owner's approval, a preliminary design illustrating the scale and relationship of the Project components.

§ 3.2.5 Based on the Owner's approval of the preliminary design, the Architect shall prepare Schematic Design Documents for the Owner's approval. The Schematic Design Documents shall consist of drawings and other documents including a site plan, if appropriate, and preliminary building plans, sections and elevations; and may include some combination of study models, perspective sketches, or digital representations. Preliminary selections of major building systems and construction materials shall be noted on the drawings or described in writing.

§ 3.2.5.1 The Architect shall consider sustainable design alternatives, such as material choices and building orientation, together with other considerations based on program and aesthetics, in developing a design that is consistent with the Owner's program, schedule and budget for the Cost of the Work. The Owner may obtain more advanced sustainable design services as a Supplemental Service under Section 4.1.1.

§ 3.2.5.2 The Architect shall consider the value of alternative materials, building systems and equipment, together with other considerations based on program and aesthetics, in developing a design for the Project that is consistent with the Owner's program, schedule, and budget for the Cost of the Work.

§ 3.2.6 The Architect shall submit to the Owner an estimate of the Cost of the Work prepared in accordance with and subject to Sections 6.2 and 6.3.

§ 3.2.7 The Architect shall submit the Schematic Design Documents to the Owner and request the Owner's approval. Upon request of Owner's approval of the Schematic Design Documents, the Architect shall commence the Design Development Phase.

§ 3.3 Design Development Phase Services

§ 3.3.1 As required by this Agreement, Design Development Phase Services shall be based on the Owner's approval of the Schematic Design Documents, and on the Owner's authorization of any adjustments in the Project requirements and the budget for the Cost of the Work, the Architect shall prepare Design Development Documents for the Owner's approval. The Design Development Documents shall illustrate and describe the development of the approved Schematic Design Documents and shall consist of drawings and other documents including plans, sections, elevations, typical construction details, and diagrammatic layouts of building systems to fix and describe the size and character of the Project as to architectural, structural, mechanical and electrical systems, and other appropriate elements. The Design Development Documents shall also include outline specifications that identify major materials and systems and establish, in general, their quality levels.

§ 3.3.2 The Architect shall update the estimate of the Cost of the Work prepared in accordance with Section 6.3.

§ 3.3.3 The Architect shall submit the Design Development Documents to the Owner, advise the Owner of any adjustments to the estimate of the Cost of the Work, and request the Owner's approval. Upon receipt of Owner's approval of the Design Development Documents, the Architect shall commence the Construction Documents Phase.

§ 3.3.4 The Architect shall provide one (1) exterior design concept to the Owner for approval as part of Basic Services. Any additional design concepts shall be charged as an Additional Service in accordance with Article 4.3.

§ 3.4 Construction Documents Phase Services

§ 3.4.1 As required by this Agreement, Construction Documents Phase Services shall be based on the Owner's approval of the Design Development Documents, and on the Owner's authorization of any adjustments in the Project requirements and the budget for the Cost of the Work, the Architect shall prepare Construction Documents for the Owner's approval. The Construction Documents shall illustrate and describe the further development of the approved Design Development Documents and shall consist of Drawings and Specifications setting forth in detail the quality levels and performance criteria of materials and systems and other requirements for the construction of the Work. The Owner and Architect acknowledge that, in order to perform the Work, the Contractor will provide additional information, including Shop Drawings, Product Data, Samples and other similar submittals, which the Architect shall review in accordance with Section 3.6.4.

§ 3.4.2 The Architect shall use professional care to incorporate the written publicly available design requirements of governmental authorities having jurisdiction over the design of the Project into the Construction Documents.

§ 3.4.3 During the development of the Construction Documents, the Architect shall assist the Owner in the development and preparation of (1) procurement information that describes the time, place, and conditions of bidding, including bidding or proposal forms; (2) the form of agreement between the Owner and Contractor; and (3) the Conditions of the Contract for Construction (General, Supplementary and other Conditions). The Architect shall also compile a project manual that includes the Conditions of the Contract for Construction and Specifications and may include bidding requirements and sample forms.

§ 3.4.4 The Architect shall update the estimate for the Cost of the Work prepared in accordance with Section 6.3.

§ 3.4.5 The Architect shall submit the Construction Documents to the Owner, advise the Owner of any adjustments to the estimate of the Cost of the Work, take any action required under Section 6.5, and request the Owner's approval. Upon receipt of Owner's approval of the Construction Documents, the Architect shall commence the Bidding/Negotiation Phase.

§ 3.4.6 The Owner and Architect acknowledge that, given the nature of the design and construction process, certain inconsistencies, conflicts, errors and/or omissions may exist in the Construction Documents prepared by the Architect. It is further acknowledged and agreed that as long as the number and type of such inconsistencies, conflicts, errors and/or omissions are reasonable and consistent with reasonable skill and care, such inconsistencies, conflicts, errors and/or omissions shall not constitute a material breach of this Agreement or a deviation from the applicable standard of care set forth herein. Notwithstanding the foregoing, the Architect and its consultants shall modify or correct any errors or omissions in the Construction Documents at no additional cost to Owner.

§ 3.4.7 If, as a result of the Architect's failure to comply with the standard of care set forth in this Agreement, an error in the Construction Documents results in additional construction costs to the Owner, the Architect shall be responsible for compensating the Owner for additional construction costs for which the Architect is legally responsible in accordance with applicable law.

§ 3.4.8 If, as a result of the Architect's failure to comply with the standard of care set forth in this Agreement, an omission in the Construction Documents results in additional construction costs to the Owner, the Architect shall be responsible for compensating the Owner only for the additional costs related to adding the omitted item or element over and above that which the Owner would have paid had the omitted item or element been included in the original Construction Documents.

§ 3.4.9 All costs associated with the Architect's negligent errors or omissions which constitute "betterment" or "value added" to the Owner shall be borne by the Owner to the extent of such betterment or value added.

§ 3.5 Procurement Phase Services

§ 3.5.1 General

As required by this Agreement, the Architect shall assist the Owner in establishing a list of prospective contractors. Following the Owner's approval of the Construction Documents, the Architect shall assist the Owner in (1) obtaining either competitive bids or negotiated proposals; (2) confirming responsiveness of bids or proposals; (3) determining the successful bid or proposal, if any; and, (4) awarding and preparing contracts for construction.

§ 3.5.2 Competitive Bidding

§ 3.5.2.1 Bidding Documents shall consist of bidding requirements and proposed Contract Documents.

§ 3.5.2.2 The Architect shall assist the Owner in bidding the Project by:

- .1 facilitating the electronic reproduction and distribution of Bidding Documents to prospective bidders;
- .2 attending and assisting with a pre-bid conference for prospective bidders; and
- .3 preparing responses to questions from prospective bidders and providing clarifications and interpretations of the Bidding Documents to the prospective bidders in the form of addenda; and,
- .4 attending the opening of the bids.

§ 3.5.2.3 If the Bidding Documents permit substitutions, upon the Owner's written authorization, the Architect shall, as an Additional Service, consider written requests for substitutions and prepare and distribute addenda identifying approved substitutions to all prospective bidders.

§ 3.6 Construction Phase Services

§ 3.6.1 General

As required by this Agreement the Architect comply with the following under this Article 3.6.

§ 3.6.1.1 The Architect shall provide administration of the Contract between the Owner and the Contractor as set forth below and in AIA Document A201™-2017, General Conditions of the Contract for Construction to the extent required by this Agreement. If the Owner and Contractor modify AIA Document A201-2017, those modifications shall not affect the Architect's services under this Agreement unless the Owner and the Architect amend this Agreement in writing to include such modifications. The terms and conditions of this Agreement shall govern and control the Architect's services on the Project.

§ 3.6.1.2 The Architect shall advise and consult with the Owner during the Construction Phase Services. The Architect shall have authority to act on behalf of the Owner only to the extent provided in this Agreement. The Architect shall not have control over, charge of, or responsibility for the construction means, methods, techniques, sequences or procedures, or for jobsite safety, including, but not limited to safety precautions and programs in connection with the Work or compliance with any safety laws, standards, rules, regulations or guidelines governing the Work, nor shall the Architect be responsible for the Contractor's failure to perform the Work in accordance with the requirements of the Contract Documents. The Architect shall be responsible for the Architect's negligent acts or omissions, but shall not have control over or charge of, and shall not be responsible for, acts or omissions of the Contractor or of any other persons or entities performing portions of the Work.

§ 3.6.1.3 Subject to Section 4.3 and except as provided in Section 3.6.6.5, the Architect's responsibility to provide Construction Phase Services commences with the award of the Contract for Construction and terminates on the date the Architect issues the final Certificate for Payment.

§ 3.6.1.4 The Architect shall not be responsible for any aspect of design, procurement, erection, construction, monitoring, observation or use of any scaffolds, hoists, cranes, ladders, bracing or supports of any type on the Project, whether temporary or permanent, nor shall the Architect have responsibility for construction barricades, barriers, safety cones, tape, warning, signage, canopies or other similar devices of any kind, whether for vehicular or pedestrian traffic or otherwise on or around the Project site. No provision of this Agreement shall be interpreted to

confer upon the Architect any duty owed under common law, statute or regulation to construction workers or any other person regarding safety or the prevention of accidents at the Project.

§ 3.6.2 Evaluations of the Work

§ 3.6.2.1 The Architect shall visit the site at a mutually agreed upon number of site visits per project to become generally familiar with the progress and quality of the portion of the Work completed, and to determine, in general, if the Work observed is being performed in a manner indicating that the Work, when fully completed, will be in accordance with the Contract Documents. However, the Architect shall not be required to make exhaustive or continuous on-site inspections to check the quality or quantity of the Work. On the basis of the site visits, the Architect shall keep the Owner reasonably informed about the progress and quality of the portion of the Work completed, and promptly report to the Owner (1) known deviations from the Contract Documents, (2) known deviations from the most recent construction schedule submitted by the Contractor, and (3) defects and deficiencies observed in the Work.

§ 3.6.2.2 The Architect has the authority to recommend to the Owner that the Owner reject Work that does not conform to the Contract Documents. Subject to Owner's written approval, whenever the Architect considers it necessary or advisable, the Architect shall have the authority to require inspection or testing of the Work in accordance with the provisions of the Contract Documents, whether or not the Work is fabricated, installed or completed. However, neither this authority of the Architect nor a decision made in good faith either to exercise or not to exercise such authority shall give rise to a duty or responsibility of the Architect to the Contractor, Subcontractors, suppliers, their agents or employees, or other persons or entities performing portions of the Work, and the Architect shall not be responsible for defects or deficiencies of the Contractor, Subcontractors, or suppliers resulting from their failure to complete Work in accordance with the Contract Documents.

§ 3.6.2.3 The Architect shall interpret and decide matters concerning performance under, and requirements of, the Contract Documents on written request of either the Owner or Contractor. The Architect's response to such requests shall be made in writing within any time limits agreed upon or otherwise with reasonable promptness.

§ 3.6.2.4 Interpretations and decisions of the Architect shall be consistent with the intent of, and reasonably inferable from, the Contract Documents and shall be in writing or in the form of drawings. When making such interpretations and decisions, the Architect shall endeavor to secure faithful performance by both Owner and Contractor, shall not show partiality to either, and shall not be liable for results of interpretations or decisions rendered in good faith. The Architect's decisions on matters relating to aesthetic effect shall be final if consistent with the intent expressed in the Contract Documents.

§ 3.6.2.5 Unless the Owner and Contractor designate another person to serve as an Initial Decision Maker, as that term is defined in AIA Document A201-2017, the Architect shall render initial decisions on Claims between the Owner and Contractor as provided in the Contract Documents. In no event shall the Architect be liable for decisions made in such capacity if made in good faith.

§ 3.6.3 Certificates for Payment to Contractor

§ 3.6.3.1 The Architect shall review and certify the amounts due the Contractor and shall issue certificates in such amounts. The Architect's certification for payment shall constitute a representation to the Owner, based on the Architect's evaluation of the Work as provided in Section 3.6.2 and on the data comprising the Contractor's Application for Payment, that, to the best of the Architect's knowledge, information and belief, the Work has progressed to the point indicated, the quality of the Work is in general accordance with the Contract Documents, and that the Contractor is entitled to payment in the amount certified. The foregoing representations are subject to (1) an evaluation of the Work for conformance with the Contract Documents upon Substantial Completion, (2) results of subsequent tests and inspections, (3) correction of minor deviations from the Contract Documents prior to completion, and (4) specific qualifications expressed by the Architect.

§ 3.6.3.2 The issuance of a Certificate for Payment shall not be a representation that the Architect has (1) made exhaustive or continuous on-site inspections to check the quality or quantity of the Work, (2) reviewed construction means, methods, techniques, sequences or procedures, (3) reviewed copies of requisitions received from Subcontractors and suppliers and other data requested by the Owner to substantiate the Contractor's right to

payment, or (4) ascertained how or for what purpose the Contractor has used money previously paid on account of the Contract Sum.

§ 3.6.3.3 The Architect shall maintain a record of the Applications and Certificates for Payment.

§ 3.6.4 Submittals

§ 3.6.4.1 The Architect shall review the Contractor's submittal schedule when issued by the Contractor and shall not unreasonably delay or withhold approval of the schedule. The Architect's action in reviewing submittals shall be taken in accordance with the approved submittal schedule or, in the absence of an approved submittal schedule, with reasonable promptness while allowing sufficient time, in the Architect's professional judgment, to permit adequate review.

§ 3.6.4.2 The Architect shall review or take other appropriate action only upon the Contractor's submittals such as Shop Drawings, Product Data and Samples, that are required by the Contract Documents, but only for the limited purpose of checking for conformance with information given and the design concept expressed in the Contract Documents. Review of such submittals is not for the purpose of determining the accuracy and completeness of other information such as dimensions, quantities, and installation or performance specific details, of equipment or systems, which are the Contractor's responsibility. The Architect's review shall not constitute approval of safety precautions or construction means, methods, techniques, sequences or procedures. The Architect's approval of a specific item shall not indicate approval of an assembly of which the item is a component. Regardless of the review, notations or markups of the Architect on any submittal, shop drawing or product data, neither the Architect nor its consultants shall be responsible for any aspect of the submittal, shop drawing or product data which does not comply with the requirements of the Contract Documents, responsibility for which rests solely with the Contractor.

§ 3.6.4.3 If the Contract Documents specifically require the Contractor to provide professional design services or certifications by a design professional related to systems, materials, or equipment, the Architect or its consultants shall specify the appropriate performance and design criteria that such services must satisfy. Subject to the terms of Article 3.6.4.2, the Architect or its consultants shall retain Shop Drawings and other submittals related to the Work designed or certified by the Contractor's design professional, provided the submittals bear such professional's seal and signature when submitted to the Architect for informational purposes only. The Architect's review shall be for the limited purpose of checking for conformance with information given and the design concept expressed in the Contract Documents. The Architect and its consultants shall be entitled to rely upon, and shall not be responsible for, the adequacy and accuracy of the services, certifications, and approvals performed or provided by such design professionals and shall have no responsibility for any errors or omissions in the services or documentation provided by the Contractor's design professionals.

§ 3.6.4.4 Subject to Section 4.2, the Architect shall review and respond to requests for information about the Contract Documents. The Architect shall set forth, in the Contract Documents, the requirements for requests for information. Requests for information shall include, at a minimum, a detailed written statement that indicates the specific Drawings or Specifications in need of clarification and the nature of the clarification requested. The Architect's response to such requests shall be made in writing within any time limits agreed upon, or otherwise with reasonable promptness. If appropriate, the Architect shall prepare and issue supplemental Drawings and Specifications in response to the requests for information.

§ 3.6.4.5 The Architect shall maintain a record of submittals and copies of submittals supplied by the Contractor in accordance with the requirements of the Contract Documents.

§ 3.6.5 Changes in the Work

§ 3.6.5.1 The Architect may order minor changes in the Work that are consistent with the intent of the Contract Documents and do not involve an adjustment in the Contract Sum or an extension of the Contract Time. Subject to Section 4.2, the Architect shall prepare Change Orders and Construction Change Directives for the Owner's approval and execution in accordance with the Contract Documents.

§ 3.6.5.2 The Architect shall maintain records relative to changes in the Work under Article 3.6.5.1.

§ 3.6.6 Project Completion

§ 3.6.6.1 The Architect shall:

- .1 conduct on site reviews to determine the date or dates of Substantial Completion and the date of final completion;
- .2 issue Certificates of Substantial Completion;
- .3 forward to the Owner, for the Owner’s review and records, written warranties and related documents required by the Contract Documents and received from the Contractor; and,
- .4 issue a final Certificate for Payment based upon a final on site review indicating the Work observed by the Architect complies with the requirements of the Contract Documents.

§ 3.6.6.2 The Architect’s reviews per 3.6.6.1 and certain inspections shall be conducted with the Owner to check apparent conformance of the Work observed with the requirements of the Contract Documents and to verify the apparent accuracy and completeness of the punch list submitted to the Contractor of Work to be completed or corrected.

§ 3.6.6.3 The Architect’s reviews shall not be considered an approval or a warranty of the work, and shall in no manner relieve the Contractor from the obligations of the Project as set forth by the Contract Documents.

§ 3.6.6.4 When Substantial Completion has been achieved, the Architect shall inform the Owner about the balance of the Contract Sum remaining to be paid the Contractor, including the amount to be retained from the Contract Sum, if any, for final completion or correction of the Work.

§ 3.6.6.5 The Architect shall forward to the Owner the following information received from the Contractor: (1) consent of surety or sureties, if any, to reduction in or partial release of retainage or the making of final payment; (2) affidavits, receipts, releases and waivers of liens, or bonds indemnifying the Owner against liens; and (3) any other documentation required of the Contractor under the Contract Documents.

§ 3.6.6.6 Upon written request of the Owner, and prior to the expiration of one year from the date of Substantial Completion, the Architect shall, without additional compensation, conduct a meeting with the Owner to review the facility operations and performance.

ARTICLE 4 SUPPLEMENTAL AND ADDITIONAL SERVICES

§ 4.1 Supplemental Services

§ 4.1.1 The services listed below are not included in Basic Services but may be required for the Project as indicated in this Agreement. The Architect shall provide the listed Supplemental Services only if specifically designated in the table below as the Architect’s responsibility, and the Owner shall compensate the Architect as provided in Section 11.2. Unless otherwise specifically addressed in this Agreement, if neither the Owner nor the Architect is designated, or if indicated as ‘Not Provided,’ the parties agree that the listed Supplemental Service is not being provided for the Project. *(Designate the Architect’s Supplemental Services and the Owner’s Supplemental Services required for the Project by indicating whether the Architect or Owner shall be responsible for providing the identified Supplemental Service. Insert a description of the Supplemental Services in Section 4.1.2 below or attach the description of services as an exhibit to this Agreement.)*

| Supplemental Services | Responsibility <i>(Architect, Owner, or not provided)</i> |
|---|---|
| § 4.1.1.1 Programming | Architect / Owner |
| § 4.1.1.2 Multiple preliminary designs | Not Provided |
| § 4.1.1.3 Measured drawings | Not Provided |
| § 4.1.1.4 Existing facilities surveys | Not Provided |
| § 4.1.1.5 Site evaluation and planning | Architect / Owner |
| § 4.1.1.6 Building Information Modeling | Architect |
| § 4.1.1.7 Development of Building Information Models for post construction use | Not Provided |
| § 4.1.1.8 Civil Engineering | Architect |

AIA Document B101™ – 2017. Copyright © 1974, 1978, 1987, 1997, 2007 and 2017 by The American Institute of Architects. All rights reserved. WARNING: This AIA® Document is protected by U.S. Copyright Law and International Treaties. Unauthorized reproduction or distribution of this AIA® Document, or any portion of it, may result in severe civil and criminal penalties, and will be prosecuted to the maximum extent possible under the law. This draft was produced by AIA software at 09:37:27 CT on 01/15/2019 under Order No.1889929144 which expires on 10/09/2019, and is not for resale.

User Notes:

| Supplemental Services | Responsibility <i>(Architect, Owner, or not provided)</i> |
|---|---|
| § 4.1.1.9 Landscape design | Architect |
| § 4.1.1.10 Architectural interior design | Architect |
| § 4.1.1.11 Value analysis | Not Provided |
| § 4.1.1.12 Detailed cost estimating beyond that required in Section 6.3 | Architect / Owner: See Modifier Below |
| § 4.1.1.13 On-site project representation | Owner |
| § 4.1.1.14 Conformed documents for construction | Not Provided |
| § 4.1.1.15 As-designed record drawings | Architect |
| § 4.1.1.16 As-constructed record drawings | Owner (Constructor to Furnish) |
| § 4.1.1.17 Post-occupancy evaluation | Architect |
| § 4.1.1.18 Facility support services | Not Provided |
| § 4.1.1.19 Tenant-related services | Not Provided |
| § 4.1.1.20 Architect's coordination of the Owner's consultants | Architect / Owner |
| § 4.1.1.21 Telecommunications/data design | Not Provided |
| § 4.1.1.22 Security evaluation and planning | Not Provided |
| § 4.1.1.23 Commissioning | Owner |
| § 4.1.1.24 Sustainable Project Services pursuant to Section 4.1.3 | Not Provided |
| § 4.1.1.25 LEED Consultation | Not Provided |
| § 4.1.1.26 Fast-track design services | Not Provided |
| § 4.1.1.27 Multiple bid packages | Not Provided |
| § 4.1.1.28 Historic preservation | Not Provided |
| § 4.1.1.29 Furniture, furnishings, and equipment (FFE) Consultation | Architect |
| § 4.1.1.30 Alternates | Architect |
| § 4.1.1.31 Called Inspections | Not Provided |
| § 4.1.1.32 ICC-500 Facility Peer Review | Architect |
| § 4.1.1.33 Planning and Zoning and Permit Review Assistance | Architect: See modifier Below |

§ 4.1.2 Description of Supplemental Services

§ 4.1.2.1 A description of each Supplemental Service identified in Section 4.1.1 is provided below; refer to matrix above for which are included as part of the Architect's responsibility. *(Describe in detail the Architect's Supplemental Services identified in Section 4.1.1 or, if set forth in an exhibit, identify the exhibit. The AIA publishes a number of Standard Form of Architect's Services documents that can be included as an exhibit to describe the Architect's Supplemental Services.)*

1. Program: if applicable, the Architect shall utilize the program of space needs already documented and endorsed by the Owner (refer to Exhibit B, Preliminary Design Memorandum) and provide services to develop the concept budget, schedule and space program, as well as site development plan. The space program will consider the number, size, type of space and groupings which are to comprise the facility. This may also be a confirmation of the Owner's other preliminary project data. FGMA shall make presentations to the Owner prior to the Schematic Design phase of design, to affirm the Project scope, budgetary projections and schedule.
2. Multiple Preliminary Designs: Will not be provided. If so directed to perform as an Additional Service, the Architect would develop multiple graphic options for the Owner's consideration of building concept, scope

and space adjacencies, as well as site development. Space adjacency and site test fit plans would show the relationship between spaces and functions, and would precede Schematic Design.

3. Measured Drawings: will not be provided.
4. Existing Facilities Surveys: will not be provided.
5. Site Evaluation and Planning: criteria shall be developed for comparison and site usage options, as well as site due diligence investigations (if part of the Architect's responsibility as a Supplemental Service(s)). See below regarding land surveying and utilities documentation.
6. Building Information Modeling (BIM): if applicable, this service is a part of Basic Services. FGMA will utilize site aerial imagery and GIS imagery which are available from the public domain to underpin site planning, until a land survey would be provided for site design and documentation. Level of Development (LoD) shall be a blend of 100, 200, 300 and 350 in our documents.
7. Development of Building Information Models for post construction use: will not be provided.
8. Civil Engineering: included as a Supplemental Service, the Civil Engineer shall provide the design, engineering, documentation, bidding and construction administration for both on-site and off-site civil engineering aspects of the Project. Also included are services required to affect rezoning or building set back variance requests if applicable, subject to the limited quantity of meetings / presentations to City Planning and Zoning Commission per the below. Included as a Supplemental Service, Land Surveying and Title Commitments Research shall also be furnished by the Architect and shall include the following – establish and document site boundaries, document existing topography and features / improvements thereupon, and document utilities (see below), set-backs, easements and other encumbrances information as may be recorded and publicly available. An ALTA survey would not be performed as a Basic or Supplemental Service, nor would a plat consolidation, division or street vacation, nor a recording process for any of the above. Public utility markings coordination and documentation shall be included; private utility location markings may be coordinated and included if required, and likewise geotechnical borings if available at the time of surveying.
9. Landscape Design: included as a Supplemental Service, Landscape Design shall provide for the design, selection, bidding and construction administration for limited landscaping work. 'Limited' shall be understood to mean 'as required to comply with municipal ordinances and zoning requirements as apply to the Project site.'
10. Architectural Interior Design: included as a Supplemental Service, the interior design of building components that are fixed and a part of the building interior shall be included, including but not necessarily limited to those interior design building components of floor covering, wall coverings, ceilings and fixed casework. FFE Design Consultation is excluded from this service and is addressed below.
11. Value Analysis: will not be provided. If so directed to perform as an Additional Service, several building systems / component options would be developed within a building model to compare criteria such as: life cycle, energy cost, maintenance, operational cost, etc.
12. Detailed Cost Estimating: excluded per se, but modified as follows: included as a Supplemental Service shall be cost opinions provided at the conclusion of each design milestone. Also included shall be coordination meetings to review overall estimate with Owner, and to establish and document a concurrence regarding anticipated overall project cost before proceeding into the succeeding design milestone. Refer to 6.3 and 6.3.1. below for additional related information.
13. On-Site Project Representation (B207™-2008): Will not be provided. If so directed to perform as an Additional Service, the Architect shall provide part-time or full-time on-site representation to observe the progress, quality and performance of the construction is being performed within the intent of the Contract Documents.
14. Conformed Construction Documents: will not be provided. If so directed to perform as an Additional Service, the Architect shall provide drawings and specifications that have been revised to incorporate addenda, changes and/or modifications. Any discrepancy between the "Conformed Construction Documents" and the "Bidding Documents", the "Bidding Documents" shall control.
15. As-Designed Record Drawings: if applicable, the Architect will submit one paper copy and one electronic copy of the documents to the Owner as a part of Basic Services.
16. As-Constructed Record Drawings: a final set of documents incorporating all contractor revisions to the project as it was constructed would be produced by the Constructor(s), for review by Architect and submittal to the Owner.
17. Post-occupancy Evaluation: if applicable, the Architect shall meet with Owner's representatives approximately one year after the facility has been occupied to walk-thru the facility and discuss items of

- concern. This service has no explicit cost, but requires that the Owner provide access to facilities and personnel in order for the Architect to perform.
18. Facility Support Services (B210™-2007): will not be provided.
 19. Tenant-related Services: will not be provided.
 20. Coordination of Owner's Consultants: coordinate work of the consultants retained directly by the owner under separate contract from the Architect's consultants. If applicable, the Architect shall coordinate the Civil Engineer's service with Architect's Engineer and Consultants as a part of the Architect's Basic Services.
 21. Telecommunications/Data Design: will not be provided. If so directed to perform as an Additional Service, Architect shall provide services for the design, selection, bidding and construction administration of telecommunications and data equipment, systems, networks and operations.
 22. Security Evaluation and Planning (B206™-2007): will not be provided. If so directed to perform as an Additional Service, Architect shall provide one or more of these services that include Crime Prevention Through Environmental Design (CPTED) Plan Assessment, Facility Analysis, Risk Assessment and / or Security Design Concept review.
 23. Commissioning (B211™-2007): Owner and / or Constructor(s) shall provide verification that the installed mechanical and electrical systems are functioning and performing within the design criteria.
 24. Extensive Environmentally Responsible Design (Sustainable Project Services pursuant to Section 4.1.3): will not be provided. If so directed to perform as an Additional Service, the Architect and Consultants shall provide services for the design and documentation of extensive environmentally responsible design features that are pursued short of LEED certification.
 25. LEED® Certification (B214™-2007): will not be provided. If so directed to perform as an Additional Service, the Architect and Consultants shall provide specialized studies, reports, engineering and documentation and provide other services that are required for sustainable design by US Green Building Council (LEED), Green Globes or similar organizations for possible certification.
 26. Fast-track design services: will not be provided. If so directed to perform as an Additional Service, the Architect and Engineers shall provide phased bidding packages to fast track the project, refer to Sections 1.1.6 and 5.4.1.
 27. Multiple Bid Packages: will not be provided.
 28. Historic Preservation (B205™-2007): will not be provided.
 29. Furniture, Furnishings & Equipment (FFE) Consultation: FGMA will indicate furniture, furnishings and equipment in the partition and / or finish materials plans for the Project, such that the quantity, size arrangement and general type of FFE components can be ascertained and approved by the Owner. FGMA will likewise specify a scope for building signage, including interior elective and wayfinding as well as code-mandated / egress signage, and exterior building-mounted signage. Unless otherwise directed, FGMA will generate a cost opinion for FFE materials (including signage) to be procured for the project. If there are limited items of existing FFE which the Owner indicates they intend to carry over from an existing facility into the new facility, FGMA will review and identify those items with the Owner's guidance, document those items, and budget for temporary storage and relocation of certain limited existing FFE items into the new design once construction has been completed. It is understood by FGMA that the bulk of FFE shall be new in the Project. FGMA will support Owner in the selection and procurement of new FFE (including signage) via an Intergovernmental Purchasing Agreement (IPA). Services shall include facilitation of Vendor(s) bidding / pricing proposals, review of Vendor's submittals (which shall be based on / coordinated with the FGMA interior finish specifications and legend developed as part of the Project Interior Design per .10 above), and provision of comments and / or recommendations to the Owner for adjustments (if any). **NOTE:** Selection of and coordination with art, competitive bid specifications for FFE, bidding facilitation, comparison of multiple bid proposals for the same FFE item(s), extensive existing materials and items inventory and documentation, and installation oversight and punch-list are all excluded services.
 30. Alternates: if applicable, the Architect shall provide additional architectural and engineering services to incorporate into the Construction Documents bidding options for substitution of and / or addition or subtraction of materials, spaces and / or systems.
 31. Called Inspections: will not be provided. If so directed to perform as an Additional Service, the Architect and Engineer shall inspect components of construction when notified by the Contractor in accordance with the building authority.

32. ICC-500 Facility Peer Review: included as a Supplemental Service, the Architect and / or a sub-Consultant shall perform a code-mandated peer review of the design and documents in accordance with the building authority. Review of the construction, if required by code, may also be performed by the Architect and / or a sub-Consultant, in accordance with the Building Official's stipulations and in addition to the Building Inspector per the AHJ.
33. Planning and Zoning (P&Z) and Permit Review Assistance, and similar: included as a Supplemental Service, Architect shall prepare for and attend a maximum of four (4) such meetings / hearings, make submittals and presentations to and respond to questions from community meeting(s), Owner's Council meeting(s), hearing(s) or presentations to the Authorities Having Jurisdiction (AHJ), the Architectural Review Board (ARB) and / or the Planning and Zoning (P&Z) Commission as may have purview over the Project. This shall be in support of the permitting of the work. Additional meetings, presentations, etc. shall be an Additional Service. Submittals to and response to comments from AHJ in order to facilitate permitting of the Project shall be included as a Supplemental Service.

§ 4.1.2.2 A description of each Supplemental Service identified in Section 4.1.1 as the Owner's responsibility is provided below. *(Describe in detail the Owner's Supplemental Services identified in Section 4.1.1 or, if set forth in an exhibit, identify the exhibit.)*

«As indicated above within 4.1.2.1. Additional information to be provided upon request. »

§ 4.1.3 If the Owner identified a Sustainable Objective in Article 1, the Architect shall provide, as a Supplemental Service, the Sustainability Services required in a Sustainable Projects Exhibit, attached to this Agreement. The Owner shall compensate the Architect as provided in Section 11.2.

§ 4.2 Architect's Additional Services

The Architect may provide Additional Services after execution of this Agreement without invalidating the Agreement. Except for services required due to the fault of the Architect, any Additional Services provided in accordance with this Section 4.2 shall entitle the Architect to compensation pursuant to Section 11.3 and an appropriate adjustment in the Architect's schedule.

§ 4.2.1 Upon recognizing the need to perform the following Additional Services, the Architect shall notify the Owner with reasonable promptness and explain the facts and circumstances giving rise to the need. The Architect shall not proceed to provide the following Additional Services until the Architect receives the Owner's written authorization:

- .1 Services necessitated by a change in the Initial Information, previous instructions or approvals given by the Owner, or a material change in the Project including size, quality, complexity, the Owner's schedule or budget for Cost of the Work, or procurement or delivery method;
- .2 Services necessitated by the enactment or revision of codes, laws, or regulations, including changing or editing previously prepared Instruments of Service;
- .3 Changing or editing previously prepared Instruments of Service necessitated by official interpretations of applicable codes, laws or regulations that are either (a) contrary to specific interpretations by the applicable authorities having jurisdiction made prior to the issuance of the building permit, or (b) contrary to requirements of the Instruments of Service when those Instruments of Service were prepared in accordance with the applicable standard of care;
- .4 Services necessitated by decisions of the Owner not rendered in a timely manner or any other failure of performance on the part of the Owner or the Owner's consultants or contractors;
- .5 Preparing digital models or other design documentation for transmission to the Owner's consultants and contractors, or to other Owner-authorized recipients;
- .6 Preparation of design and documentation for alternate bid or proposal requests proposed by the Owner, if not addressed by this Agreement;
- .7 Preparation for, and attendance at more than two (2) public presentation(s), community meeting(s), Owner's Council meeting(s) or hearing(s) other than as indicated above in 4.1.2.1.33, and for anticipated meetings with or presentations to the Authorities Having Jurisdiction (AHJ) and / or the Planning and Zoning (P&Z) Commission as may have purview over the Project; note that attendance of any such meetings or presentations exceeding the quantity indicated above shall be an Additional Service;

- .8 Preparation for, and attendance at, a dispute resolution proceeding or legal proceeding, except where the Architect is party thereto;
 - .9 Evaluation of the qualifications of entities providing bids or proposals;
 - .10 Consultation concerning replacement of Work resulting from fire or other cause during construction;
 - .11 Assistance to the Initial Decision Maker, if other than the Architect.
- or,
- .12 Preparation and / or attendance at more than one (1) meeting with each utility provider.

§ 4.2.2 To avoid delay in the Construction Phase, the Architect shall provide the following Additional Services, notify the Owner with reasonable promptness, and explain the facts and circumstances giving rise to the need. If, upon receipt of the Architect's notice, the Owner determines that all or parts of the services are not required, the Owner shall give prompt written notice to the Architect of the Owner's determination. The Owner shall compensate the Architect for the services provided prior to the Architect's receipt of the Owner's notice.

- .1 Reviewing a Contractor's submittal out of sequence from the initial Project submittal schedule agreed to by the Architect;
- .2 Responding to the Contractor's requests for information that are not prepared in accordance with the Contract Documents or where such information is available to the Contractor from a careful study and comparison of the Contract Documents, field conditions, other Owner-provided information, Contractor-prepared coordination drawings, or prior Project correspondence or documentation;
- .3 Preparing Change Orders and Construction Change Directives that require evaluation of Contractor's proposals and supporting data, or the preparation or revision of Instruments of Service;
- .4 Evaluating an extensive number of Claims as the Initial Decision Maker; or,
- .5 Evaluating substitutions proposed by the Owner or Contractor and making subsequent revisions to Instruments of Service resulting therefrom.

§ 4.2.3 The Architect shall provide Construction Phase Services exceeding the limits set forth below as Additional Services. When the limits below are reached, the Architect shall notify the Owner:

- .1 «Up to two » («2 ») reviews of each Shop Drawing, Product Data item, sample and similar submittals of the Contractor
- .2 «Twice Monthly (2X per Month) » visits to the site by the Architect during construction
NOTE: Each Architect visit – intended to be concurrent with scheduled Owner / Architect / Contractor progress meetings during the work, but which may be scheduled differently by the Architect.
- .3 «One » («1 ») review for any portion of the Work to determine whether such portion of the Work appears substantially complete in accordance with the requirements of the Contract Documents
- .4 «One » («1 ») inspections for any portion of the Work to determine final completion.

§ 4.2.4 Except for services required under Section 3.6.6.5 and those services that do not exceed the limits set forth in Section 4.2.3, Construction Phase Services provided more than 60 days after (1) the date of Substantial Completion of the Work or (2) the initial date of Substantial Completion identified in the agreement between the Owner and Contractor, whichever is earlier, shall be compensated as Additional Services to the extent the Architect incurs additional cost in providing those Construction Phase Services.

§ 4.2.5 If the services covered by the this Agreement have not been completed within the time indicated herewith, through no fault of the Architect, extension of the Architect's services beyond that time shall be compensated as Additional Services. The time-line for completion of all Basic and Supplemental Services shall be limited to twenty-seven (27) months from the date of this Agreement.

ARTICLE 5 OWNER'S RESPONSIBILITIES

§ 5.1 Unless otherwise provided for under this Agreement or in an amendment to this Agreement, the Owner shall provide information in a timely manner regarding requirements for and limitations on the Project, including a written program, which shall set forth the Owner's objectives; schedule; constraints and criteria, including space requirements and relationships; flexibility; expandability; special equipment; systems; and site requirements.

§ 5.2 The Owner shall establish the Owner's budget for the Project, including (1) the budget for the Cost of the Work as defined in Section 6.1; (2) the Owner's other costs; and, (3) reasonable contingencies related to all of these

costs including design changes necessitated by unforeseen conditions or concealed conditions or a reasonable number of conflicts, errors or inconsistencies in the Contract Documents within the standard of care set forth herein. The Owner shall update the Owner's budget for the Project as necessary throughout the duration of the Project until final completion. If the Owner significantly increases or decreases the Owner's budget for the Cost of the Work, the Owner shall notify the Architect. The Owner and the Architect shall thereafter agree to a corresponding change in the Project's scope and quality.

§ 5.3 The Owner shall identify a representative authorized to act on the Owner's behalf with respect to the Project. The Owner shall render decisions and approve the Architect's submittals in a timely manner in order to avoid unreasonable delay in the orderly and sequential progress of the Architect's services.

§ 5.4 Unless furnished as a Supplemental Service, the Owner shall furnish surveys to describe physical characteristics, legal limitations and utility locations for the site of the Project, and a written legal description of the site. The surveys and legal information shall include, as applicable, grades and lines of streets, alleys, pavements and adjoining property and structures; designated wetlands; adjacent drainage; rights-of-way, restrictions, easements, encroachments, zoning, deed restrictions, boundaries and contours of the site; locations, dimensions, and other necessary data with respect to existing buildings, other improvements and trees; and information concerning available utility services and lines, both public and private, above and below grade, including inverts and depths. All the information on the survey shall be referenced to a Project benchmark.

§ 5.5 Unless furnished as a Supplemental Service, the Owner shall furnish services of geotechnical engineers, which may include test borings, test pits, determinations of soil bearing values, percolation tests, evaluations of hazardous materials, seismic evaluation, ground corrosion tests and resistivity tests, including necessary operations for anticipating subsoil conditions, with written reports and appropriate recommendations.

§ 5.6 The Owner shall provide the Supplemental Services designated as the Owner's responsibility in Section 4.1.1.

§ 5.7 If the Owner identified a Sustainable Objective in Article 1, the Owner shall fulfill its responsibilities as required in a Sustainable Projects Exhibit, attached to this Agreement.

§ 5.8 The Owner shall coordinate the services of its own consultants with those services provided by the Architect. Upon the Architect's request, the Owner shall furnish copies of the scope of services in the contracts between the Owner and the Owner's consultants. The Owner shall furnish the services of consultants other than those designated as the responsibility of the Architect in this Agreement, or authorize the Architect to furnish them as an Additional Service, when the Architect requests such services and demonstrates that they are reasonably required by the scope of the Project. The Owner shall require that its consultants and contractors maintain insurance, including professional liability insurance, as appropriate to the services or work provided.

§ 5.9 The Owner shall furnish tests, inspections and reports required by law or the Contract Documents, such as structural, mechanical, and chemical tests, tests for air and water pollution, and tests for hazardous materials.

§ 5.10 The Owner shall furnish all legal, insurance and accounting services, including auditing services, that may be reasonably necessary at any time for the Project to meet the Owner's needs and interests.

§ 5.11 The Owner shall provide prompt written notice to the Architect if the Owner becomes aware of any fault or defect in the Project, including errors, omissions or inconsistencies in the Architect's Instruments of Service.

§ 5.12 The Owner shall include the Architect in all communications with the Contractor that relate to or affect the Architect's services or professional responsibilities. The Owner shall promptly notify the Architect of the substance of any direct communications between the Owner and the Contractor otherwise relating to the Project. Communications by and with the Architect's consultants shall be through the Architect.

§ 5.13 Before executing the Contract for Construction, the Owner shall coordinate the Architect's duties and responsibilities set forth in the Contract for Construction with the Architect's services set forth in this Agreement. The Owner shall provide the Architect a copy of the executed agreement between the Owner and Contractor, including the General Conditions of the Contract for Construction.

§ 5.14 The Owner shall provide the Architect access to the Project site prior to commencement of the Work and shall obligate the Contractor to provide the Architect access to the Work wherever it is in preparation or progress.

§ 5.15 Within 15 days after receipt of a written request from the Architect, the Owner shall furnish the requested information as necessary and relevant for the Architect to evaluate, give notice of, or enforce lien rights.

§ 5.16 The Owner shall contract separately for the consulting services in this Article 5. Unless otherwise indicated herein, the services to be provided by Owner's consultants shall be performed by licensed professionals who shall affix their seals on the appropriate documents prepared by them. The Owner shall require its consultants to coordinate their drawings and other instruments of service with those of the Architect and to advise the Architect of any potential conflicts. The Architect shall have no responsibility for the components of the Project designed by Owner's consultants or for the adequacy of their drawings or other documentation. Review by the Architect of the work product of Owner's consultants is solely for consistency with the Architect's design concept of the Project. The Architect shall be entitled to rely on the technical sufficiency and timely delivery of documents and services furnished by those consultants in connection with such work product and shall not be required to review or verify calculations, designs or other documentation for compliance with applicable codes, laws, ordinances, rules and regulations nor shall Architect be responsible to discover errors or omissions in such documents or services. To the fullest extent permitted by law, the Owner shall defend, indemnify and hold harmless the Architect and its consultants from and against all claims, liabilities, damages, losses and expenses, including attorney's fees, arising out of services performed by Owner's consultants, including if or when Owner contends the Architect or its consultants should have discovered errors or omissions in the services of Owner's consultants.

§ 5.17 If the Owner deviates from or authorizes deviations, recorded or unrecorded, from the Contract Documents without the written agreement of the Architect, the Owner shall, to the fullest extent permitted by law, defend, indemnify and hold harmless the Architect and its consultants from and against all claims, liabilities, damages, losses and expenses, including attorney's fees, arising out of or resulting from such deviations.

§ 5.18 The Owner shall include in all contracts for construction Paragraphs 3.5 (Warranty by Contractor) and 3.18 (Indemnification) from the AIA A201 General Conditions of the Contract for Construction 2017 Edition.

§ 5.19 The Owner shall include in all contracts for construction, the requirement that the contractor(s) name the Owner and Architect as additional insureds on all liability insurance policies required of the contractors for the Project. Such insurance shall be required to be primary and non-contributory over any insurance carried by the Owner or Architect.

ARTICLE 6 COST OF THE WORK

§ 6.1 For purposes of this Agreement, the Cost of the Work shall be the total cost to the Owner to construct all elements of the Project designed or specified by the Architect and shall include contractors' general conditions costs, overhead and profit. The Cost of the Work also includes the reasonable value of labor, materials, and equipment, donated to, or otherwise furnished by, the Owner. The Cost of the Work does not include the compensation of the Architect or the Owner's Representative; the costs of the land, rights-of-way, financing, or contingencies for changes in the Work; or other costs that are the responsibility of the Owner.

§ 6.1.1 Cost of the Work shall include an Owner's contingency in the amount of three (3%) percent of the Owner's budget for construction to cover ambiguities, inconsistencies, incompleteness, errors or omissions in the Instruments of Service as defined in Article 7 herein furnished by the Architect. The Architect shall not be liable for errors or omissions unless such errors or omissions both exceed the contingency and constitute a breach of the standard of care set forth herein.

§ 6.2 The Owner's budget for the Cost of the Work is provided in Initial Information and shall be adjusted throughout the Project as required under Sections 5.2, 6.4 and 6.5. Evaluations of the Owner's budget for the Cost of the Work, and the preliminary estimate of the Cost of the Work and updated estimates of the Cost of the Work, prepared by the Architect, represent the Architect's judgment as a design professional. It is recognized, however, that neither the Architect nor the Owner has control over the cost of labor, materials, or equipment; the Contractor's methods of determining bid prices; or competitive bidding, market, or negotiating conditions. Accordingly, the

Architect cannot and does not warrant or represent that bids or negotiated prices will not vary from the Owner's budget for the Cost of the Work, or from any estimate of the Cost of the Work, or evaluation, prepared or agreed to by the Architect, and the Architect shall have no responsibility for such variance nor shall the Architect be responsible if the bids or Cost of the Work exceeds the estimate or Owner's budget.

§ 6.3 In preparing estimates of the Cost of Work, the Architect shall be permitted to include contingencies for design, bidding, and price escalation; to determine what materials, equipment, component systems, and types of construction are to be included in the Contract Documents; to recommend reasonable adjustments in the program and scope of the Project; and to include design alternates as may be necessary to adjust the estimated Cost of the Work to meet the Owner's budget. The Architect's estimate of the Cost of the Work shall be based on current area, volume or similar conceptual estimating techniques. If the Owner requires a detailed estimate of the Cost of the Work, the Architect shall provide such an estimate, if identified as the Architect's responsibility in Section 4.1.1, as a Supplemental Service.

§ 6.3.1 At the conclusion of each design phase prior to competitive bidding of the Project, the Architect shall provide to the Owner an updated estimate for Mechanical, Plumbing, Fire Protection, Electrical, and Low Voltage systems designed for the Project. Concurrently, the Owner shall provide to the Architect an updated estimate of the Civil / Site, Structural and Building systems and scope of services. The Architect, Owner and Owner's Representative shall collaborate to review and consolidate these estimates into a single, updated Cost of the Work with summary and detail. Until each design phase Cost of the Work update is complete and endorsed by all parties, the succeeding design phase shall not be undertaken.

§ 6.4 If, through no fault of the Architect, the Procurement Phase has not commenced within sixty (60) days after the Architect submits the Construction Documents to the Owner, the Owner's budget for the Cost of the Work shall be adjusted to reflect changes in the general level of prices in the applicable construction market.

§ 6.5 If at any time the Architect's estimate of the Cost of the Work exceeds the Owner's budget for the Cost of the Work, the Architect shall make appropriate recommendations to the Owner to adjust the Project's size, quality, or budget for the Cost of the Work, and the Owner shall cooperate with the Architect in making such adjustments.

§ 6.6 If the Owner's budget for the Cost of the Work at the conclusion of the Construction Documents Phase Services is exceeded by the lowest bona fide bid or negotiated proposal, the Owner shall

- .1 give written approval of an increase in the budget for the Cost of the Work;
- .2 authorize rebidding or renegotiating of the Project within a reasonable time;
- .3 terminate in accordance with Section 9.5;
- .4 in consultation with the Architect, revise the Project program, scope, or quality as required to reduce the Cost of the Work; or,
- .5 implement any other mutually acceptable alternative.

§ 6.7 If the Owner chooses to proceed under sub-Section 6.6.4, the Architect shall modify the Construction Documents as necessary to comply with the Owner's budget for the Cost of the Work at the conclusion of the Construction Documents Phase Services, or the budget as adjusted under sub-Section 6.6.1. If the Owner requires the Architect to modify the Construction Documents because the lowest bona fide bid or negotiated proposal exceeds the Owner's budget for the Cost of the Work due to market conditions the Architect could not reasonably anticipate, the Owner shall compensate the Architect for the modifications as an Additional Service pursuant to Section 11.3; otherwise the Architect's services for modifying the Construction Documents shall be without additional compensation. In any event, the Architect's modification of the Construction Documents shall be the limit of the Architect's responsibility under this Article 6.

ARTICLE 7 COPYRIGHTS AND LICENSES

§ 7.1 The Architect and the Owner warrant that in transmitting Instruments of Service, or any other information, the transmitting party is the copyright owner of such information or has permission from the copyright owner to transmit such information for its use on the Project.

§ 7.2 The Architect and the Architect's consultants shall be deemed the authors and owners of their respective Instruments of Service, including the Drawings and Specifications, and shall retain all common law, statutory and

other reserved rights, including copyrights. Submission or distribution of Instruments of Service to meet official regulatory requirements or for similar purposes in connection with the Project is not to be construed as publication in derogation of the reserved rights of the Architect and the Architect's consultants.

§ 7.3 The Architect grants to the Owner a nonexclusive license to use the Architect's Instruments of Service solely and exclusively for purposes of constructing, using and maintaining the Project or for informational purposes only in connection with any alteration or addition to the Project, provided that the Owner substantially performs its obligations under this Agreement, including prompt payment of all sums due pursuant to Article 9 and Article 11. The Architect shall obtain similar nonexclusive licenses from the Architect's consultants consistent with this Agreement. The license granted under this section permits the Owner to authorize the Contractor, Subcontractors, Sub-subcontractors, and suppliers, as well as the Owner's consultants and separate contractors, to reproduce applicable portions of the Instruments of Service, subject to any protocols established pursuant to Section 1.3, solely and exclusively for use in performing services or construction for the Project. If the Architect rightfully terminates this Agreement for cause as provided in Section 9.4, or the Architect is terminated without cause as provided in Section 9.5, the license granted in this Section 7.3 shall terminate.

§ 7.3.1 In the event the Owner uses the Instruments of Service without retaining the authors of the Instruments of Service or obtaining the Architect's written consent, the Owner releases the Architect and Architect's consultant(s) from all claims and causes of action arising from such uses. The Owner, to the extent permitted by law, further agrees to defend, indemnify and hold harmless the Architect and its consultants from all costs and expenses, including the cost of defense, related to claims and causes of action asserted by any third person or entity to the extent such costs and expenses arise from the Owner's use of the Instruments of Service under this Section 7.3.1.

§ 7.4 Except for the licenses granted in this Article 7, no other license or right shall be deemed granted or implied under this Agreement. The Owner shall not assign, delegate, sublicense, pledge or otherwise transfer any license granted herein to another party without the prior written agreement of the Architect. Any unauthorized use of the Instruments of Service shall be at the Owner's sole risk and without liability to the Architect and the Architect's consultants.

§ 7.5 The following provisions apply to any Instruments of Service provided in electronic format:

§ 7.5.1 The official Instruments of Service are the signed and sealed Drawings and Specification issued in paper format for use in connection with the Project.

§ 7.5.2 The Architect may, in its sole discretion, provide for use to Owner from time to time upon request by Owner for its convenience, the Architect's Building Information Model ("BIM") and/or CAD or other electronic files. The design documents, calculations, drawings, details, backgrounds and other information prepared by the Architect in electronic format, whether incorporated in the BIM Model or in CAD format (hereinafter collectively referred to as "Electronic Instruments of Service") are instruments of the professional architectural service intended for use only in connection with the construction of this Project. The Electronic Instruments of Service are and shall remain the property of the Architect.

§ 7.5.3 The Electronic Instruments of Service are provided for the sole purpose of communicating the state of the design to date, and Owner acknowledges that such Electronic Instruments of Service may not be final or complete. Owner acknowledges that use by Owner or its contractors of the Electronic Instruments of Service is at the user's sole risk and responsibility. Under no circumstances shall such Electronic Instruments of Service be used on other projects, for additions to the project or completion of this Project by another design professional without the written consent of the Architect. Any such use or reuse by the Owner or others without the written consent of the Architect for the specific purpose intended shall be at the Owner's sole risk and without liability to the Architect. The Owner shall, to the fullest extent permitted by law, defend, indemnify and hold harmless the Architect and its consultants from all claims, liabilities, damages, losses and expenses, including attorney's fees, arising out of or resulting from Owner's use or reuse of the Electronic Instruments of Service or any use in violation of any terms of this Article. Any such consent or adaptation for use shall entitle the Architect to further compensation at rates to be mutually agreed upon by the Owner and Architect.

§ 7.5.4 Because of the possibility that data stored on electronic media or delivered in machine readable format may be subject to alteration, deterioration, incompatibility, translation and readability issues, whether inadvertently or otherwise, the Owner agrees that the Architect shall not have responsibility or liability in connection with the completeness, accuracy or correctness of the Electronic Instruments of Service, information and data and use by the Owner is at its sole risk and responsibility. The Architect reserves the right to retain hard copy originals of all Project documentation delivered to the owner in machine readable form, which originals shall be referred to and shall govern in the event of any inconsistency between the hard copy originals and the electronic information. No software shall be transferred to the Owner. The Owner's right to use electronic files or to use the paper Instruments of Service prepared by the Architect is conditional upon the owner in full compliance with its obligations under this Agreement.

§ 7.5.5 The Owner acknowledges and understands that the use and automated conversion of information and data in the Electronic Instruments of Service provided by the Architect to a derivative work, model, or alternate system, format or version by the owner may not be accomplished without the introduction of inexactitudes, anomalies, or errors. In the event the Electronic Instruments of Service provided are so used or converted, the Owner agrees to assume all risks associated therewith and releases the Architect from such responsibility and to the fullest extent permitted by law, the Owner shall defend, indemnify and hold harmless the Architect and its consultants from and against all claims, liabilities, losses, damages and expenses, including, but not limited to attorney's fees, arising in connection therewith.

§ 7.5.6 The electronic data files are intended to work only as described in the Agreement. These files are compatible only on AutoCAD or Revit Architecture, latest releases. The Owner shall verify drawing release number and file format with the Architect at the time the files are transmitted. The Architect makes no warranty as to the compatibility of the Electronic Instruments of Service.

§ 7.6 Except as otherwise stated in Section 7.3, the provisions of this Article 7 shall survive the termination of this Agreement.

ARTICLE 8 CLAIMS AND DISPUTES

§ 8.1 General

§ 8.1.1 The Owner and Architect shall commence all claims and causes of action against the other and arising out of or related to this Agreement, whether in contract, tort, or otherwise, in accordance with the requirements of the binding dispute resolution method selected in this Agreement and within the period specified by applicable law, but in any case not more than 10 years after the date of Substantial Completion of the Work. The Owner and Architect waive all claims and causes of action not commenced in accordance with this Section 8.1.1.

§ 8.1.2 To the extent damages are covered by property insurance, the Owner and Architect waive all rights against each other and against the contractors, consultants, agents, and employees of the other for damages, except such rights as they may have to the proceeds of such insurance as set forth in AIA Document A201-2017, General Conditions of the Contract for Construction. The Owner or the Architect, as appropriate, shall require of the contractors, consultants, agents, and employees of any of them, similar waivers in favor of the other parties enumerated herein. The Owner shall name or require that its contractor(s) name the Architect as an additional insured under any Builders Risk or property insurance policy maintained on the Project.

§ 8.1.3 The Architect and Owner waive consequential damages, including, without limitation, lost profits, lost revenues, delay damages, loss of market, financing charges, interest and overhead for claims, disputes, or other matters in question, arising out of or relating to this Agreement or the services provided. This mutual waiver is applicable, without limitation, to all consequential damages due to either party's termination of this Agreement, except as specifically provided in Section 9.7.

§ 8.1.4 To the fullest extent permitted by law, the Architect, its successors, assigns and guarantors, shall indemnify and hold harmless the Owner, its officers, directors, employees and the Owner's Representative from and against all proceedings, suits, actions, claims, damages, losses and expenses, including but not limited to, reasonable attorney fees, court costs, and the cost of the appellate proceedings to the extent such are recoverable under law, and directly and to the extent any negligent or intentional actions, acts, errors, mistakes or omissions caused by the Architect related to services in the performance of this Contract, including but not limited to, any Subcontractor of Architect

or anyone directly or indirectly employed by any of them or anyone for whose acts any of them are liable and any injury or damages are claimed by any of the Architect's and Subcontractor's employees, on a comparative basis of fault. Nothing herein shall require Architect to indemnify Owner or Owner's Representative or their other Consultants or Contractors for negligence or liability on the part of those parties.

§ 8.1.5 Insurance provisions set forth in this agreement are separate and independent from the indemnity provisions of this paragraph and shall not be construed in any way to limit the scope and magnitude of the indemnity provisions. The indemnity provisions of this paragraph shall not be construed in any way to limit the scope and magnitude and applicability of the insurance provisions.

§ 8.2 Mediation

§ 8.2.1 Any claim, dispute or other matter in question arising out of or related to this Agreement shall be subject to mediation as a condition precedent to litigation. If such matter relates to or is the subject of a lien arising out of the Architect's services, the Architect may proceed in accordance with applicable law to comply with the lien notice or filing deadlines prior to resolution of the matter by mediation or by litigation. Prior to the initiation of mediation, on written notice of either party to the other of an intent to mediate a dispute under this Agreement, each party shall designate a representative and shall meet within five (5) days after service of the notice of intent to mediate. The parties shall attempt to resolve the dispute through negotiation within ten (10) days of the meeting. Should the parties be unable to agree on a resolution with such ten (10) day period, the parties shall proceed to mediation as set forth herein.

§ 8.2.2 The Owner and Architect shall endeavor to resolve claims, disputes and other matters in question between them by mediation, which, unless the parties mutually agree otherwise, shall be administered by the American Arbitration Association or such forum as the Owner and Architect may mutually agree in accordance with the administrative rules of the mediation service in effect on the date of this Agreement. A request for mediation shall be made in writing, delivered to the other party to this Agreement, and filed with the person or entity administering the mediation. The request may be made concurrently with the filing of a complaint but, in such event, mediation shall proceed in advance of litigation, which shall be stayed pending mediation for a period of 60 days from the date of filing, unless stayed for a longer period by agreement of the parties or court order.

§ 8.2.3 The parties shall share the mediator's fee and any filing fees equally. The mediation shall be held in the place where the Project is located, unless another location is mutually agreed upon. Agreements reached in mediation shall be enforceable as settlement agreements in any court having jurisdiction thereof.

§ 8.2.4 If the parties do not resolve a dispute through mediation pursuant to this Section 8.2, the method of binding dispute resolution shall be the following:

(Check the appropriate box.)

Arbitration pursuant to Section 8.3 of this Agreement

Litigation in a court of competent jurisdiction

Other: *(Specify)*

§ 8.2.4.1 If the Owner and Architect do not select a method of binding dispute resolution, or do not subsequently agree in writing to a binding dispute resolution method other than litigation, the dispute will be resolved in a court of competent jurisdiction.

ARTICLE 9 TERMINATION OR SUSPENSION

§ 9.1 If the Owner fails to make payments to the Architect in accordance with this Agreement, such failure shall be considered substantial nonperformance and cause for termination or, at the Architect's option, cause for suspension of performance of services under this Agreement. If the Architect elects to suspend services, the Architect shall give seven days' written notice to the Owner before suspending services. In the event of a suspension of services, the Architect shall have no liability to the Owner for delay or damage caused the Owner because of such suspension of services. The Owner shall promptly pay the Architect all sums due prior to suspension and any expenses incurred in

the interruption of the Architect's services. Upon resumption of the Architect's services, the Architect's fees for the remaining services and the time schedules shall be equitably adjusted.

§ 9.2 If the Owner suspends the Project, the Architect shall be compensated for services performed prior to notice of such suspension. When the Project is resumed, the Architect shall be compensated for expenses incurred in the interruption and resumption of the Architect's services. The Architect's fees for the remaining services and the time schedules shall be equitably adjusted.

§ 9.3 If the Owner suspends the Project for more than 90 cumulative days for reasons other than the fault of the Architect, the Architect may terminate this Agreement by giving not less than seven days' written notice.

§ 9.4 Either party may terminate this Agreement upon not less than seven days' written notice should the other party fail substantially to perform in accordance with the terms of this Agreement through no fault of the party initiating the termination.

§ 9.5 The Owner may terminate this Agreement upon not less than seven days' written notice to the Architect for the Owner's convenience and without cause. The Owner shall not pay any unearned fee if the Owner terminates this Agreement, but shall pay any fees incurred to that point by Architect.

§ 9.6 If the Owner terminates this Agreement for its convenience pursuant to Section 9.5, or the Architect terminates this Agreement pursuant to Section 9.3, the Owner shall compensate the Architect for services performed prior to termination, Reimbursable Expenses incurred, and costs attributable to termination, including the costs attributable to the Architect's termination of consultant agreements.

§ 9.7 In addition to any amounts paid under Section 9.6, if the Owner terminates this Agreement for its convenience pursuant to Section 9.5, or the Architect terminates this Agreement pursuant to Section 9.3, the Owner shall pay to the Architect the following fees: *(Set forth below the amount of any termination or licensing fee, or the method for determining any termination or licensing fee.)*

- .1 Termination Fee:
«To be determined. »
- .2 Licensing Fee if the Owner intends to continue using the Architect's Instruments of Service:
«To be determined. »

§ 9.8 Except as otherwise expressly provided herein, this Agreement shall terminate one year from the date of Substantial Completion.

§ 9.9 The Owner's rights to use the Architect's Instruments of Service in the event of a termination of this Agreement are set forth in Article 7 and Section 9.7. In no event shall Architect be liable for any errors or omissions in the Instruments of Service if Owner is rightfully terminated under Sections 9.1, 9.3 or 9.4 or Architect is terminated under Section 9.5.

ARTICLE 10 MISCELLANEOUS PROVISIONS

§ 10.1 This Agreement shall be governed by the law of the State of Missouri.

§ 10.2 Terms in this Agreement, if not defined herein, shall have the same meaning as those in AIA Document A201-2017, General Conditions of the Contract for Construction.

§ 10.3 The Owner and Architect, respectively, bind themselves, their agents, successors, assigns, and legal representatives to this Agreement. Neither the Owner nor the Architect shall assign this Agreement without the written consent of the other, except that the Owner may assign this Agreement to a lender providing financing for the Project if the lender agrees to assume the Owner's rights and obligations under this Agreement, including any payments due to the Architect by the Owner prior to the assignment.

§ 10.4 If the Owner requests the Architect to execute certificates, the proposed language of such certificates shall be submitted to the Architect for review at least 14 days prior to the requested dates of execution. If the Owner requests the Architect to execute consents reasonably required to facilitate assignment to a lender, the Architect shall execute all such consents that are consistent with this Agreement, provided the proposed consent is submitted to the Architect for review at least 14 days prior to execution. The Architect shall not be required to execute certificates or consents that would require knowledge, services, or responsibilities beyond the scope of this Agreement.

§ 10.5 Nothing contained in this Agreement shall create a contractual relationship with, or a cause of action in favor of, a third party against either the Owner or Architect.

§ 10.6 Unless otherwise required in this Agreement, the Architect shall have no responsibility for the discovery, presence, handling, removal or disposal of, or exposure of persons to, hazardous materials or toxic substances in any form at the Project site.

§ 10.7 The Architect shall have the right to include photographic or artistic representations of the design of the Project among the Architect's promotional and professional materials. The Architect shall be given reasonable access to the completed Project to make such representations. However, the Architect's materials shall not include the Owner's confidential or proprietary information if the Owner has previously advised the Architect in writing of the specific information considered by the Owner to be confidential or proprietary. The Owner shall provide professional credit for the Architect in the Owner's promotional materials for the Project. This Section 10.7 shall survive the termination of this Agreement unless the Owner terminates this Agreement for cause pursuant to Section 9.4.

§ 10.8 If the Architect or Owner receives non-public information specifically designated as "confidential" or "business proprietary," the receiving party shall keep such information strictly confidential and shall not disclose it to any other person except as set forth in Section 10.8.1. This Section 10.8 shall survive the termination of this Agreement.

§ 10.8.1 The receiving party may disclose "confidential" or "business proprietary" information after 7 days' notice to the other party, when required by law, arbitrator's order, or court order, including a subpoena or other form of compulsory legal process issued by a court or governmental entity, or to the extent such information is reasonably necessary for the receiving party to defend itself in any dispute. The receiving party may also disclose such information to its employees, consultants, or contractors in order to perform services or work solely and exclusively for the Project, provided those employees, consultants and contractors are subject to the restrictions on the disclosure and use of such information as set forth in this Section 10.8.

§ 10.9 The invalidity of any provision of the Agreement shall not invalidate the Agreement or its remaining provisions. If it is determined that any provision of the Agreement violates any law, or is otherwise invalid or unenforceable, then that provision shall be revised to the extent necessary to make that provision legal and enforceable. In such case the Agreement shall be construed, to the fullest extent permitted by law, to give effect to the parties' intentions and purposes in executing the Agreement.

ARTICLE 11 COMPENSATION

§ 11.1 For the Architect's Basic and Supplemental Services described and indicated as by the Architect under Article 3 and Article 4, the Owner shall compensate the Architect as follows:

- .1 Stipulated Sum: For Phase I (Conceptualization: Program Verification, Scope-Cost-Schedule Documentation) Services:
Thirty-Nine Thousand One Hundred Dollars and No Cents (\$39,100.00)
- .2 Stipulated Sum: For Phase II (Implementation: Schematic Design (SD), Design Development (DD), Construction Documents (CD), Procurement (Bidding and Negotiation / BN), and Contract Administration (CA) – see below for OPTION regarding CA) Services:
Four Hundred Eighty-Eight Thousand Five Hundred Ninety Dollars and No Cents (\$488,590.00)

- .3 OPTIONAL: Hourly (Time and Material) Basis, Not to Exceed the Following Limit: For Construction (Contract Administration / CA) Phase Services ONLY: Deduct from the above 11.1.2 Stipulated Sum and invoice Hourly not to exceed ***Ninety-Four Thousand Dollars and No Cents (\$94,000.00)***

Refer to Exhibit C, Fee Matrix for additional related information.

§ 11.2 For the Architect's Supplemental Services designated in Section 4.1.1 and for any Sustainability Services required pursuant to Section 4.1.3, the Owner shall compensate the Architect as follows: *(Insert amount of, or basis for, compensation. If necessary, list specific services to which particular methods of compensation apply.)*

1. Programming: will be provided to confirm the Owner's program as a Supplemental Service. If additional programming efforts are requested, Additional Service fees shall be billed hourly using hourly billing rates or on mutually agreed upon stipulated sum once the scope is finalized
2. Multiple Preliminary Design: will not be provided as a Basic or Supplemental Service. If required, Additional Service fees shall be billed hourly using hourly billing rates or on mutually agreed upon stipulated sum once the scope is finalized
3. Measured Drawings: will not be provided.
4. Existing Facilities Surveys: will not be provided.
5. Site Evaluation and Planning: service fees for the indicated scope of service are included with fee under Section 11.1.
6. Building Information Modeling: included in basic services fee under section 11.1
7. Development of Building Information Models for Post Construction Use: will not be provided as a Basic or Supplemental Service. If required, Additional Service fees shall be billed hourly using hourly billing rates or on mutually agreed upon stipulated sum once the scope is finalized.
8. Civil Engineering: service fees for the indicated scope of service are included with fee under Section 11.1. If required to perform additional service beyond what is stipulated above, service fees shall be billed hourly using hourly billing rates or on mutually agreed upon stipulated sum once the scope is finalized for this Additional Service.
9. Landscape Design: service fees for the indicated scope of service are included with fee under Section 11.1. If required to perform additional service beyond what is stipulated above, service fees shall be billed hourly using hourly billing rates or on mutually agreed upon stipulated sum once the scope is finalized for this Additional Service.
10. Architectural Interior Design: service fees for the indicated scope of service are included with fee under Section 11.1. If required to perform additional service beyond what is stipulated above, service fees shall be billed hourly using hourly billing rates or on mutually agreed upon stipulated sum once the scope is finalized for this Additional Service.
11. Value Analysis: will not be provided as a Basic or Supplemental Service. If required, Additional Service fees shall be billed hourly using hourly billing rates or on mutually agreed upon stipulated sum once the scope is finalized.
12. Detailed Cost Estimating: service fees for the indicated scope of service are included with fee under Section 11.1. If required to perform additional service beyond what is stipulated above, service fees shall be billed hourly using hourly billing rates or on mutually agreed upon stipulated sum once the scope is finalized for this Additional Service.
13. On-site Project Representation: will not be provided as a Basic or Supplemental Service. If required, Additional Service fees shall be billed hourly using hourly billing rates or on mutually agreed upon stipulated sum once the scope is finalized.
14. Conformed Construction Documents: will not be provided as a Basic or Supplemental Service. If required, Additional Service fees shall be billed hourly using hourly billing rates or on mutually agreed upon stipulated sum once the scope is finalized.
15. As-Designed Record Drawings: included in Basic Service fee under section 11.1; to include all changes to the Project which were documented by the Architect during the construction of the work. For any changes not documented by the Architect during the work (including but not necessarily limited to red lines and field notes by Owner or Owner's Representative, changes by Utilities or their assigns, changes by the Constructor(s), and similar), Additional Service fees shall be billed hourly using hourly billing rates or based on mutually agreed upon stipulated sum.
16. As-Constructed Record Documents: will not be provided.

17. Post-occupancy Evaluation: included in Basic Services but no fee charged for this service per se .
18. Facility Support Services: will not be provided as a Basic or Supplemental Service. If required, Additional Service fees shall be billed hourly using hourly billing rates or on mutually agreed upon stipulated sum once the scope is finalized.
19. Tenant-related services: will not be provided as a Basic or Supplemental Service. If required, Additional Service fees shall be billed hourly using hourly billing rates or on mutually agreed upon stipulated sum once the scope is finalized.
20. Architect's coordination of the Owner's consultants: included in basic services fee under section 11.1.
21. Telecommunications / Data Design: will not be provided as a Basic or Supplemental Service. If required, Additional Service fees shall be billed hourly using hourly billing rates or on mutually agreed upon stipulated sum once the scope is finalized.
22. Security evaluation and planning: will not be provided as a Basic or Supplemental Service. If required, Additional Service fees shall be billed hourly using hourly billing rates or on mutually agreed upon stipulated sum once the scope is finalized.
23. Commissioning, Extensive Environmentally Responsible and LEED® Certification: will not be provided as a Basic or Supplemental Service. If required, Additional Service fees shall be billed hourly using hourly billing rates or on mutually agreed upon stipulated sum once the scope is finalized.
24. Sustainable project services pursuant to section 4.1.3: will not be provided as a Basic or Supplemental Service. If required, Additional Service fees shall be billed hourly using hourly billing rates or based on mutually agreed upon stipulated sum.
25. LEED Consultation: will not be provided as a Basic or Supplemental Service. If required, Additional Service fees shall be billed hourly using hourly billing rates or based on mutually agreed upon stipulated sum.
26. Fast-track Design Services: will not be provided as a Basic or Supplemental Service. If required, Additional Service fees shall be billed hourly using hourly billing rates or on mutually agreed upon stipulated sum once the scope is finalized.
27. Multiple Bid Packages: will not be provided as a Basic or Supplemental Service. If required, Additional Service fees shall be billed hourly using hourly billing rates or on mutually agreed upon stipulated sum once the scope is finalized.
28. Historic Preservation: will not be provided as a Basic or Supplemental Service. If required, Additional Service fees shall be billed hourly using hourly billing rates or on mutually agreed upon stipulated sum once the scope is finalized.
29. Furniture, Furnishings & Equipment (FFE) Consultation: service fees for the indicated scope of service are included with fee under Section 11.1. If required to perform additional service beyond what is stipulated above, service fees shall be billed hourly using hourly billing rates or on mutually agreed upon stipulated sum once the scope is finalized for this Additional Service.
30. Alternates: service fees for Alternates shall be either a percentage of the Cost of the Work, billed hourly using hourly billing rates and/or based on mutually agreed upon stipulated sum determined by the complexity of alternate.
31. Called Inspections: will not be provided as a Basic or Supplemental Service. If required, Additional Service fees shall be billed hourly using hourly billing rates or on mutually agreed upon stipulated sum once the scope is finalized.
32. ICC-500 Peer Review: service fees for the indicated scope of service are included with fee under Section 11.1. .
33. Planning and Zoning (P&Z) and Permit Review Assistance: beyond a maximum two (2) meetings / presentations to or hearings before Planning and Zoning on behalf of the project, and beyond a maximum two (2) meetings / presentations to the AHJ for permitting of the Project (for a maximum total of four (4) meetings), Additional Service fees shall be billed hourly using hourly billing rates or based on mutually agreed upon stipulated sum. Submittals by the Architect and any revisions with follow-up submittals to AHJ to support permitting of the Building and Structure shall also be included in basic service fee under section 11.1.

§ 11.3 For Additional Services that may arise during the course of the Project, including those under Section 4.2, the Owner shall compensate the Architect as follows: *(Insert amount of, or basis for, compensation.)*

«To be determined on individual tasks as assigned and incorporated into an amendment to this Agreement. »

§ 11.4 Compensation for Additional Services of the Architect's consultants when not included in Section 11.2 or 11.3, shall be the amount invoiced to the Architect one and one tenth (1.1): *(Insert amount of, or basis for computing, Architect's consultants' compensation for Supplemental or Additional Services.)*

«Refer to amendment(s) to this Agreement. »

§ 11.5 When compensation for Basic Services is based on a stipulated sum or a percentage basis, the proportion of compensation for each phase of services shall be as follows:

| | | | | |
|------------------------------|-----------------|-----------|-------|----|
| Schematic Design Phase | «ten » | percent (| «10 » | %) |
| Design Development Phase | «seventeen » | percent (| «17 » | %) |
| Construction Documents Phase | «thirty-seven » | percent (| «37 » | %) |
| Procurement Phase | «five » | percent (| «05 » | %) |
| Construction Phase | «thirty-one » | percent (| «31 » | %) |
| « » | | | | |

§ 11.7 The hourly billing rates for services of the Architect and the Architect's consultants are set forth below. The rates shall be adjusted periodically in accordance with the Architect's and Architect's consultants' normal review practices. *(If applicable, attach an exhibit of hourly billing rates or insert them below.)*

«See Exhibit A – FGM Architects Hourly Rate Schedule. »

| Employee or Category | Rate (\$0.00) |
|----------------------|---------------|
|----------------------|---------------|

§ 11.8 Compensation for Reimbursable Expenses

§ 11.8.1 Reimbursable Expenses are in addition to compensation for Basic, Supplemental, and Additional Services and include expenses incurred by the Architect and the Architect's consultants directly related to the Project, as follows:

- .1 Transportation and authorized out-of-town travel and sustenance;
- .2 Long distance services, dedicated data and communication services, teleconferences, Project web sites, and extranets;
- .3 Permitting and other fees required by Authorities Having Jurisdiction (AHJs) over the Project and which are paid to AHJs by the Architect on behalf of the Owner;
- .4 Printing, reproductions, plots, and standard form documents;
- .5 Postage, handling, and delivery;
- .6 Expense of overtime work requiring higher than regular rates, if authorized in advance by the Owner;
- .7 Renderings, physical models, mock-ups, professional photography, and presentation materials requested by the Owner or required for the Project;
- .8 If required by the Owner, and with the Owner's prior written approval, the Architect's consultants' expenses of professional liability insurance dedicated exclusively to this Project, or the expense of additional insurance coverage or limits in excess of that normally maintained by the Architect's consultants;
- .9 All taxes levied on professional services and on reimbursable expenses;
- .10 Site office expenses;
- .11 Registration fees and any other fees charged by the Certifying Authority or by other entities as necessary to achieve the Sustainable Objective; and,
- .12 Other similar Project-related expenditures.

§ 11.8.2 For Reimbursable Expenses the compensation shall be the expenses incurred by the Architect and the Architect's consultants plus «ten » percent («10 » %) of the expenses incurred. Total Reimbursable Expenses are not to exceed **\$8,200** (*eight thousand two hundred dollars and no cents*) without written authorization by the Owner.

§ 11.9 Architect's Insurance. If the types and limits of coverage required in Section 2.5 are in addition to the types and limits the Architect normally maintains, the Owner shall pay the Architect for the additional costs incurred by the Architect for the additional coverages as set forth below: *(Insert the additional coverages the Architect is required to obtain in order to satisfy the requirements set forth in Section 2.5, and for which the Owner shall reimburse the Architect.)*

§ 11.10 Payments to the Architect

§ 11.10.1 Initial Payments

§ 11.10.1.1 An initial payment of «zero» (\$ «0.00 ») shall be made upon execution of this Agreement and is the minimum payment under this Agreement. It shall be credited to the Owner's account in the final invoice.

§ 11.10.1.2 If a Sustainability Certification is part of the Sustainable Objective, an initial payment to the Architect of « » (\$ « ») shall be made upon execution of this Agreement for registration fees and other fees payable to the Certifying Authority and necessary to achieve the Sustainability Certification. The Architect's payments to the Certifying Authority shall be credited to the Owner's account at the time the expense is incurred.

§ 11.10.2 Progress Payments

§ 11.10.2.1 Unless otherwise agreed, payments for services shall be made monthly in proportion to services performed. Payments are due and payable upon presentation of the Architect's invoice. Amounts unpaid thirty-five (35) days after the invoice date shall bear interest at the rate entered below, or in the absence thereof at the legal rate prevailing from time to time at the principal place of business of the Architect. *(Insert rate of monthly or annual interest agreed upon.)*

«To be determined» « TBD% »

§ 11.10.2.2 The Owner shall not withhold amounts from the Architect's compensation to impose a penalty or liquidated damages on the Architect, or to offset sums requested by or paid to contractors for the cost of changes in the Work, unless the Architect agrees or has been found liable for the amounts in a binding dispute resolution proceeding.

§ 11.10.2.3 Records of Reimbursable Expenses, expenses pertaining to Supplemental and Additional Services, and services performed on the basis of hourly rates shall be available to the Owner at mutually convenient times.

ARTICLE 12 SPECIAL TERMS AND CONDITIONS

Special terms and conditions that modify this Agreement are as follows: *(Include other terms and conditions applicable to this Agreement.)*

§ 12.1 the Owner and Architect have reviewed the risks, rewards and benefits of the Project to each and the Architect's total compensation for services. The Owner agrees that, to the fullest extent permitted by law, the Architect's total liability to the Owner for any and all claims, damages, losses and expenses of any kind and nature, whether in tort, contract or otherwise, arising out of this Agreement or the services provided by the Architect shall not exceed the total amount of fees received by Architect

§ 12.2 Any claims arising out of this Agreement shall be brought against the contracting parties and not against any individual director, officer or employee of a party.

§ 12.3 Any written notices provided for in this Agreement and copies of all correspondence shall be transmitted to the Owner and the Architect at the following addresses:

Architect:
FGM Architects Inc.
One Metropolitan Square, Suite 1945
St. Louis, Missouri 63102

Owner:
City of Washington, Missouri
405 Jefferson Street
Washington, Missouri 63090
c/o Washington Fire Department

ARTICLE 13 SCOPE OF THE AGREEMENT

§ 13.1 This Agreement represents the entire and integrated agreement between the Owner and the Architect and supersedes all prior negotiations, representations or agreements, either written or oral. This Agreement may be amended only by written instrument signed by both the Owner and Architect.

§ 13.2 This Agreement is comprised of the following documents identified below:

- .1 AIA Document B101™–2017, Standard Form Agreement Between Owner and Architect
- .2 Exhibits:
 - Exhibit A – FGM Architects Hourly Rate Schedule
 - Exhibit B – Preliminary Design Memorandum
 - Exhibit C – Fee Matrix

This Agreement entered into as of the day and year first written above.

OWNER (Signature)

« »

(Printed name and title)



ARCHITECT (Signature)
«Kevin W. Meyer, AIA »
«Managing Director »

(Printed name, title, and license number, if required)

ARCHITECT (Signature)
«Joshua N. Mandell, AIA, NCARB, LEED AP BD+C »
«Principal-in-Charge »



ARCHITECT (Signature)
«Joshua N. Mandell, AIA, NCARB, LEED AP BD+C »
«Principal-in-Charge »

DRAFT AIA® Document A201™ - 2017

General Conditions of the Contract for Construction

for the following PROJECT:

(Name and location or address)

«New Satellite Fire Facility»
« City of Washington, Missouri / Washington Fire Department»
« 200 East 14th Street »
Washington, Missouri 63090 »
«Telephone Number: 636.390.1020

FGM Project Number: 24-XXXX

THE OWNER:

(Name and address)

« City of Washington, Missouri »« »
« 405 Jefferson Street
Washington, Missouri 63090»
«Telephone Number: 636.390.1010 « »

THE ARCHITECT:

(Name and address)

« FGM Architects Inc. »« »
«One Metropolitan Square, Suite 1945 »
« Telephone Number: 314.439.1601 »
« Fax Number: 314.439.1602 »

TABLE OF ARTICLES

- 1 GENERAL PROVISIONS
- 2 OWNER
- 3 CONTRACTOR
- 4 ARCHITECT
- 5 SUBCONTRACTORS
- 6 CONSTRUCTION BY OWNER OR BY SEPARATE CONTRACTORS
- 7 CHANGES IN THE WORK
- 8 TIME
- 9 PAYMENTS AND COMPLETION
- 10 PROTECTION OF PERSONS AND PROPERTY
- 11 INSURANCE AND BONDS

ADDITIONS AND DELETIONS:

The author of this document has added information needed for its completion. The author may also have revised the text of the original AIA standard form. An *Additions and Deletions Report* that notes added information as well as revisions to the standard form text is available from the author and should be reviewed.

This document has important legal consequences. Consultation with an attorney is encouraged with respect to its completion or modification.

For guidance in modifying this document to include supplementary conditions, see AIA Document A503™, Guide for Supplementary Conditions.

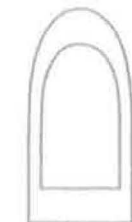

ELECTRONIC COPYING of any portion of this AIA® Document to another electronic file is prohibited and constitutes a violation of copyright laws as set forth in the footer of this document.

- 12 UNCOVERING AND CORRECTION OF WORK
- 13 MISCELLANEOUS PROVISIONS
- 14 TERMINATION OR SUSPENSION OF THE CONTRACT
- 15 CLAIMS AND DISPUTES



INDEX

(Topics and numbers in bold are Section headings.)

Acceptance of Nonconforming Work

9.6.6, 9.9.3, **12.3**

Acceptance of Work

9.6.6, 9.8.2, 9.9.3, 9.10.1, 9.10.3, **12.3**

Access to Work

3.16, 6.2.1, 12.1

Accident Prevention

10

Acts and Omissions

3.2, 3.3.2, 3.12.8, 3.18, 4.2.3, 8.3.1, 9.5.1, 10.2.5,

10.2.8, 13.3.2, 14.1, 15.1.2, 15.2

Addenda

1.1.1

Additional Costs, Claims for

3.7.4, 3.7.5, 10.3.2, 15.1.5

Additional Inspections and Testing

9.4.2, 9.8.3, 12.2.1, **13.4**

Additional Time, Claims for

3.2.4, 3.7.4, 3.7.5, 3.10.2, 8.3.2, **15.1.6**

Administration of the Contract

3.1.3, **4.2**, 9.4, 9.5

Advertisement or Invitation to Bid

1.1.1

Aesthetic Effect

4.2.13

Allowances

3.8

Applications for Payment

4.2.5, 7.3.9, 9.2, **9.3**, 9.4, 9.5.1, 9.5.4, 9.6.3, 9.7, 9.10

Approvals

2.1.1, 2.3.1, 2.5, 3.1.3, 3.10.2, 3.12.8, 3.12.9,

3.12.10.1, 4.2.7, 9.3.2, 13.4.1

Arbitration

8.3.1, 15.3.2, **15.4**

ARCHITECT

4

Architect, Definition of

4.1.1

Architect, Extent of Authority

2.5, 3.12.7, 4.1.2, 4.2, 5.2, 6.3, 7.1.2, 7.3.4, 7.4, 9.2,

9.3.1, 9.4, 9.5, 9.6.3, 9.8, 9.10.1, 9.10.3, 12.1, 12.2.1,

13.4.1, 13.4.2, 14.2.2, 14.2.4, 15.1.4, 15.2.1

Architect, Limitations of Authority and

Responsibility

2.1.1, 3.12.4, 3.12.8, 3.12.10, 4.1.2, 4.2.1, 4.2.2,

4.2.3, 4.2.6, 4.2.7, 4.2.10, 4.2.12, 4.2.13, 5.2.1, 7.4,

9.4.2, 9.5.4, 9.6.4, 15.1.4, 15.2

Architect's Additional Services and Expenses

2.5, 12.2.1, 13.4.2, 13.4.3, 14.2.4

Architect's Administration of the Contract

3.1.3, 3.7.4, 15.2, 9.4.1, 9.5

Architect's Approvals

2.5, 3.1.3, 3.5, 3.10.2, 4.2.7

Architect's Authority to Reject Work

3.5, 4.2.6, 12.1.2, 12.2.1

Architect's Copyright

1.1.7, 1.5

Architect's Decisions

3.7.4, 4.2.6, 4.2.7, 4.2.11, 4.2.12, 4.2.13, 4.2.14, 6.3,

7.3.4, 7.3.9, 8.1.3, 8.3.1, 9.2, 9.4.1, 9.5, 9.8.4, 9.9.1,

13.4.2, 15.2

Architect's Inspections

3.7.4, 4.2.2, 4.2.9, 9.4.2, 9.8.3, 9.9.2, 9.10.1, 13.4

Architect's Instructions

3.2.4, 3.3.1, 4.2.6, 4.2.7, 13.4.2

Architect's Interpretations

4.2.11, 4.2.12

Architect's Project Representative

4.2.10

Architect's Relationship with Contractor

1.1.2, 1.5, 2.3.3, 3.1.3, 3.2.2, 3.2.3, 3.2.4, 3.3.1, 3.4.2,

3.5, 3.7.4, 3.7.5, 3.9.2, 3.9.3, 3.10, 3.11, 3.12, 3.16,

3.18, 4.1.2, 4.2, 5.2, 6.2.2, 7, 8.3.1, 9.2, 9.3, 9.4, 9.5,

9.7, 9.8, 9.9, 10.2.6, 10.3, 11.3, 12, 13.3.2, 13.4, 15.2

Architect's Relationship with Subcontractors

1.1.2, 4.2.3, 4.2.4, 4.2.6, 9.6.3, 9.6.4, 11.3

Architect's Representations

9.4.2, 9.5.1, 9.10.1

Architect's Site Visits

3.7.4, 4.2.2, 4.2.9, 9.4.2, 9.5.1, 9.9.2, 9.10.1, 13.4

Asbestos

10.3.1

Attorneys' Fees

3.18.1, 9.6.8, 9.10.2, 10.3.3

Award of Separate Contracts

6.1.1, 6.1.2

Award of Subcontracts and Other Contracts for Portions of the Work

5.2

Basic Definitions

1.1

Bidding Requirements

1.1.1

Binding Dispute Resolution

8.3.1, 9.7, 11.5, 13.1, 15.1.2, 15.1.3, 15.2.1, 15.2.5,

15.2.6.1, 15.3.1, 15.3.2, 15.3.3, 15.4.1

Bonds, Lien

7.3.4.4, 9.6.8, 9.10.2, 9.10.3

Bonds, Performance, and Payment

7.3.4.4, 9.6.7, 9.10.3, **11.1.2**, 11.1.3, **11.5**

Building Information Models Use and Reliance

1.8

Building Permit

3.7.1

Capitalization

1.3

Certificate of Substantial Completion

9.8.3, 9.8.4, 9.8.5

Certificates for Payment

4.2.1, 4.2.5, 4.2.9, 9.3.3, **9.4**, 9.5, 9.6.1, 9.6.6, 9.7,

9.10.1, 9.10.3, 14.1.1.3, 14.2.4, 15.1.4

Certificates of Inspection, Testing or Approval
13.4.4
Certificates of Insurance
9.10.2
Change Orders
1.1.1, 3.4.2, 3.7.4, 3.8.2.3, 3.11, 3.12.8, 4.2.8, 5.2.3,
7.1.2, 7.1.3, 7.2, 7.3.2, 7.3.7, 7.3.9, 7.3.10, 8.3.1,
9.3.1.1, 9.10.3, 10.3.2, 11.2, 11.5, 12.1.2
Change Orders, Definition of
7.2.1
CHANGES IN THE WORK
2.2.2, 3.11, 4.2.8, 7, 7.2.1, 7.3.1, 7.4, 8.3.1, 9.3.1.1,
11.5
Claims, Definition of
15.1.1
Claims, Notice of
1.6.2, 15.1.3
CLAIMS AND DISPUTES
3.2.4, 6.1.1, 6.3, 7.3.9, 9.3.3, 9.10.4, 10.3.3, 15, 15.4
Claims and Timely Assertion of Claims
15.4.1
Claims for Additional Cost
3.2.4, 3.3.1, 3.7.4, 7.3.9, 9.5.2, 10.2.5, 10.3.2, 15.1.5
Claims for Additional Time
3.2.4, 3.3.1, 3.7.4, 6.1.1, 8.3.2, 9.5.2, 10.3.2, 15.1.6
Concealed or Unknown Conditions, Claims for
3.7.4
Claims for Damages
3.2.4, 3.18, 8.3.3, 9.5.1, 9.6.7, 10.2.5, 10.3.3, 11.3,
11.3.2, 14.2.4, 15.1.7
Claims Subject to Arbitration
15.4.1
Cleaning Up
3.15, 6.3
Commencement of the Work, Conditions Relating to
2.2.1, 3.2.2, 3.4.1, 3.7.1, 3.10.1, 3.12.6, 5.2.1, 5.2.3,
6.2.2, 8.1.2, 8.2.2, 8.3.1, 11.1, 11.2, 15.1.5
Commencement of the Work, Definition of
8.1.2
Communications
3.9.1, 4.2.4
Completion, Conditions Relating to
3.4.1, 3.11, 3.15, 4.2.2, 4.2.9, 8.2, 9.4.2, 9.8, 9.9.1,
9.10, 12.2, 14.1.2, 15.1.2
COMPLETION, PAYMENTS AND
9
Completion, Substantial
3.10.1, 4.2.9, 8.1.1, 8.1.3, 8.2.3, 9.4.2, 9.8, 9.9.1,
9.10.3, 12.2, 15.1.2
Compliance with Laws
2.3.2, 3.2.3, 3.6, 3.7, 3.12.10, 3.13, 9.6.4, 10.2.2,
13.1, 13.3, 13.4.1, 13.4.2, 13.5, 14.1.1, 14.2.1.3,
15.2.8, 15.4.2, 15.4.3
Concealed or Unknown Conditions
3.7.4, 4.2.8, 8.3.1, 10.3
Conditions of the Contract
1.1.1, 6.1.1, 6.1.4

Consent, Written
3.4.2, 3.14.2, 4.1.2, 9.8.5, 9.9.1, 9.10.2, 9.10.3, 13.2,
15.4.4.2
Consolidation or Joinder
15.4.4
**CONSTRUCTION BY OWNER OR BY
SEPARATE CONTRACTORS**
1.1.4, 6
Construction Change Directive, Definition of
7.3.1
Construction Change Directives
1.1.1, 3.4.2, 3.11, 3.12.8, 4.2.8, 7.1.1, 7.1.2, 7.1.3,
7.3, 9.3.1.1
Construction Schedules, Contractor's
3.10, 3.11, 3.12.1, 3.12.2, 6.1.3, 15.1.6.2
Contingent Assignment of Subcontracts
5.4, 14.2.2.2
Continuing Contract Performance
15.1.4
Contract, Definition of
1.1.2
**CONTRACT, TERMINATION OR
SUSPENSION OF THE**
5.4.1.1, 5.4.2, 11.5, 14
Contract Administration
3.1.3, 4, 9.4, 9.5
Contract Award and Execution, Conditions Relating
to
3.7.1, 3.10, 5.2, 6.1
Contract Documents, Copies Furnished and Use of
1.5.2, 2.3.6, 5.3
Contract Documents, Definition of
1.1.1
Contract Sum
2.2.2, 2.2.4, 3.7.4, 3.7.5, 3.8, 3.10.2, 5.2.3, 7.3, 7.4,
9.1, 9.2, 9.4.2, 9.5.1.4, 9.6.7, 9.7, 10.3.2, 11.5, 12.1.2,
12.3, 14.2.4, 14.3.2, 15.1.4.2, 15.1.5, 15.2.5
Contract Sum, Definition of
9.1
Contract Time
1.1.4, 2.2.1, 2.2.2, 3.7.4, 3.7.5, 3.10.2, 5.2.3, 6.1.5,
7.2.1.3, 7.3.1, 7.3.5, 7.3.6, 7, 7, 7.3.10, 7.4, 8.1.1,
8.2.1, 8.2.3, 8.3.1, 9.5.1, 9.7, 10.3.2, 12.1.1, 12.1.2,
14.3.2, 15.1.4.2, 15.1.6.1, 15.2.5
Contract Time, Definition of
8.1.1
CONTRACTOR
3
Contractor, Definition of
3.1, 6.1.2
**Contractor's Construction and Submittal
Schedules**
3.10, 3.12.1, 3.12.2, 4.2.3, 6.1.3, 15.1.6.2
Contractor's Employees
2.2.4, 3.3.2, 3.4.3, 3.8.1, 3.9, 3.18.2, 4.2.3, 4.2.6,
10.2, 10.3, 11.3, 14.1, 14.2.1.1
Contractor's Liability Insurance
11.1

Contractor's Relationship with Separate Contractors and Owner's Forces
 3.12.5, 3.14.2, 4.2.4, 6, 11.3, 12.2.4
 Contractor's Relationship with Subcontractors
 1.2.2, 2.2.4, 3.3.2, 3.18.1, 3.18.2, 4.2.4, 5, 9.6.2, 9.6.7, 9.10.2, 11.2, 11.3, 11.4
 Contractor's Relationship with the Architect
 1.1.2, 1.5, 2.3.3, 3.1.3, 3.2.2, 3.2.3, 3.2.4, 3.3.1, 3.4.2, 3.5.1, 3.7.4, 3.10, 3.11, 3.12, 3.16, 3.18, 4.2, 5.2, 6.2.2, 7, 8.3.1, 9.2, 9.3, 9.4, 9.5, 9.7, 9.8, 9.9, 10.2.6, 10.3, 11.3, 12, 13.4, 15.1.3, 15.2.1
 Contractor's Representations
 3.2.1, 3.2.2, 3.5, 3.12.6, 6.2.2, 8.2.1, 9.3.3, 9.8.2
 Contractor's Responsibility for Those Performing the Work
 3.3.2, 3.18, 5.3, 6.1.3, 6.2, 9.5.1, 10.2.8
 Contractor's Review of Contract Documents
 3.2
 Contractor's Right to Stop the Work
 2.2.2, 9.7
 Contractor's Right to Terminate the Contract
 14.1
 Contractor's Submittals
 3.10, 3.11, 3.12, 4.2.7, 5.2.1, 5.2.3, 9.2, 9.3, 9.8.2, 9.8.3, 9.9.1, 9.10.2, 9.10.3
 Contractor's Superintendent
 3.9, 10.2.6
 Contractor's Supervision and Construction Procedures
 1.2.2, 3.3, 3.4, 3.12.10, 4.2.2, 4.2.7, 6.1.3, 6.2.4, 7.1.3, 7.3.4, 7.3.6, 8.2, 10, 12, 14, 15.1.4
 Coordination and Correlation
 1.2, 3.2.1, 3.3.1, 3.10, 3.12.6, 6.1.3, 6.2.1
 Copies Furnished of Drawings and Specifications
 1.5, 2.3.6, 3.11
 Copyrights
 1.5, **3.17**
 Correction of Work
 2.5, 3.7.3, 9.4.2, 9.8.2, 9.8.3, 9.9.1, 12.1.2, **12.2**, 12.3, 15.1.3.1, 15.1.3.2, 15.2.1
Correlation and Intent of the Contract Documents
1.2
Cost, Definition of
7.3.4
 Costs
 2.5, 3.2.4, 3.7.3, 3.8.2, 3.15.2, 5.4.2, 6.1.1, 6.2.3, 7.3.3.3, 7.3.4, 7.3.8, 7.3.9, 9.10.2, 10.3.2, 10.3.6, 11.2, 12.1.2, 12.2.1, 12.2.4, 13.4, 14
Cutting and Patching
3.14, 6.2.5
 Damage to Construction of Owner or Separate Contractors
 3.14.2, 6.2.4, 10.2.1.2, 10.2.5, 10.4, 12.2.4
 Damage to the Work
 3.14.2, 9.9.1, 10.2.1.2, 10.2.5, 10.4, 12.2.4
 Damages, Claims for
 3.2.4, 3.18, 6.1.1, 8.3.3, 9.5.1, 9.6.7, 10.3.3, 11.3.2, 11.3, 14.2.4, 15.1.7

Damages for Delay
 6.2.3, 8.3.3, 9.5.1.6, 9.7, 10.3.2, 14.3.2
Date of Commencement of the Work, Definition of
8.1.2
Date of Substantial Completion, Definition of
8.1.3
Day, Definition of
8.1.4
 Decisions of the Architect
 3.7.4, 4.2.6, 4.2.7, 4.2.11, 4.2.12, 4.2.13, 6.3, 7.3.4, 7.3.9, 8.1.3, 8.3.1, 9.2, 9.4, 9.5.1, 9.8.4, 9.9.1, 13.4.2, 14.2.2, 14.2.4, 15.1, 15.2
Decisions to Withhold Certification
 9.4.1, **9.5**, 9.7, 14.1.1.3
 Defective or Nonconforming Work, Acceptance, Rejection and Correction of
 2.5, 3.5, 4.2.6, 6.2.3, 9.5.1, 9.5.3, 9.6.6, 9.8.2, 9.9.3, 9.10.4, 12.2.1
 Definitions
 1.1, 2.1.1, 3.1.1, 3.5, 3.12.1, 3.12.2, 3.12.3, 4.1.1, 5.1, 6.1.2, 7.2.1, 7.3.1, 8.1, 9.1, 9.8.1, 15.1.1
Delays and Extensions of Time
3.2, 3.7.4, 5.2.3, 7.2.1, 7.3.1, 7.4, 8.3, 9.5.1, 9.7, 10.3.2, 10.4, 14.3.2, 15.1.6, 15.2.5
Digital Data Use and Transmission
1.7
 Disputes
 6.3, 7.3.9, 15.1, 15.2
Documents and Samples at the Site
3.11
Drawings, Definition of
1.1.5
 Drawings and Specifications, Use and Ownership of
 3.11
 Effective Date of Insurance
 8.2.2
Emergencies
10.4, 14.1.1.2, 15.1.5
 Employees, Contractor's
 3.3.2, 3.4.3, 3.8.1, 3.9, 3.18.2, 4.2.3, 4.2.6, 10.2, 10.3.3, 11.3, 14.1, 14.2.1.1
 Equipment, Labor, or Materials
 1.1.3, 1.1.6, 3.4, 3.5, 3.8.2, 3.8.3, 3.12, 3.13, 3.15.1, 4.2.6, 4.2.7, 5.2.1, 6.2.1, 7.3.4, 9.3.2, 9.3.3, 9.5.1.3, 9.10.2, 10.2.1, 10.2.4, 14.2.1.1, 14.2.1.2
 Execution and Progress of the Work
 1.1.3, 1.2.1, 1.2.2, 2.3.4, 2.3.6, 3.1, 3.3.1, 3.4.1, 3.7.1, 3.10.1, 3.12, 3.14, 4.2, 6.2.2, 7.1.3, 7.3.6, 8.2, 9.5.1, 9.9.1, 10.2, 10.3, 12.1, 12.2, 14.2, 14.3.1, 15.1.4
 Extensions of Time
 3.2.4, 3.7.4, 5.2.3, 7.2.1, 7.3, 7.4, 9.5.1, 9.7, 10.3.2, 10.4, 14.3, 15.1.6, **15.2.5**
Failure of Payment
 9.5.1.3, **9.7**, 9.10.2, 13.5, 14.1.1.3, 14.2.1.2
 Faulty Work
 (See Defective or Nonconforming Work)
Final Completion and Final Payment
 4.2.1, 4.2.9, 9.8.2, **9.10**, 12.3, 14.2.4, 14.4.3

Financial Arrangements, Owner's
2.2.1, 13.2.2, 14.1.1.4

GENERAL PROVISIONS

1

Governing Law

13.1
Guarantees (See Warranty)

Hazardous Materials and Substances
10.2.4, **10.3**
Identification of Subcontractors and Suppliers
5.2.1

Indemnification
3.17, **3.18**, 9.6.8, 9.10.2, 10.3.3, 11.3

Information and Services Required of the Owner
2.1.2, **2.2**, 2.3, 3.2.2, 3.12.10.1, 6.1.3, 6.1.4, 6.2.5,
9.6.1, 9.9.2, 9.10.3, 10.3.3, 11.2, 13.4.1, 13.4.2,
14.1.1.4, 14.1.4, 15.1.4

Initial Decision

15.2
Initial Decision Maker, Definition of
1.1.8
Initial Decision Maker, Decisions
14.2.4, 15.1.4.2, 15.2.1, 15.2.2, 15.2.3, 15.2.4, 15.2.5
Initial Decision Maker, Extent of Authority
14.2.4, 15.1.4.2, 15.2.1, 15.2.2, 15.2.3, 15.2.4, 15.2.5

Injury or Damage to Person or Property
10.2.8, 10.4
Inspections
3.1.3, 3.3.3, 3.7.1, 4.2.2, 4.2.6, 4.2.9, 9.4.2, 9.8.3,
9.9.2, 9.10.1, 12.2.1, 13.4
Instructions to Bidders
1.1.1
Instructions to the Contractor
3.2.4, 3.3.1, 3.8.1, 5.2.1, 7, 8.2.2, 12, 13.4.2

Instruments of Service, Definition of
1.1.7
Insurance
6.1.1, 7.3.4, 8.2.2, 9.3.2, 9.8.4, 9.9.1, 9.10.2, 10.2.5,
11
Insurance, Notice of Cancellation or Expiration
11.1.4, 11.2.3

Insurance, Contractor's Liability
11.1
Insurance, Effective Date of
8.2.2, 14.4.2

Insurance, Owner's Liability
11.2
Insurance, Property
10.2.5, 11.2, 11.4, 11.5
Insurance, Stored Materials
9.3.2

INSURANCE AND BONDS

11
Insurance Companies, Consent to Partial Occupancy
9.9.1
Insured loss, Adjustment and Settlement of
11.5

Intent of the Contract Documents
1.2.1, 4.2.7, 4.2.12, 4.2.13

Interest
13.5

Interpretation
1.1.8, 1.2.3, **1.4**, 4.1.1, 5.1, 6.1.2, 15.1.1
Interpretations, Written
4.2.11, 4.2.12
Judgment on Final Award
15.4.2

Labor and Materials, Equipment
1.1.3, 1.1.6, **3.4**, 3.5, 3.8.2, 3.8.3, 3.12, 3.13, 3.15.1,
5.2.1, 6.2.1, 7.3.4, 9.3.2, 9.3.3, 9.5.1.3, 9.10.2, 10.2.1,
10.2.4, 14.2.1.1, 14.2.1.2
Labor Disputes
8.3.1
Laws and Regulations
1.5, 2.3.2, 3.2.3, 3.2.4, 3.6, 3.7, 3.12.10, 3.13, 9.6.4,
9.9.1, 10.2.2, 13.1, 13.3.1, 13.4.2, 13.5, 14, 15.2.8,
15.4
Liens
2.1.2, 9.3.1, 9.3.3, 9.6.8, 9.10.2, 9.10.4, 15.2.8
Limitations, Statutes of
12.2.5, 15.1.2, 15.4.1.1
Limitations of Liability
3.2.2, 3.5, 3.12.10, 3.12.10.1, 3.17, 3.18.1, 4.2.6,
4.2.7, 6.2.2, 9.4.2, 9.6.4, 9.6.7, 9.6.8, 10.2.5, 10.3.3,
11.3, 12.2.5, 13.3.1
Limitations of Time
2.1.2, 2.2, 2.5, 3.2.2, 3.10, 3.11, 3.12.5, 3.15.1, 4.2.7,
5.2, 5.3, 5.4.1, 6.2.4, 7.3, 7.4, 8.2, 9.2, 9.3.1, 9.3.3,
9.4.1, 9.5, 9.6, 9.7, 9.8, 9.9, 9.10, 12.2, 13.4, 14, 15,
15.1.2, 15.1.3, 15.1.5

Materials, Hazardous
10.2.4, **10.3**
Materials, Labor, Equipment and
1.1.3, 1.1.6, 3.4.1, 3.5, 3.8.2, 3.8.3, 3.12, 3.13, 3.15.1,
5.2.1, 6.2.1, 7.3.4, 9.3.2, 9.3.3, 9.5.1.3, 9.10.2,
10.2.1.2, 10.2.4, 14.2.1.1, 14.2.1.2
Means, Methods, Techniques, Sequences and
Procedures of Construction
3.3.1, 3.12.10, 4.2.2, 4.2.7, 9.4.2
Mechanic's Lien
2.1.2, 9.3.1, 9.3.3, 9.6.8, 9.10.2, 9.10.4, 15.2.8

Mediation
8.3.1, 15.1.3.2, 15.2.1, 15.2.5, 15.2.6, **15.3**, 15.4.1,
15.4.1.1

Minor Changes in the Work
1.1.1, 3.4.2, 3.12.8, 4.2.8, 7.1, 7.4

MISCELLANEOUS PROVISIONS

13
Modifications, Definition of
1.1.1
Modifications to the Contract
1.1.1, 1.1.2, 2.5, 3.11, 4.1.2, 4.2.1, 5.2.3, 7, 8.3.1, 9.7,
10.3.2

Mutual Responsibility
6.2

Nonconforming Work, Acceptance of
 9.6.6, 9.9.3, **12.3**
 Nonconforming Work, Rejection and Correction of
 2.4, 2.5, 3.5, 4.2.6, 6.2.4, 9.5.1, 9.8.2, 9.9.3, 9.10.4,
 12.2
Notice
 1.6, 1.6.1, 1.6.2, 2.1.2, 2.2.2., 2.2.3, 2.2.4, 2.5, 3.2.4,
 3.3.1, 3.7.4, 3.7.5, 3.9.2, 3.12.9, 3.12.10, 5.2.1, 7.4,
 8.2.2, 9.6.8, 9.7, 9.10.1, 10.2.8, 10.3.2, 11.5, 12.2.2.1,
 13.4.1, 13.4.2, 14.1, 14.2.2, 14.4.2, 15.1.3, 15.1.5,
 15.1.6, 15.4.1
 Notice of Cancellation or Expiration of Insurance
 11.1.4, 11.2.3
Notice of Claims
 1.6.2, 2.1.2, 3.7.4, 9.6.8, 10.2.8, **15.1.3**, 15.1.5,
 15.1.6, 15.2.8, 15.3.2, 15.4.1
 Notice of Testing and Inspections
 13.4.1, 13.4.2
 Observations, Contractor's
 3.2, 3.7.4
 Occupancy
 2.3.1, 9.6.6, 9.8
 Orders, Written
 1.1.1, 2.4, 3.9.2, 7, 8.2.2, 11.5, 12.1, 12.2.2.1, 13.4.2,
 14.3.1
OWNER
2
Owner, Definition of
2.1.1
Owner, Evidence of Financial Arrangements
2.2, 13.2.2, 14.1.1.4
Owner, Information and Services Required of the
 2.1.2, **2.2**, 2.3, 3.2.2, 3.12.10, 6.1.3, 6.1.4, 6.2.5,
 9.3.2, 9.6.1, 9.6.4, 9.9.2, 9.10.3, 10.3.3, 11.2, 13.4.1,
 13.4.2, 14.1.1.4, 14.1.4, 15.1.4
 Owner's Authority
 1.5, 2.1.1, 2.3.32.4, 2.5, 3.4.2, 3.8.1, 3.12.10, 3.14.2,
 4.1.2, 4.2.4, 4.2.9, 5.2.1, 5.2.4, 5.4.1, 6.1, 6.3, 7.2.1,
 7.3.1, 8.2.2, 8.3.1, 9.3.2, 9.5.1, 9.6.4, 9.9.1, 9.10.2,
 10.3.2, 11.4, 11.5, 12.2.2, 12.3, 13.2.2, 14.3, 14.4,
 15.2.7
Owner's Insurance
11.2
 Owner's Relationship with Subcontractors
 1.1.2, 5.2, 5.3, 5.4, 9.6.4, 9.10.2, 14.2.2
Owner's Right to Carry Out the Work
2.5, 14.2.2
Owner's Right to Clean Up
6.3
Owner's Right to Perform Construction and to
Award Separate Contracts
6.1
Owner's Right to Stop the Work
2.4
 Owner's Right to Suspend the Work
 14.3
 Owner's Right to Terminate the Contract
 14.2, 14.4

Ownership and Use of Drawings, Specifications
and Other Instruments of Service
 1.1.1, 1.1.6, 1.1.7, **1.5**, 2.3.6, 3.2.2, 3.11, 3.17, 4.2.12,
 5.3
Partial Occupancy or Use
 9.6.6, **9.9**
Patching, Cutting and
3.14, 6.2.5
 Patents
 3.17
Payment, Applications for
 4.2.5, 7.3.9, 9.2, **9.3**, 9.4, 9.5, **9.6.3**, 9.7, 9.8.5, 9.10.1,
 14.2.3, 14.2.4, 14.4.3
Payment, Certificates for
 4.2.5, 4.2.9, 9.3.3, **9.4**, 9.5, 9.6.1, 9.6.6, 9.7, 9.10.1,
 9.10.3, 14.1.1.3, 14.2.4
Payment, Failure of
 9.5.1.3, **9.7**, 9.10.2, 13.5, 14.1.1.3, 14.2.1.2
 Payment, Final
 4.2.1, 4.2.9, **9.10**, 12.3, 14.2.4, 14.4.3
Payment Bond, Performance Bond and
7.3.4.4, 9.6.7, 9.10.3, **11.1.2**
Payments, Progress
 9.3, **9.6**, 9.8.5, 9.10.3, 14.2.3, **15.1.4**
PAYMENTS AND COMPLETION
9
 Payments to Subcontractors
 5.4.2, 9.5.1.3, 9.6.2, 9.6.3, 9.6.4, 9.6.7, 14.2.1.2
 PCB
 10.3.1
Performance Bond and Payment Bond
7.3.4.4, 9.6.7, 9.10.3, **11.1.2**
Permits, Fees, Notices and Compliance with Laws
 2.3.1, **3.7**, 3.13, 7.3.4.4, 10.2.2
PERSONS AND PROPERTY, PROTECTION
OF
10
 Polychlorinated Biphenyl
 10.3.1
Product Data, Definition of
3.12.2
Product Data and Samples, Shop Drawings
 3.11, **3.12**, 4.2.7
Progress and Completion
 4.2.2, **8.2**, 9.8, 9.9.1, 14.1.4, **15.1.4**
Progress Payments
 9.3, **9.6**, 9.8.5, 9.10.3, 14.2.3, **15.1.4**
Project, Definition of
1.1.4
 Project Representatives
 4.2.10
Property Insurance
 10.2.5, **11.2**
Proposal Requirements
 1.1.1
PROTECTION OF PERSONS AND PROPERTY
10

Regulations and Laws
 1.5, 2.3.2, 3.2.3, 3.6, 3.7, 3.12.10, 3.13, 9.6.4, 9.9.1, 10.2.2, 13.1, 13.3, 13.4.1, 13.4.2, 13.5, 14, 15.2.8, 15.4

Rejection of Work
 4.2.6, 12.2.1

Releases and Waivers of Liens
 9.3.1, 9.10.2

Representations
 3.2.1, 3.5, 3.12.6, 8.2.1, 9.3.3, 9.4.2, 9.5.1, 9.10.1

Representatives
 2.1.1, 3.1.1, 3.9, 4.1.1, 4.2.10, 13.2.1

Responsibility for Those Performing the Work
 3.3.2, 3.18, 4.2.2, 4.2.3, 5.3, 6.1.3, 6.2, 6.3, 9.5.1, 10

Retainage
 9.3.1, 9.6.2, 9.8.5, 9.9.1, 9.10.2, 9.10.3

Review of Contract Documents and Field Conditions by Contractor
3.2, 3.12.7, 6.1.3

Review of Contractor's Submittals by Owner and Architect
 3.10.1, 3.10.2, 3.11, 3.12, 4.2, 5.2, 6.1.3, 9.2, 9.8.2

Review of Shop Drawings, Product Data and Samples by Contractor
 3.12

Rights and Remedies
 1.1.2, 2.4, 2.5, 3.5, 3.7.4, 3.15.2, 4.2.6, 5.3, 5.4, 6.1, 6.3, 7.3.1, 8.3, 9.5.1, 9.7, 10.2.5, 10.3, 12.2.1, 12.2.2, 12.2.4, 13.3, 14, 15.4

Royalties, Patents and Copyrights
3.17

Rules and Notices for Arbitration
 15.4.1

Safety of Persons and Property
10.2, 10.4

Safety Precautions and Programs
 3.3.1, 4.2.2, 4.2.7, 5.3, 10.1, 10.2, 10.4

Samples, Definition of
3.12.3

Samples, Shop Drawings, Product Data and
 3.11, 3.12, 4.2.7

Samples at the Site, Documents and
3.11

Schedule of Values
9.2, 9.3.1

Schedules, Construction
 3.10, 3.12.1, 3.12.2, 6.1.3, 15.1.6.2

Separate Contracts and Contractors
 1.1.4, 3.12.5, 3.14.2, 4.2.4, 4.2.7, 6, 8.3.1, 12.1.2

Separate Contractors, Definition of
6.1.1

Shop Drawings, Definition of
3.12.1

Shop Drawings, Product Data and Samples
 3.11, 3.12, 4.2.7

Site, Use of
3.13, 6.1.1, 6.2.1

Site Inspections
 3.2.2, 3.3.3, 3.7.1, 3.7.4, 4.2, 9.9.2, 9.4.2, 9.10.1, 13.4

Site Visits, Architect's
 3.7.4, 4.2.2, 4.2.9, 9.4.2, 9.5.1, 9.9.2, 9.10.1, 13.4

Special Inspections and Testing
 4.2.6, 12.2.1, 13.4

Specifications, Definition of
1.1.6

Specifications
 1.1.1, 1.1.6, 1.2.2, 1.5, 3.12.10, 3.17, 4.2.14

Statute of Limitations
 15.1.2, 15.4.1.1

Stopping the Work
 2.2.2, 2.4, 9.7, 10.3, 14.1

Stored Materials
 6.2.1, 9.3.2, 10.2.1.2, 10.2.4

Subcontractor, Definition of
5.1.1

SUBCONTRACTORS
5

Subcontractors, Work by
 1.2.2, 3.3.2, 3.12.1, 3.18, 4.2.3, 5.2.3, 5.3, 5.4, 9.3.1.2, 9.6.7

Subcontractual Relations
5.3, 5.4, 9.3.1.2, 9.6, 9.10, 10.2.1, 14.1, 14.2.1

Submittals
 3.10, 3.11, 3.12, 4.2.7, 5.2.1, 5.2.3, 7.3.4, 9.2, 9.3, 9.8, 9.9.1, 9.10.2, 9.10.3

Submittal Schedule
 3.10.2, 3.12.5, 4.2.7

Subrogation, Waivers of
6.1.1, 11.3

Substances, Hazardous
10.3

Substantial Completion
 4.2.9, 8.1.1, 8.1.3, 8.2.3, 9.4.2, 9.8, 9.9.1, 9.10.3, 12.2, 15.1.2

Substantial Completion, Definition of
9.8.1

Substitution of Subcontractors
 5.2.3, 5.2.4

Substitution of Architect
 2.3.3

Substitutions of Materials
 3.4.2, 3.5, 7.3.8

Sub-subcontractor, Definition of
5.1.2

Subsurface Conditions
 3.7.4

Successors and Assigns
13.2

Superintendent
3.9, 10.2.6

Supervision and Construction Procedures
 1.2.2, 3.3, 3.4, 3.12.10, 4.2.2, 4.2.7, 6.1.3, 6.2.4, 7.1.3, 7.3.4, 8.2, 8.3.1, 9.4.2, 10, 12, 14, 15.1.4

Suppliers
1.5, 3.12.1, 4.2.4, 4.2.6, 5.2.1, 9.3, 9.4.2, 9.5.4, 9.6,
9.10.5, 14.2.1

Surety
5.4.1.2, 9.6.8, 9.8.5, 9.10.2, 9.10.3, 11.1.2, 14.2.2,
15.2.7

Surety, Consent of
9.8.5, 9.10.2, 9.10.3

Surveys
1.1.7, 2.3.4

Suspension by the Owner for Convenience **14.3**

Suspension of the Work
3.7.5, 5.4.2, 14.3
Suspension or Termination of the Contract
5.4.1.1, 14

Taxes
3.6, 3.8.2.1, 7.3.4.4

Termination by the Contractor **14.1, 15.1.7**

Termination by the Owner for Cause
5.4.1.1, **14.2**, 15.1.7

Termination by the Owner for Convenience **14.4**

Termination of the Architect
2.3.3
Termination of the Contractor Employment
14.2.2

TERMINATION OR SUSPENSION OF THE CONTRACT **14**

Tests and Inspections
3.1.3, 3.3.3, 3.7.1, 4.2.2, 4.2.6, 4.2.9, 9.4.2, 9.8.3,
9.9.2, 9.10.1, 10.3.2, 12.2.1, **13.4**

TIME **8**

Time, Delays and Extensions of
3.2.4, 3.7.4, 5.2.3, 7.2.1, 7.3.1, 7.4, **8.3**, 9.5.1, 9.7,
10.3.2, 10.4, 14.3.2, 15.1.6, 15.2.5
Time Limits
2.1.2, 2.2, 2.5, 3.2.2, 3.10, 3.11, 3.12.5, 3.15.1, 4.2,
5.2, 5.3, 5.4, 6.2.4, 7.3, 7.4, 8.2, 9.2, 9.3.1, 9.3.3,
9.4.1, 9.5, 9.6, 9.7, 9.8, 9.9, 9.10, 12.2, 13.4, 14,
15.1.2, 15.1.3, 15.4

Time Limits on Claims
3.7.4, 10.2.8, 15.1.2, 15.1.3
Title to Work
9.3.2, 9.3.3

UNCOVERING AND CORRECTION OF WORK **12**

Uncovering of Work
12.1
Unforeseen Conditions, Concealed or Unknown
3.7.4, 8.3.1, 10.3

Unit Prices
7.3.3.2, 9.1.2
Use of Documents
1.1.1, 1.5, 2.3.6, 3.12.6, 5.3

Use of Site
3.13, 6.1.1, 6.2.1

Values, Schedule of
9.2, 9.3.1
Waiver of Claims by the Architect
13.3.2

Waiver of Claims by the Contractor
9.10.5, 13.3.2, **15.1.7**
Waiver of Claims by the Owner
9.9.3, 9.10.3, 9.10.4, 12.2.2.1, 13.3.2, 14.2.4, **15.1.7**

Waiver of Consequential Damages
14.2.4, 15.1.7
Waiver of Liens
9.3, 9.10.2, 9.10.4

Waivers of Subrogation
6.1.1, **11.3**

Warranty
3.5, 4.2.9, 9.3.3, 9.8.4, 9.9.1, 9.10.2, 9.10.4, 12.2.2,
15.1.2
Weather Delays
8.3, 15.1.6.2

Work, Definition of
1.1.3
Written Consent
1.5.2, 3.4.2, 3.7.4, 3.12.8, 3.14.2, 4.1.2, 9.3.2, 9.10.3,
13.2, 13.3.2, 15.4.4.2

Written Interpretations
4.2.11, 4.2.12
Written Orders
1.1.1, 2.4, 3.9, 7, 8.2.2, 12.1, **12.2**, 13.4.2, 14.3.1

ARTICLE 1 GENERAL PROVISIONS

§ 1.1 Basic Definitions

§ 1.1.1 The Contract Documents

The Contract Documents are enumerated in the Agreement between the Owner and Contractor (hereinafter the Agreement) and consist of the Agreement, Conditions of the Contract (General, Supplementary and other Conditions), Drawings, Specifications, Addenda issued prior to execution of the Contract, other documents listed in the Agreement, and Modifications issued after execution of the Contract. A Modification is (1) a written amendment to the Contract signed by both parties, (2) a Change Order, (3) a Construction Change Directive, or (4) a written order for a minor change in the Work issued by the Architect. Unless specifically enumerated in the Agreement, the Contract Documents do not include the advertisement or invitation to bid, Instructions to Bidders, sample forms, other information furnished by the Owner in anticipation of receiving bids or proposals, the Contractor's bid or proposal, or portions of Addenda relating to bidding or proposal requirements.

§ 1.1.2 The Contract

The Contract Documents form the Contract for Construction. The Contract represents the entire and integrated agreement between the parties hereto and supersedes prior negotiations, representations, or agreements, either written or oral. The Contract may be amended or modified only by a Modification. The Contract Documents shall not be construed to create a contractual relationship of any kind (1) between the Contractor and the Architect or the Architect's consultants, (2) between the Owner and a Subcontractor or a Sub-subcontractor, (3) between the Owner and the Architect or the Architect's consultants, or (4) between any persons or entities other than the Owner and the Contractor. The Architect shall, however, be entitled to performance and enforcement of obligations under the Contract intended to facilitate performance of the Architect's duties.

§ 1.1.3 The Work

The term "Work" means the construction and services required by the Contract Documents, whether completed or partially completed, and includes all other labor, materials, equipment, and services provided or to be provided by the Contractor to fulfill the Contractor's obligations. The Work may constitute the whole or a part of the Project.

§ 1.1.4 The Project

The Project is the total construction of which the Work performed under the Contract Documents may be the whole or a part and which may include construction by the Owner and by Separate Contractors.

§ 1.1.5 The Drawings

The Drawings are the graphic and pictorial portions of the Contract Documents showing the design, location and dimensions of the Work, generally including plans, elevations, sections, details, schedules, and diagrams.

§ 1.1.6 The Specifications

The Specifications are that portion of the Contract Documents consisting of the written requirements for materials, equipment, systems, standards and workmanship for the Work, and performance of related services.

§ 1.1.7 Instruments of Service

Instruments of Service are representations, in any medium of expression now known or later developed, of the tangible and intangible creative work performed by the Architect and the Architect's consultants under their respective professional services agreements. Instruments of Service may include, without limitation, studies, surveys, models, sketches, drawings, specifications, and other similar materials.

§ 1.1.8 Initial Decision Maker

The Initial Decision Maker is the person identified in the Agreement to render initial decisions on Claims in accordance with Section 15.2. The Initial Decision Maker shall not show partiality to the Owner or Contractor and shall not be liable for results of interpretations or decisions rendered in good faith.

§ 1.2 Correlation and Intent of the Contract Documents

§ 1.2.1 The intent of the Contract Documents is to include all items necessary for the proper execution and completion of the Work by the Contractor. The Contract Documents are complementary, and what is required by one shall be as binding as if required by all; performance by the Contractor shall be required only to the extent consistent with the Contract Documents and reasonably inferable from them as being necessary to produce the indicated results.

§ 1.2.1.1 The invalidity of any provision of the Contract Documents shall not invalidate the Contract or its remaining provisions. If it is determined that any provision of the Contract Documents violates any law, or is otherwise invalid or unenforceable, then that provision shall be revised to the extent necessary to make that provision legal and enforceable. In such case the Contract Documents shall be construed, to the fullest extent permitted by law, to give effect to the parties' intentions and purposes in executing the Contract.

§ 1.2.2 Organization of the Specifications into divisions, sections and articles, and arrangement of Drawings shall not control the Contractor in dividing the Work among Subcontractors or in establishing the extent of Work to be performed by any trade.

§ 1.2.3 Unless otherwise stated in the Contract Documents, words that have well-known technical or construction industry meanings are used in the Contract Documents in accordance with such recognized meanings.

§ 1.3 Capitalization

Terms capitalized in these General Conditions include those that are (1) specifically defined, (2) the titles of numbered articles, or (3) the titles of other documents published by the American Institute of Architects.

§ 1.4 Interpretation

In the interest of brevity the Contract Documents frequently omit modifying words such as "all" and "any" and articles such as "the" and "an," but the fact that a modifier or an article is absent from one statement and appears in another is not intended to affect the interpretation of either statement.

§ 1.5 Ownership and Use of Drawings, Specifications, and Other Instruments of Service

§ 1.5.1 The Architect and the Architect's consultants shall be deemed the authors and owners of their respective Instruments of Service, including the Drawings and Specifications, and retain all common law, statutory, and other reserved rights in their Instruments of Service, including copyrights. The Contractor, Subcontractors, Sub-subcontractors, and suppliers shall not own or claim a copyright in the Instruments of Service. Submittal or distribution to meet official regulatory requirements or for other purposes in connection with the Project is not to be construed as publication in derogation of the Architect's or Architect's consultants' reserved rights.

§ 1.5.2 The Contractor, Subcontractors, Sub-subcontractors, and suppliers are authorized to use and reproduce the Instruments of Service provided to them, subject to any protocols established pursuant to Sections 1.7 and 1.8, solely and exclusively for execution of the Work. All copies made under this authorization shall bear the copyright notice, if any, shown on the Instruments of Service. The Contractor, Subcontractors, Sub-subcontractors, and suppliers may not use the Instruments of Service on other projects or for additions to the Project outside the scope of the Work without the specific written consent of the Owner, Architect, and the Architect's consultants.

§ 1.6 Notice

§ 1.6.1 Except as otherwise provided in Section 1.6.2, where the Contract Documents require one party to notify or give notice to the other party, such notice shall be provided in writing to the designated representative of the party to whom the notice is addressed and shall be deemed to have been duly served if delivered in person, by mail, by courier, or by electronic transmission if a method for electronic transmission is set forth in the Agreement.

§ 1.6.2 Notice of Claims as provided in Section 15.1.3 shall be provided in writing and shall be deemed to have been duly served only if delivered to the designated representative of the party to whom the notice is addressed by certified or registered mail, or by courier providing proof of delivery.

§ 1.7 Digital Data Use and Transmission

The parties shall agree upon protocols governing the transmission and use of Instruments of Service or any other information or documentation in digital form. The parties will use AIA Document E203™-2013, Building Information Modeling and Digital Data Exhibit, to establish the protocols for the development, use, transmission, and exchange of digital data.

§ 1.8 Building Information Models Use and Reliance

Any use of, or reliance on, all or a portion of a building information model without agreement to protocols governing the use of, and reliance on, the information contained in the model and without having those protocols set forth in AIA Document E203™-2013, Building Information Modeling and Digital Data Exhibit, and the requisite AIA Document G202™-2013, Project Building Information Modeling Protocol Form, shall be at the using or

relying party's sole risk and without liability to the other party and its contractors or consultants, the authors of, or contributors to, the building information model, and each of their agents and employees.

ARTICLE 2 OWNER

§ 2.1 General

§ 2.1.1 The Owner is the person or entity identified as such in the Agreement and is referred to throughout the Contract Documents as if singular in number. The Owner shall designate in writing a representative who shall have express authority to bind the Owner with respect to all matters requiring the Owner's approval or authorization. Except as otherwise provided in Section 4.2.1, the Architect does not have such authority. The term "Owner" means the Owner or the Owner's authorized representative.

§ 2.1.2 The Owner shall furnish to the Contractor, within fifteen days after receipt of a written request, information necessary and relevant for the Contractor to evaluate, give notice of, or enforce mechanic's lien rights. Such information shall include a correct statement of the record legal title to the property on which the Project is located, usually referred to as the site, and the Owner's interest therein.

§ 2.2 Evidence of the Owner's Financial Arrangements

§ 2.2.1 Prior to commencement of the Work and upon written request by the Contractor, the Owner shall furnish to the Contractor reasonable evidence that the Owner has made financial arrangements to fulfill the Owner's obligations under the Contract. The Contractor shall have no obligation to commence the Work until the Owner provides such evidence. If commencement of the Work is delayed under this Section 2.2.1, the Contract Time shall be extended appropriately.

§ 2.2.2 Following commencement of the Work and upon written request by the Contractor, the Owner shall furnish to the Contractor reasonable evidence that the Owner has made financial arrangements to fulfill the Owner's obligations under the Contract only if (1) the Owner fails to make payments to the Contractor as the Contract Documents require; (2) the Contractor identifies in writing a reasonable concern regarding the Owner's ability to make payment when due; or (3) a change in the Work materially changes the Contract Sum. If the Owner fails to provide such evidence, as required, within fourteen days of the Contractor's request, the Contractor may immediately stop the Work and, in that event, shall notify the Owner that the Work has stopped. However, if the request is made because a change in the Work materially changes the Contract Sum under (3) above, the Contractor may immediately stop only that portion of the Work affected by the change until reasonable evidence is provided. If the Work is stopped under this Section 2.2.2, the Contract Time shall be extended appropriately and the Contract Sum shall be increased by the amount of the Contractor's reasonable costs of shutdown, delay and start-up, plus interest as provided in the Contract Documents.

§ 2.2.3 After the Owner furnishes evidence of financial arrangements under this Section 2.2, the Owner shall not materially vary such financial arrangements without prior notice to the Contractor.

§ 2.2.4 Where the Owner has designated information furnished under this Section 2.2 as "confidential," the Contractor shall keep the information confidential and shall not disclose it to any other person. However, the Contractor may disclose "confidential" information, after seven (7) days' notice to the Owner, where disclosure is required by law, including a subpoena or other form of compulsory legal process issued by a court or governmental entity, or by court or arbitrator(s) order. The Contractor may also disclose "confidential" information to its employees, consultants, sureties, Subcontractors and their employees, Sub-subcontractors, and others who need to know the content of such information solely and exclusively for the Project and who agree to maintain the confidentiality of such information.

§ 2.3 Information and Services Required of the Owner

§ 2.3.1 Except for permits and fees that are the responsibility of the Contractor under the Contract Documents, including those required under Section 3.7.1, the Owner shall secure and pay for necessary approvals, easements, assessments and charges required for construction, use or occupancy of permanent structures or for permanent changes in existing facilities.

§ 2.3.2 The Owner shall retain an architect lawfully licensed to practice architecture, or an entity lawfully practicing architecture, in the jurisdiction where the Project is located. That person or entity is identified as the Architect in the Agreement and is referred to throughout the Contract Documents as if singular in number.

§ 2.3.3 If the employment of the Architect terminates, the Owner shall employ a successor to whom the Contractor has no reasonable objection and whose status under the Contract Documents shall be that of the Architect.

§ 2.3.4 The Owner shall furnish surveys describing physical characteristics, legal limitations and utility locations for the site of the Project, and a legal description of the site. The Contractor shall be entitled to rely on the accuracy of information furnished by the Owner but shall exercise proper precautions relating to the safe performance of the Work.

§ 2.3.5 The Owner shall furnish information or services required of the Owner by the Contract Documents with reasonable promptness. The Owner shall also furnish any other information or services under the Owner's control and relevant to the Contractor's performance of the Work with reasonable promptness after receiving the Contractor's written request for such information or services.

§ 2.3.6 Unless otherwise provided in the Contract Documents, the Owner shall furnish to the Contractor one copy of the Contract Documents for purposes of making reproductions pursuant to Section 1.5.2.

§ 2.4 Owner's Right to Stop the Work

If the Contractor fails to correct Work that is not in accordance with the requirements of the Contract Documents as required by Section 12.2 or repeatedly fails to carry out Work in accordance with the Contract Documents, the Owner may issue a written order to the Contractor to stop the Work, or any portion thereof, until the cause for such order has been eliminated; however, the right of the Owner to stop the Work shall not give rise to a duty on the part of the Owner to exercise this right for the benefit of the Contractor or any other person or entity, except to the extent required by Section 6.1.3.

§ 2.5 Owner's Right to Carry Out the Work

If the Contractor defaults or neglects to carry out the Work in accordance with the Contract Documents and fails within a ten-day period after receipt of notice from the Owner to commence and continue correction of such default or neglect with diligence and promptness, the Owner may, without prejudice to other remedies the Owner may have, correct such default or neglect. Such action by the Owner and amounts charged to the Contractor are both subject to prior approval of the Architect and the Architect may, pursuant to Section 9.5.1, withhold or nullify a Certificate for Payment in whole or in part, to the extent reasonably necessary to reimburse the Owner for the reasonable cost of correcting such deficiencies, including Owner's expenses and compensation for the Architect's additional services made necessary by such default, neglect, or failure. If current and future payments are not sufficient to cover such amounts, the Contractor shall pay the difference to the Owner. If the Contractor disagrees with the actions of the Owner or the Architect, or the amounts claimed as costs to the Owner, the Contractor may file a Claim pursuant to Article 15.

ARTICLE 3 CONTRACTOR

§ 3.1 General

§ 3.1.1 The Contractor is the person or entity identified as such in the Agreement and is referred to throughout the Contract Documents as if singular in number. The Contractor shall be lawfully licensed, if required in the jurisdiction where the Project is located. The Contractor shall designate in writing a representative who shall have express authority to bind the Contractor with respect to all matters under this Contract. The term "Contractor" means the Contractor or the Contractor's authorized representative.

§ 3.1.2 The Contractor shall perform the Work in accordance with the Contract Documents.

§ 3.1.3 The Contractor shall not be relieved of its obligations to perform the Work in accordance with the Contract Documents either by activities or duties of the Architect in the Architect's administration of the Contract, or by tests, inspections or approvals required or performed by persons or entities other than the Contractor.

§ 3.2 Review of Contract Documents and Field Conditions by Contractor

§ 3.2.1 Execution of the Contract by the Contractor is a representation that the Contractor has visited the site, become generally familiar with local conditions under which the Work is to be performed, and correlated personal observations with requirements of the Contract Documents.

§ 3.2.2 Because the Contract Documents are complementary, the Contractor shall, before starting each portion of the Work, carefully study and compare the various Contract Documents relative to that portion of the Work, as well as

the information furnished by the Owner pursuant to Section 2.3.4, shall take field measurements of any existing conditions related to that portion of the Work, and shall observe any conditions at the site affecting it. These obligations are for the purpose of facilitating coordination and construction by the Contractor and are not for the purpose of discovering errors, omissions, or inconsistencies in the Contract Documents; however, the Contractor shall promptly report to the Architect any errors, inconsistencies or omissions discovered by or made known to the Contractor as a request for information in such form as the Architect may require. It is recognized that the Contractor's review is made in the Contractor's capacity as a contractor and not as a licensed design professional, unless otherwise specifically provided in the Contract Documents.

§ 3.2.3 The Contractor is not required to ascertain that the Contract Documents are in accordance with applicable laws, statutes, ordinances, codes, rules and regulations, or lawful orders of public authorities, but the Contractor shall promptly report to the Architect any nonconformity discovered by or made known to the Contractor as a request for information in such form as the Architect may require.

§ 3.2.4 If the Contractor believes that additional cost or time is involved because of clarifications or instructions the Architect issues in response to the Contractor's notices or requests for information pursuant to Sections 3.2.2 or 3.2.3, the Contractor shall submit Claims as provided in Article 15. If the Contractor fails to perform the obligations of Sections 3.2.2 or 3.2.3, the Contractor shall pay such costs and damages to the Owner, subject to Section 15.1.7, as would have been avoided if the Contractor had performed such obligations. If the Contractor performs those obligations, the Contractor shall not be liable to the Owner or Architect for damages resulting from errors, inconsistencies or omissions in the Contract Documents, for differences between field measurements or conditions and the Contract Documents, or for nonconformities of the Contract Documents to applicable laws, statutes, ordinances, codes, rules and regulations, and lawful orders of public authorities.

§ 3.3 Supervision and Construction Procedures

§ 3.3.1 The Contractor shall supervise and direct the Work, using the Contractor's best skill and attention. The Contractor shall be solely responsible for, and have control over, construction means, methods, techniques, sequences, and procedures, and for coordinating all portions of the Work under the Contract. If the Contract Documents give specific instructions concerning construction means, methods, techniques, sequences, or procedures, the Contractor shall evaluate the jobsite safety thereof and shall be solely responsible for the jobsite safety of such means, methods, techniques, sequences, or procedures. If the Contractor determines that such means, methods, techniques, sequences or procedures may not be safe, the Contractor shall give timely written notice to the Owner and Architect, and shall propose alternative means, methods, techniques, sequences, or procedures. The Architect shall evaluate the proposed alternative solely for conformance with the design intent for the completed construction. Unless the Architect objects to the Contractor's proposed alternative, the Contractor shall perform the Work using its alternative means, methods, techniques, sequences, or procedures. The Contractor shall review any specified construction or installation procedure (including those recommended by any product manufacturer). The Contractor shall advise the Architect:

1. If the specified procedure deviates from good construction practice;
2. If following the procedure will affect any warranties; or
3. Of any objections which the Contractor may have to the procedure.

§ 3.3.2 The Contractor shall be responsible to the Owner for acts and omissions of the Contractor's employees, Subcontractors and their agents and employees, and other persons or entities performing portions of the Work for, or on behalf of, the Contractor or any of its Subcontractors.

§ 3.3.3 The Contractor shall be responsible for inspection of portions of Work already performed to determine that such portions are in proper condition to receive subsequent Work.

§ 3.3.4 The Contractor shall not be relieved of obligations to perform the work in accordance with the Contract Documents either by activities or duties of the Architect in the Architect's administration of the Contract, or by tests, inspections or approvals required or performed by persons other than the Contractor.

§ 3.4 Labor and Materials

§ 3.4.1 Unless otherwise provided in the Contract Documents, the Contractor shall provide and pay for labor, materials, equipment, tools, construction equipment and machinery, water, heat, utilities, transportation, and other facilities and services necessary for proper execution and completion of the Work, whether temporary or permanent and whether or not incorporated or to be incorporated in the Work.

§ 3.4.2 Except in the case of minor changes in the Work approved by the Architect in accordance with Section 3.12.8 or ordered by the Architect in accordance with Section 7.4, the Contractor may make substitutions only with the consent of the Owner, after evaluation by the Architect and in accordance with a Change Order or Construction Change Directive.

§ 3.4.3 The Contractor shall enforce strict discipline and good order among the Contractor's employees and other persons carrying out the Work. The Contractor shall not permit employment of unfit persons or persons not properly skilled in tasks assigned to them.

§ 3.5 Warranty

§ 3.5.1 The Contractor warrants to the Owner and Architect that materials and equipment furnished under the Contract will be of good quality and new unless otherwise required or permitted by the Contract Documents and that the Work will be free from faults and defects and in conformance with Contract Documents. The warranty will not be affected by the specification of any product or procedure, unless the Contractor objects promptly to such product or procedure and advises the Architect in writing of possible substitute products or procedures which will not affect the warranty. This warranty shall not be restricted by the limitations of any manufacturer's warranty. Work not conforming to these requirements, including substitutions not properly approved and authorized, may be considered defective. If required by the Architect, the Contractor shall furnish satisfactory evidence as to the kind and quality of materials and equipment.

§ 3.5.2 All material, equipment, or other special warranties required by the Contract Documents shall be issued in the name of the Owner, or shall be transferable to the Owner, and shall commence in accordance with Section 9.8.4.

§ 3.5.2 Inability or refusal of the Subcontractor or supplier responsible for the defective work to correct such Work shall not excuse the Contractor from performing under the warranty. If required by the Architect, the Contractor shall furnish satisfactory evidence as to the kind and quality of materials and equipment. The Contractor's warranty shall be in effect for a period of one year beginning at the date of final completion. This warranty does not limit any other rights or remedies of the Owner or Architect.

§ 3.6 Taxes

The Contractor shall pay sales, consumer, use and similar taxes for the Work provided by the Contractor that are legally enacted when bids are received or negotiations concluded, whether or not yet effective or merely scheduled to go into effect.

§ 3.7 Permits, Fees, Notices and Compliance with Laws

§ 3.7.1 Unless otherwise provided in the Contract Documents, the Contractor shall secure and pay for the building permit as well as for other permits, fees, licenses, and inspections by government agencies necessary for proper execution and completion of the Work that are customarily secured after execution of the Contract and legally required at the time bids are received or negotiations concluded.

§ 3.7.2 The Contractor shall comply with and give notices required by applicable laws, statutes, ordinances, codes, rules and regulations, and lawful orders of public authorities applicable to performance of the Work. It is not the Contractor's responsibility to ascertain that the Contract Documents are in accordance with applicable laws, statutes, ordinances, building codes and rules and regulations. However, if the Contractor observes that portions of the Contract Documents are at variance therewith, the Contractor shall promptly notify the Architect and Owner in writing, and necessary changes shall be accomplished by appropriate Modification.

§ 3.7.3 If the Contractor performs Work knowing it to be contrary to applicable laws, statutes, ordinances, codes, rules and regulations, or lawful orders of public authorities, the Contractor shall assume appropriate responsibility for such Work and shall bear any penalties assessed and the costs attributable to correction.

§ 3.7.4 Concealed or Unknown Conditions

If the Contractor encounters conditions at the site that are (1) subsurface or otherwise concealed physical conditions that differ materially from those indicated in the Contract Documents or (2) unknown physical conditions of an unusual nature that differ materially from those ordinarily found to exist and generally recognized as inherent in construction activities of the character provided for in the Contract Documents, the Contractor shall promptly provide notice to the Owner and the Architect before conditions are disturbed and in no event later than twenty one (21) days after first observance of the conditions. The Architect will promptly investigate such conditions and, if the Architect determines that they differ materially and cause an increase or decrease in the Contractor's cost of, or time required for, performance of any part of the Work, will recommend that an equitable adjustment be made in the Contract Sum or Contract Time, or both. If the Architect determines that the conditions at the site are not materially different from those indicated in the Contract Documents and that no change in the terms of the Contract is justified, the Architect shall promptly notify the Owner and Contractor, stating the reasons. If either party disputes the Architect's determination or recommendation, that party may submit a Claim as provided in Article 15.

§ 3.7.5 If, in the course of the Work, the Contractor encounters human remains or recognizes the existence of burial markers, archaeological sites or wetlands not indicated in the Contract Documents, the Contractor shall immediately suspend any operations that would affect them and shall notify the Owner and Architect. Upon receipt of such notice, the Owner shall promptly take any action necessary to obtain governmental authorization required to resume the operations. The Contractor shall continue to suspend such operations until otherwise instructed by the Owner but shall continue with all other operations that do not affect those remains or features. Requests for adjustments in the Contract Sum and Contract Time arising from the existence of such remains or features may be made as provided in Article 15.

§ 3.8 Allowances

§ 3.8.1 The Contractor shall include in the Contract Sum all allowances stated in the Contract Documents. Items covered by allowances shall be supplied for such amounts and by such persons or entities as the Owner may direct, but the Contractor shall not be required to employ persons or entities to whom the Contractor has reasonable objection.

§ 3.8.2 Unless otherwise provided in the Contract Documents,

- .1 allowances shall cover the cost to the Contractor of materials and equipment delivered at the site and all required taxes, less applicable trade discounts;
- .2 Contractor's costs for unloading and handling at the site, labor, installation costs, overhead, profit, and other expenses contemplated for stated allowance amounts shall be included in the Contract Sum but not in the allowances; and
- .3 whenever costs are more than or less than allowances, the Contract Sum shall be adjusted accordingly by Change Order. The amount of the Change Order shall reflect (1) the difference between actual costs and the allowances under Section 3.8.2.1 and (2) changes in Contractor's costs under Section 3.8.2.2.

§ 3.8.3 Materials and equipment under an allowance shall be selected by the Owner with reasonable promptness.

§ 3.9 Superintendent

§ 3.9.1 The Contractor shall employ a competent superintendent and necessary assistants who shall be in attendance at the Project site during performance of the Work. The superintendent shall represent the Contractor, and communications given to the superintendent shall be as binding as if given to the Contractor.

§ 3.9.2 The Contractor, as soon as practicable after award of the Contract, shall notify the Owner and Architect, in writing, the name and qualifications of a proposed superintendent. Within 14 days of receipt of the information, the Architect may notify the Contractor, stating whether the Owner or the Architect (1) has reasonable objection to the proposed superintendent or (2) that the Architect requires additional time for review. Failure of the Architect to provide notice within the 14-day period shall constitute notice of no reasonable objection.

§ 3.9.3 The Contractor shall not employ a proposed superintendent to whom the Owner or Architect has made reasonable and timely objection. The Contractor shall not change the superintendent without the Owner's consent, which shall not unreasonably be withheld or delayed.

§ 3.10 Contractor's Construction and Submittal Schedules

§ 3.10.1 The Contractor, promptly after being awarded the Contract, shall submit for the Owner's and Architect's information a Contractor's construction schedule for the Work. The schedule shall contain detail appropriate for the Project, including (1) the date of commencement of the Work, interim schedule milestone dates, and the date of Substantial Completion; (2) an apportionment of the Work by construction activity; and (3) the time required for completion of each portion of the Work. The schedule shall provide for the orderly progression of the Work to completion and shall not exceed time limits current under the Contract Documents. The schedule shall be revised at appropriate intervals as required by the conditions of the Work and Project. The Owner's or Architect's silence to a submitted schedule that exceeds time limits current under the Contract Documents shall not relieve the Contractor of its obligations to meet those time limits, nor shall it make the Owner or Architect liable for any of the Contractor's damages incurred as a result of increased construction time or not meeting those time limits. Similarly, failure of the Owner or the Architect to object to the Contractor's schedule showing performance in advance of such time limits shall not create or imply any rights in favor of the Contractor for performance in advance of such time limits.

§ 3.10.2 The Contractor, promptly after being awarded the Contract and thereafter as necessary to maintain a current submittal schedule, shall submit a submittal schedule for the Architect's approval. The Architect's approval shall not be unreasonably delayed or withheld. The submittal schedule shall (1) be coordinated with the Contractor's construction schedule, and (2) allow the Architect reasonable time to review submittals. If the Contractor fails to submit a submittal schedule, or fails to provide submittals in accordance with the approved submittal schedule, the Contractor shall not be entitled to any increase in Contract Sum or extension of Contract Time based on the time required for review of submittals.

§ 3.10.3 The Contractor shall perform the Work in general accordance with the most recent schedules submitted to the Owner and Architect.

§ 3.11 Documents and Samples at the Site

The Contractor shall make available, at the Project site, the Contract Documents, including Change Orders, Construction Change Directives, and other Modifications, in good order and marked currently to indicate field changes and selections made during construction, and the approved Shop Drawings, Product Data, Samples, and similar required submittals. These shall be in electronic form or paper copy, available to the Architect and Owner, and delivered to the Architect for submittal to the Owner upon completion of the Work as a record of the Work as constructed.

§ 3.11.1 Plans and sections of all concealed work, particularly concealed piping and conduit, and deviations from conditions shown on the Contract Drawings, shall be shown and dimensioned on the "Record Documents". Contractor shall develop layout drawings for all concealed work that is schematically indicated on Contract Documents.

§ 3.12 Shop Drawings, Product Data and Samples

§ 3.12.1 Shop Drawings are drawings, diagrams, schedules, and other data specially prepared for the Work by the Contractor or a Subcontractor, Sub-subcontractor, manufacturer, supplier, or distributor to illustrate some portion of the Work.

§ 3.12.2 Product Data are illustrations, standard schedules, performance charts, instructions, brochures, diagrams, and other information furnished by the Contractor to illustrate materials or equipment for some portion of the Work.

§ 3.12.3 Samples are physical examples that illustrate materials, equipment, or workmanship, and establish standards by which the Work will be judged.

§ 3.12.4 Shop Drawings, Product Data, Samples, and similar submittals are not Contract Documents. Their purpose is to demonstrate how the Contractor proposes to conform to the information given and the design concept expressed in the Contract Documents for those portions of the Work for which the Contract Documents require submittals. Review by the Architect is subject to the limitations of Section 4.2.7. Informational submittals upon which the Architect is not expected to take responsive action may be so identified in the Contract Documents. Submittals that are not required by the Contract Documents may be returned by the Architect without action.

§ 3.12.5 The Contractor shall review for compliance with the Contract Documents, approve, and submit to the Architect, Shop Drawings, Product Data, Samples, and similar submittals required by the Contract Documents, in

accordance with the submittal schedule approved by the Architect or, in the absence of an approved submittal schedule, with reasonable promptness and in such sequence as to cause no delay in the Work or in the activities of the Owner or of Separate Contractors. Submittals which are not marked as reviewed for compliance with the Contract Documents and approved by the Contractor may be returned by the Architect without action.

§ 3.12.6 By submitting Shop Drawings, Product Data, Samples, and similar submittals, the Contractor represents to the Owner and Architect that the Contractor has (1) reviewed and approved them, (2) determined and verified materials, field measurements and field construction criteria related thereto, or will do so, and (3) checked and coordinated the information contained within such submittals with the requirements of the Work and of the Contract Documents.

§ 3.12.7 The Contractor shall perform no portion of the Work for which the Contract Documents require submittal and review of Shop Drawings, Product Data, Samples, or similar submittals, until the respective submittal has been approved by the Architect.

§ 3.12.8 The Work shall be in accordance with approved submittals except that the Contractor shall not be relieved of responsibility for deviations from the requirements of the Contract Documents by the Architect's approval of Shop Drawings, Product Data, Samples, or similar submittals, unless the Contractor has specifically notified the Architect of such deviation at the time of submittal and (1) the Architect has given written approval to the specific deviation as a minor change in the Work, or (2) a Change Order or Construction Change Directive has been issued authorizing the deviation. The Contractor shall not be relieved of responsibility for errors or omissions in Shop Drawings, Product Data, Samples, or similar submittals, by the Architect's approval thereof.

§ 3.12.9 The Contractor shall direct specific attention, in writing or on resubmitted Shop Drawings, Product Data, Samples, or similar submittals, to revisions other than those requested by the Architect on previous submittals. In the absence of such notice, the Architect's approval of a resubmission shall not apply to such revisions.

§ 3.12.10 The Contractor shall not be required to provide professional services that constitute the practice of architecture or engineering unless such services are specifically required by the Contract Documents for a portion of the Work or unless the Contractor needs to provide such services in order to carry out the Contractor's responsibilities for construction means, methods, techniques, sequences, and procedures. The Contractor shall not be required to provide professional services in violation of applicable law.

§ 3.12.10.1 If professional design services or certifications by a design professional related to systems, materials, or equipment are specifically required of the Contractor by the Contract Documents, the Owner and the Architect will specify all performance and design criteria that such services must satisfy. The Contractor shall be entitled to rely upon the adequacy and accuracy of the performance and design criteria provided in the Contract Documents. The Contractor shall cause such services or certifications to be provided by an appropriately licensed design professional, whose signature and seal shall appear on all drawings, calculations, specifications, certifications, Shop Drawings, and other submittals prepared by such professional. Shop Drawings, and other submittals related to the Work, designed or certified by such professional, if prepared by others, shall bear such professional's written approval when submitted to the Architect. The Owner and the Architect shall be entitled to rely upon the adequacy and accuracy of the services, certifications, and approvals performed or provided by such design professionals, provided the Owner and Architect have specified to the Contractor the performance and design criteria that such services must satisfy. Pursuant to this Section 3.12.10, the Architect will review and approve or take other appropriate action on submittals only for the limited purpose of checking for conformance with information given and the design concept expressed in the Contract Documents.

§ 3.12.10.2 If the Contract Documents require the Contractor's design professional to certify that the Work has been performed in accordance with the design criteria, the Contractor shall furnish such certifications to the Architect at the time and in the form specified by the Architect.

§ 3.12.11 After the award of the Contract, a request by the Contractor for a substitution of materials or equipment in place of that specified in the Contract Documents will be considered only under one or more of the following conditions:

1. Required for compliance with interpretation of code requirements or insurance regulations then existing.
2. Unavailability of specified products, through no fault of the Contractor.

3. Subsequent information discloses inability of specified products to perform properly or to fit in designated space.
4. Manufacturer/fabricator refuses to certify or guarantee performance of specified product as required.
5. When it is clearly seen, in the judgment of the Architect and with the owner's approval that a substitution would be substantially to the Owner's best interests, in terms of cost, time or other considerations.

§ 3.12.12 Substitution requests shall be written, timely and accomplished by adequate technical and cost data. Requests shall include a complete description of the proposed substitution, name of the material or equipment for which it is to be substituted, drawings, cuts, performances and test date, and any other data of information necessary for a complete evaluation by the Architect.

§ 3.13 Use of Site

The Contractor shall confine operations at the site to areas permitted by applicable laws, statutes, ordinances, codes, rules and regulations, lawful orders of public authorities, and the Contract Documents and shall not unreasonably encumber the site with materials or equipment.

§ 3.14 Cutting and Patching

§ 3.14.1 The Contractor shall be responsible for cutting, fitting, or patching required to complete the Work or to make its parts fit together properly. All areas requiring cutting, fitting, or patching shall be restored to the condition existing prior to the cutting, fitting, or patching, unless otherwise required by the Contract Documents.

§ 3.14.2 The Contractor shall not damage or endanger a portion of the Work or fully or partially completed construction of the Owner or Separate Contractors by cutting, patching, or otherwise altering such construction, or by excavation. The Contractor shall not cut or otherwise alter construction by the Owner or a Separate Contractor except with written consent of the Owner and of the Separate Contractor. Consent shall not be unreasonably withheld. The Contractor shall not unreasonably withhold, from the Owner or a Separate Contractor, its consent to cutting or otherwise altering the Work.

§ 3.15 Cleaning Up

§ 3.15.1 The Contractor shall keep the premises and surrounding area free from accumulation of waste materials and rubbish caused by operations under the Contract. At completion of the Work, the Contractor shall remove waste materials, rubbish, the Contractor's tools, construction equipment, machinery, and surplus materials from and about the Project.

§ 3.15.2 If the Contractor fails to clean up as provided in the Contract Documents, the Owner may do so and the Owner shall be entitled to reimbursement from the Contractor.

§ 3.16 Access to Work

The Contractor shall provide the Owner and Architect with access to the Work in preparation and progress wherever located.

§ 3.17 Royalties, Patents and Copyrights

The Contractor shall pay all royalties and license fees. The Contractor shall defend suits or claims for infringement of copyrights and patent rights and shall hold the Owner and Architect harmless from loss on account thereof, but shall not be responsible for defense or loss when a particular design, process, or product of a particular manufacturer or manufacturers is required by the Contract Documents, or where the copyright violations are contained in Drawings, Specifications, or other documents prepared by the Owner or Architect. However, if an infringement of a copyright or patent is discovered by, or made known to, the Contractor, the Contractor shall be responsible for the loss unless the information is promptly furnished to the Architect.

§ 3.18 Indemnification

§ 3.18.1 To the fullest extent permitted by law, the Contractor waives any right on contribution against and shall indemnify and hold harmless the Owner, Architect, Architect's consultants, and agents and employees of any of them from and against claims, damages, losses, and expenses, including but not limited to attorneys' fees, arising out of or resulting from performance of the Work, provided that such claim, damage, loss, or expense is attributable to bodily injury, sickness, disease or death, or to injury to or destruction of tangible property (other than the Work itself), but only to the extent caused by the negligent acts or omissions of the Contractor, a Subcontractor, anyone directly or indirectly employed by them, or anyone for whose acts they may be liable, regardless of whether or not

such claim, damage, loss, or expense is caused in part by a party indemnified hereunder. Such obligation shall not be construed to negate, abridge, or reduce other rights or obligations of indemnity which would otherwise exist as to a party or person described in this Section 3.18.

§ 3.18.2 In claims against any person or entity indemnified under this Section 3.18 by an employee of the Contractor, a Subcontractor, anyone directly or indirectly employed by them, or anyone for whose acts they may be liable, the indemnification obligation under Section 3.18.1 shall not be limited by a limitation on amount or type of damages, compensation, or benefits payable by or for the Contractor or a Subcontractor under workers' compensation acts, disability benefit acts, or other employee benefit acts.

§ 3.18.3 "Claims, damages, losses and expenses" as these words are used in this Contract shall be construed to include, but not be limited to (1) injury of damage consequent upon the failure of or use or misuse by Contractor, its Subcontractors, agents, servants or employees, of any hoist, rigging, blocking, scaffolding, or any and all other kinds of items of equipment, whether or not the same be owned, furnished or loaned by Owner; (2) all attorneys' fees and costs incurred in defense of the claim or in bringing an action to enforce the provision of this Indemnity of any other indemnity contained in the Contract Documents; and (3) all costs, expenses, lost time, opportunity costs, et. Incurred by the party being indemnified or its employees, agents or consultants.

§ 3.19 If the Work is to be performed by trade unions, the Contractor shall make all necessary arrangements to reconcile, without delay, damage, or cost to the Owner and without recourse to the Architect or the Owner, any conflict between the Contract Documents and any agreements or regulations of any kind at any time in force among members of councils which regulate or distinguish what activities shall not be included in the work of any particular trade.

ARTICLE 4 ARCHITECT

§ 4.1 General

§ 4.1.1 The Architect is the person or entity retained by the Owner pursuant to Section 2.3.2 and identified as such in the Agreement. The term "Architect" means the Architect or Architect's authorized representation.

§ 4.1.2 Duties, responsibilities, and limitations of authority of the Architect as set forth in the Contract Documents shall not be restricted, modified, or extended without written consent of the Owner, and Architect. Consent shall not be unreasonably withheld.

§ 4.2 Administration of the Contract

§ 4.2.1 The Architect will provide administration of the Contract as described in the Contract Documents and will be an Owner's representative during construction until the date the Architect issues the final Certificate for Payment. The Architect will have authority to act on behalf of the Owner only to the extent provided in the Contract Documents.

§ 4.2.2 The Architect will visit the site at intervals appropriate to the stage of construction, or as otherwise agreed with the Owner, to become generally familiar with the progress and quality of the portion of the Work completed, and to determine in general if the Work observed is being performed in a manner indicating that the Work, when fully completed, will be in accordance with the Contract Documents. However, the Architect will not be required to make exhaustive or continuous on-site inspections to check the quality or quantity of the Work. The Architect will not have control over, charge of, or responsibility for the construction means, methods, techniques, sequences or procedures, or for the safety precautions and programs in connection with the Work, since these are solely the Contractor's rights and responsibilities under the Contract Documents.

§ 4.2.3 On the basis of the site visits, the Architect will keep the Owner reasonably informed about the progress and quality of the portion of the Work completed, and promptly report to the Owner (1) known deviations from the Contract Documents, (2) known deviations from the most recent construction schedule submitted by the Contractor, and (3) defects and deficiencies observed in the Work. The Architect will not be responsible for the Contractor's failure to perform the Work in accordance with the requirements of the Contract Documents. The Architect will not have control over or charge of, and will not be responsible for acts or omissions of, the Contractor, Subcontractors, or their agents or employees, or any other persons or entities performing portions of the Work.

§ 4.2.4 Communications

The Owner and Contractor shall include the Architect in all communications that relate to or affect the Architect's services or professional responsibilities. The Owner shall promptly notify the Architect of the substance of any direct communications between the Owner and the Contractor otherwise relating to the Project. Communications by and with the Architect's consultants shall be through the Architect. Communications by and with Subcontractors and suppliers shall be through the Contractor. Communications by and with Separate Contractors shall be through the Owner. The Contract Documents may specify other communication protocols.

§ 4.2.5 Based on the Architect's evaluations of the Contractor's Applications for Payment, the Architect will review and certify the amounts due the Contractor and will issue Certificates for Payment in such amounts.

§ 4.2.6 The Architect has authority to reject Work that does not conform to the Contract Documents. Whenever the Architect considers it necessary or advisable, the Architect will have authority to require inspection or testing of the Work in accordance with Sections 13.4.2 and 13.4.3, whether or not the Work is fabricated, installed or completed. However, neither this authority of the Architect nor a decision made in good faith either to exercise or not to exercise such authority shall give rise to a duty or responsibility of the Architect to the Contractor, Subcontractors, suppliers, their agents or employees, or other persons or entities performing portions of the Work.

§ 4.2.7 The Architect will review and approve, or take other appropriate action upon, the Contractor's submittals such as Shop Drawings, Product Data, and Samples, but only for the limited purpose of checking for conformance with information given and the design concept expressed in the Contract Documents. The Architect's action will be taken in accordance with the submittal schedule approved by the Architect or, in the absence of an approved submittal schedule, with reasonable promptness while allowing sufficient time in the Architect's professional judgment to permit adequate review. Review of such submittals is not conducted for the purpose of determining the accuracy and completeness of other details such as dimensions and quantities, or for substantiating instructions for installation or performance of equipment or systems, all of which remain the responsibility of the Contractor as required by the Contract Documents. The Architect's review of the Contractor's submittals shall not relieve the Contractor of the obligations under Sections 3.3, 3.5, and 3.12. The Architect's review shall not constitute approval of safety precautions or of any construction means, methods, techniques, sequences, or procedures. The Architect's approval of a specific item shall not indicate approval of an assembly of which the item is a component.

§ 4.2.8 The Architect will prepare Change Orders and Construction Change Directives, and may order minor changes in the Work as provided in Section 7.4. The Architect will investigate and make determinations and recommendations regarding concealed and unknown conditions as provided in Section 3.7.4.

§ 4.2.9 The Architect will conduct inspections to determine the date or dates of Substantial Completion and the date of final completion; issue Certificates of Substantial Completion pursuant to Section 9.8; receive and forward to the Owner, for the Owner's review and records, written warranties and related documents required by the Contract and assembled by the Contractor pursuant to Section 9.10; and issue a final Certificate for Payment pursuant to Section 9.10.

§ 4.2.10 If the Owner and Architect agree, the Architect will provide one or more Project representatives to assist in carrying out the Architect's responsibilities at the site. The Owner shall notify the Contractor of any change in the duties, responsibilities and limitations of authority of the Project representatives.

§ 4.2.11 The Architect will interpret and decide matters concerning performance under, and requirements of, the Contract Documents on written request of either the Owner or Contractor. The Architect's response to such requests will be made in writing within any time limits agreed upon or otherwise with reasonable promptness.

§ 4.2.12 Interpretations and decisions of the Architect will be consistent with the intent of, and reasonably inferable from, the Contract Documents and will be in writing or in the form of drawings. When making such interpretations and decisions, the Architect will endeavor to secure faithful performance by both Owner and Contractor, will not show partiality to either, and will not be liable for results of interpretations or decisions rendered in good faith.

§ 4.2.13 The Architect's decisions on matters relating to aesthetic effect will be final if reasonably inferable from the Contract Documents as being necessary to produce the intended results.

§ 4.2.14 When submitted in accordance with the Contract Documents, the Architect will review and respond to requests for information about the Contract Documents. The Architect's response to such requests will be made in writing within any time limits agreed upon or otherwise with reasonable promptness. If appropriate, the Architect will prepare and issue supplemental Drawings and Specifications in response to the requests for information. Requests for information which do not conform to the requirements of the Contract Documents, or whose answer is reasonably obtainable or inferable from the Contract Documents, may be returned by the Architect without action.

ARTICLE 5 SUBCONTRACTORS

§ 5.1 Definitions

§ 5.1.1 A Subcontractor is a person or entity who has a direct contract with the Contractor to perform a portion of the Work at the site. The term "Subcontractor" is referred to throughout the Contract Documents as if singular in number and means a Subcontractor or an authorized representative of the Subcontractor. The term "Subcontractor" does not include a Separate Contractor or the subcontractors of a Separate Contractor.

§ 5.1.2 A Sub-subcontractor is a person or entity who has a direct or indirect contract with a Subcontractor to perform a portion of the Work at the site. The term "Sub-subcontractor" is referred to throughout the Contract Documents as if singular in number and means a Sub-subcontractor or an authorized representative of the Sub-subcontractor.

§ 5.2 Award of Subcontracts and Other Contracts for Portions of the Work

§ 5.2.1 Unless otherwise stated in the Contract Documents, the Contractor, as soon as practicable after award of the Contract, shall notify the Owner and Architect of the persons or entities proposed for each principal portion of the Work, including those who are to furnish materials or equipment fabricated to a special design. Within 14 days of receipt of the information, the Architect may notify the Contractor whether the Owner or the Architect (1) has reasonable objection to any such proposed person or entity or (2) requires additional time for review. Failure of the Architect to provide notice within the fourteen (14)-day period shall constitute notice of no reasonable objection.

§ 5.2.2 The Contractor shall not contract with a proposed person or entity to whom the Owner or Architect has made reasonable and timely objection. The Contractor shall not be required to contract with anyone to whom the Contractor has made reasonable objection.

§ 5.2.3 If the Owner or Architect has reasonable objection to a person or entity proposed by the Contractor, the Contractor shall propose another to whom the Owner or Architect has no reasonable objection. If the proposed but rejected Subcontractor was reasonably capable of performing the Work, the Contract Sum and Contract Time shall be increased or decreased by the difference, if any, occasioned by such change, and an appropriate Change Order shall be issued before commencement of the substitute Subcontractor's Work. However, no increase in the Contract Sum or Contract Time shall be allowed for such change unless the Contractor has acted promptly and responsively in submitting names as required.

§ 5.2.4 The Contractor shall not substitute a Subcontractor, person, or entity for one previously selected if the Owner or Architect makes reasonable objection to such substitution.

§ 5.3 Subcontractual Relations

By appropriate written agreement, the Contractor shall require each Subcontractor, to the extent of the Work to be performed by the Subcontractor, to be bound to the Contractor by terms of the Contract Documents, and to assume toward the Contractor all the obligations and responsibilities, including the responsibility for safety of the Subcontractor's Work that the Contractor, by these Contract Documents, assumes toward the Owner and Architect. Each subcontract agreement shall preserve and protect the rights of the Owner and Architect under the Contract Documents with respect to the Work to be performed by the Subcontractor so that subcontracting thereof will not prejudice such rights, and shall allow to the Subcontractor, unless specifically provided otherwise in the subcontract agreement, the benefit of all rights, remedies, and redress against the Contractor that the Contractor, by the Contract Documents, has against the Owner. Where appropriate, the Contractor shall require each Subcontractor to enter into similar agreements with Sub-subcontractors. The Contractor shall make available to each proposed Subcontractor, prior to the execution of the subcontract agreement, copies of the Contract Documents to which the Subcontractor will be bound, and, upon written request of the Subcontractor, identify to the Subcontractor terms and conditions of the proposed subcontract agreement that may be at variance with the Contract Documents. Subcontractors will similarly make copies of applicable portions of such documents available to their respective proposed Sub-subcontractors.

§ 5.3.1 All subcontracts shall be in writing, shall be assignable by the Contractor to the Owner and shall contain the following sentence, "The Owner is an intended third-party beneficiary of this subcontract."

§ 5.4 Contingent Assignment of Subcontracts

§ 5.4.1 Each subcontract agreement for a portion of the Work is assigned by the Contractor to the Owner, provided that

- .1 assignment is effective only after termination of the Contract by the Owner for cause pursuant to Section 14.2 and only for those subcontract agreements that the Owner accepts by notifying the Subcontractor and Contractor; and
- .2 assignment is subject to the prior rights of the surety, if any, obligated under bond relating to the Contract.

§ 5.4.2 When the Owner accepts the assignment of a subcontract agreement, the Owner assumes the Contractor's rights and obligations under the subcontract.

§ 5.4.3 Upon assignment to the Owner under this Section 5.4, the Owner may further assign the subcontract to a successor contractor or other entity. If the Owner assigns the subcontract to a successor contractor or other entity, the Owner shall nevertheless remain legally responsible for all of the successor contractor's obligations under the subcontract.

ARTICLE 6 CONSTRUCTION BY OWNER OR BY SEPARATE CONTRACTORS

§ 6.1 Owner's Right to Perform Construction and to Award Separate Contracts

§ 6.1.1 The term "Separate Contractor(s)" shall mean other contractors retained by the Owner under separate agreements. The Owner reserves the right to perform construction or operations related to the Project with the Owner's own forces, and with Separate Contractors retained under Conditions of the Contract substantially similar to those of this Contract, including those provisions of the Conditions of the Contract related to insurance and waiver of subrogation.

§ 6.1.2 When separate contracts are awarded for different portions of the Project or other construction or operations on the site, the term "Contractor" in the Contract Documents in each case shall mean the Contractor who executes each separate Owner-Contractor Agreement.

§ 6.1.3 The Owner shall provide for coordination of the activities of the Owner's own forces and of each Separate Contractor with the Work of the Contractor, who shall cooperate with them. The Contractor shall participate with any Separate Contractors and the Owner in reviewing their construction schedules. The Contractor shall make any revisions to its construction schedule deemed necessary after a joint review and mutual agreement. The construction schedules shall then constitute the schedules to be used by the Contractor, Separate Contractors, and the Owner until subsequently revised.

§ 6.2 Mutual Responsibility

§ 6.2.1 The Contractor shall afford the Owner and Separate Contractors reasonable opportunity for introduction and storage of their materials and equipment and performance of their activities, and shall connect and coordinate the Contractor's construction and operations with theirs as required by the Contract Documents.

§ 6.2.2 If part of the Contractor's Work depends for proper execution or results upon construction or operations by the Owner or a Separate Contractor, the Contractor shall, prior to proceeding with that portion of the Work, promptly notify the Architect of apparent discrepancies or defects in the construction or operations by the Owner or Separate Contractor that would render it unsuitable for proper execution and results of the Contractor's Work. Failure of the Contractor to notify the Architect of apparent discrepancies or defects prior to proceeding with the Work shall constitute an acknowledgment that the Owner's or Separate Contractor's completed or partially completed construction is fit and proper to receive the Contractor's Work. The Contractor shall not be responsible for discrepancies or defects in the construction or operations by the Owner or Separate Contractor that are not apparent.

§ 6.2.3 The Contractor shall reimburse the Owner for costs the Owner incurs that are payable to a Separate Contractor because of the Contractor's delays, improperly timed activities or defective construction. The Owner

shall be responsible to the Contractor for costs the Contractor incurs because of a Separate Contractor's delays, improperly timed activities, damage to the Work or defective construction.

§ 6.2.4 The Contractor shall promptly remedy damage that the Contractor wrongfully causes to completed or partially completed construction or to property of the Owner or Separate Contractor as provided in Section 10.2.5.

§ 6.2.5 The Owner and each Separate Contractor shall have the same responsibilities for cutting and patching as are described for the Contractor in Section 3.14.

§ 6.3 Owner's Right to Clean Up

If a dispute arises among the Contractor, Separate Contractors, and the Owner as to the responsibility under their respective contracts for maintaining the premises and surrounding area free from waste materials and rubbish, the Owner may clean up and the Architect will allocate the cost among those responsible.

ARTICLE 7 CHANGES IN THE WORK

§ 7.1 General

§ 7.1.1 Changes in the Work may be accomplished after execution of the Contract, and without invalidating the Contract, by Change Order, Construction Change Directive or order for a minor change in the Work, subject to the limitations stated in this Article 7 and elsewhere in the Contract Documents.

§ 7.1.2 A Change Order shall be based upon agreement among the Owner, Contractor, and Architect. A Construction Change Directive requires agreement by the Owner and Architect and may or may not be agreed to by the Contractor. An order for a minor change in the Work may be issued by the Architect alone.

§ 7.1.3 Changes in the Work shall be performed under applicable provisions of the Contract Documents. The Contractor shall proceed promptly with changes in the Work, unless otherwise provided in the Change Order, Construction Change Directive, or order for a minor change in the Work.

§ 7.2 Change Orders

§ 7.2.1 A Change Order is a written instrument prepared by the Architect and signed by the Owner, Contractor, and Architect stating their agreement upon all of the following:

- .1 The change in the Work;
- .2 The amount of the adjustment, if any, in the Contract Sum; and
- .3 The extent of the adjustment, if any, in the Contract Time.

§ 7.3 Construction Change Directives

§ 7.3.1 A Construction Change Directive is a written order prepared by the Architect and signed by the Owner and Architect, directing a change in the Work prior to agreement on adjustment, if any, in the Contract Sum or Contract Time, or both. The Owner may by Construction Change Directive, without invalidating the Contract, order changes in the Work within the general scope of the Contract consisting of additions, deletions, or other revisions, the Contract Sum and Contract Time being adjusted accordingly.

§ 7.3.2 A Construction Change Directive shall be used in the absence of total agreement on the terms of a Change Order.

§ 7.3.3 If the Construction Change Directive provides for an adjustment to the Contract Sum, the adjustment shall be based on one of the following methods:

- .1 Mutual acceptance of a lump sum properly itemized and supported by sufficient substantiating data to permit evaluation;
- .2 Unit prices stated in the Contract Documents or subsequently agreed upon;
- .3 Cost to be determined in a manner agreed upon by the parties and a mutually acceptable fixed or percentage fee; or
- .4 As provided in Section 7.3.4.

§ 7.3.4 If the Contractor does not respond promptly or disagrees with the method for adjustment in the Contract Sum, the Architect shall determine the adjustment on the basis of reasonable expenditures and savings of those performing the Work attributable to the change, including, in case of an increase in the Contract Sum, an amount for overhead and profit as set forth in the Agreement, or if no such amount is set forth in the Agreement, a reasonable

amount. In such case, and also under Section 7.3.3.3, the Contractor shall keep and present, in such form as the Architect may prescribe, an itemized accounting together with appropriate supporting data. Unless otherwise provided in the Contract Documents, costs for the purposes of this Section 7.3.4 shall be limited to the following:

- .1 Costs of labor, including applicable payroll taxes, fringe benefits required by agreement or custom, workers' compensation insurance, and other employee costs approved by the Architect;
- .2 Costs of materials, supplies, and equipment, including cost of transportation, whether incorporated or consumed;
- .3 Rental costs of machinery and equipment, exclusive of hand tools, whether rented from the Contractor or others;
- .4 Costs of premiums for all bonds and insurance, permit fees, and sales, use, or similar taxes, directly related to the change; and
- .5 Costs of supervision and field office personnel directly attributable to the change.

§ 7.3.5 If the Contractor disagrees with the adjustment in the Contract Time, the Contractor may make a Claim in accordance with applicable provisions of Article 15.

§ 7.3.6 Upon receipt of a Construction Change Directive, the Contractor shall promptly proceed with the change in the Work involved and advise the Architect of the Contractor's agreement or disagreement with the method, if any, provided in the Construction Change Directive for determining the proposed adjustment in the Contract Sum or Contract Time.

§ 7.3.7 A Construction Change Directive signed by the Contractor indicates the Contractor's agreement therewith, including adjustment in Contract Sum and Contract Time or the method for determining them. Such agreement shall be effective immediately and shall be recorded as a Change Order.

§ 7.3.8 The amount of credit to be allowed by the Contractor to the Owner for a deletion or change that results in a net decrease in the Contract Sum shall be actual net cost as confirmed by the Architect. When both additions and credits covering related Work or substitutions are involved in a change, the allowance for overhead and profit shall be figured on the basis of net increase, if any, with respect to that change.

§ 7.3.9 Pending final determination of the total cost of a Construction Change Directive to the Owner, the Contractor may request payment for Work completed under the Construction Change Directive in Applications for Payment. The Architect will make an interim determination for purposes of monthly certification for payment for those costs and certify for payment the amount that the Architect determines, in the Architect's professional judgment, to be reasonably justified. The Architect's interim determination of cost shall adjust the Contract Sum on the same basis as a Change Order, subject to the right of either party to disagree and assert a Claim in accordance with Article 15.

§ 7.3.10 When the Owner and Contractor agree with a determination made by the Architect concerning the adjustments in the Contract Sum and Contract Time, or otherwise reach agreement upon the adjustments, such agreement shall be effective immediately and the Architect will prepare a Change Order. Change Orders may be issued for all or any part of a Construction Change Directive.

§ 7.4 Minor Changes in the Work

The Architect may order minor changes in the Work that are consistent with the intent of the Contract Documents and do not involve an adjustment in the Contract Sum or an extension of the Contract Time. The Architect's order for minor changes shall be in writing. If the Contractor believes that the proposed minor change in the Work will affect the Contract Sum or Contract Time, the Contractor shall notify the Architect and shall not proceed to implement the change in the Work. If the Contractor performs the Work set forth in the Architect's order for a minor change without prior notice to the Architect that such change will affect the Contract Sum or Contract Time, the Contractor waives any adjustment to the Contract Sum or extension of the Contract Time.

§ 7.5 AGREED OVERHEAD AND PROFIT RATES

§ 7.5.1 For any adjustments to the Contract Sum based on other than the unit process method, the Contractor agrees to charge and accept payment for his overhead and profit at the following percentages of the cost attributable to the change in the Work:

1. Five percent (5%) for Work by the Contractor not involving Subcontractors;
2. Five percent (5%) for Work by Subcontractors;

3. When both additions and credits are involved in any one change, the allowance for overhead and profit shall be figured on the basis of the net increase, if any;
4. For additional Work ordered as described above which will be executed by Subcontractors of the Contractor, it is agreed Subcontractors will be permitted to charge five percent (5%) for Work.
5. The cost to which overhead and profit stated herein is to be applied shall be determined in accordance with paragraph 7.3.6.

§ 7.6 As required by *The Criminal Code*, Section 33 E *Public Contracts* (720 ILCS 5/22D-9), any changes which authorize or necessitate an increase or decrease in either the cost of the contract by \$10,000 or more or the time of completion of the Work by thirty (30) days or more may only be made upon the written authorization of the Owner and only upon the written determination of the Owner that:

1. The circumstances necessitating the change were not reasonably foreseeable at the time the contract was signed; or
2. The change is germane to the original contract as signed; or
3. The change order is in the best interest of the Owner and is authorized by law.

ARTICLE 8 TIME

§ 8.1 Definitions

§ 8.1.1 Unless otherwise provided, Contract Time is the period of time, including authorized adjustments, allotted in the Contract Documents for Substantial Completion of the Work.

§ 8.1.2 The date of commencement of the Work is the date established in the Agreement.

§ 8.1.3 The date of Substantial Completion is the date certified by the Architect in accordance with Section 9.8.

§ 8.1.4 The term "day" as used in the Contract Documents shall mean calendar day unless otherwise specifically defined.

§ 8.2 Progress and Completion

§ 8.2.1 Time limits stated in the Contract Documents are of the essence of the Contract. By executing the Agreement, the Contractor confirms that the Contract Time is a reasonable period for performing the Work.

§ 8.2.2 The Contractor shall not knowingly, except by agreement or instruction of the Owner in writing, commence the Work prior to the effective date of insurance required to be furnished by the Contractor and Owner.

§ 8.2.3 The Contractor shall proceed expeditiously with adequate forces and shall achieve Substantial Completion within the Contract Time.

§ 8.3 Delays and Extensions of Time

§ 8.3.1 If the Contractor is delayed at any time in the commencement or progress of the Work by (1) an act or neglect of the Owner or Architect, of an employee of either, or of a Separate Contractor; (2) by changes ordered in the Work; (3) by labor disputes, fire, unusual delay in deliveries, unavoidable casualties, adverse weather conditions documented in accordance with Section 15.1.6.2, or other causes beyond the Contractor's control; (4) by delay authorized by the Owner pending mediation and binding dispute resolution; or (5) by other causes that the Contractor asserts, and the Architect determines, justify delay, then the Contract Time shall be extended for such reasonable time as the Architect may determine.

§ 8.3.2 Claims relating to time shall be made in accordance with applicable provisions of Article 15.

§ 8.3.3 The Contractor shall not be entitled to an increase in the Contract Sum as a result of any delays in the progress of the work. The Contractor's sole remedy for delay shall be an extension of time. In no event shall any delays or extensions of time be construed as cause of justification for payment of extra compensation to the Contractor. Any claims for an increase of the Contract Time shall be made in writing to the Architect within seven (7) days of the event causing the delay.

§ 8.4 If the Contractor, but for a delay not within its control, would have completed the Work prior to the time set forth in the project schedule, the Contractor shall not be entitled to any recovery of damages arising out of any event of delay which prevented such early completion of the Work.

§ 8.5 The stated milestone schedule dates for commencement of the Work, Substantial Completion of the Work and Final Completion of the Work, are material inducements to Owner in entering into this Agreement and all time limits stated in the Contract Documents are of the essence of this Agreement.

ARTICLE 9 PAYMENTS AND COMPLETION

§ 9.1 Contract Sum

§ 9.1.1 The Contract Sum is stated in the Agreement and, including authorized adjustments, is the total amount payable by the Owner to the Contractor for performance of the Work under the Contract Documents.

§ 9.1.2 If unit prices are stated in the Contract Documents or subsequently agreed upon, and if quantities originally contemplated are materially changed so that application of such unit prices to the actual quantities causes substantial inequity to the Owner or Contractor, the applicable unit prices shall be equitably adjusted.

§ 9.2 Schedule of Values

Where the Contract is based on a stipulated sum or Guaranteed Maximum Price, the Contractor shall submit a schedule of values to the Architect before the first Application for Payment, allocating the entire Contract Sum to the various portions of the Work. The schedule of values shall be prepared in the form, and supported by the data to substantiate its accuracy, required by the Architect. This schedule, unless objected to by the Architect, shall be used as a basis for reviewing the Contractor's Applications for Payment. Any changes to the schedule of values shall be submitted to the Architect and supported by such data to substantiate its accuracy as the Architect may require, and unless objected to by the Architect, shall be used as a basis for reviewing the Contractor's subsequent Applications for Payment.

§ 9.3 Applications for Payment

§ 9.3.1 At least ten (10) days before the date established for each progress payment, the Contractor shall submit to the Architect an itemized Application for Payment prepared in accordance with the schedule of values, if required under Section 9.2, for completed portions of the Work. The application shall be notarized, if required, and supported by all data substantiating the Contractor's right to payment that the Owner or Architect require, such as copies of requisitions, and releases and waivers of liens from Subcontractors and suppliers, and shall reflect retainage if provided for in the Contract Documents.

§ 9.3.1.1 As provided in Section 7.3.9, such applications may include requests for payment on account of changes in the Work that have been properly authorized by Construction Change Directives, or by interim determinations of the Architect, but not yet included in Change Orders.

§ 9.3.1.2 Applications for Payment shall not include requests for payment for portions of the Work for which the Contractor does not intend to pay a Subcontractor or supplier, unless such Work has been performed by others whom the Contractor intends to pay. However, this paragraph will not apply to routine retainage the Contractor intends to withhold from the Subcontractor pursuant to the subcontract.

§ 9.3.2 Unless otherwise provided in the Contract Documents, payments shall be made on account of materials and equipment delivered and suitably stored at the site for subsequent incorporation in the Work. If approved in advance by the Owner, payment may similarly be made for materials and equipment suitably stored off the site at a location agreed upon in writing. Payment for materials and equipment stored on or off the site shall be conditioned upon compliance by the Contractor with procedures satisfactory to the Owner to establish the Owner's title to such materials and equipment or otherwise protect the Owner's interest, and shall include the costs of applicable insurance, storage, and transportation to the site, for such materials and equipment stored off the site. The Contractor shall submit requisitions from suppliers and Subcontractors to substantiate the amounts requested on the Application for Payment for materials or equipment stored on or off site.

§ 9.3.3 The Contractor warrants that title to all Work covered by an Application for Payment will pass to the Owner no later than the time of payment. The Contractor further warrants that upon submittal of an Application for Payment all Work for which Certificates for Payment have been previously issued and payments received from the Owner shall, to the best of the Contractor's knowledge, information, and belief, be free and clear of liens, claims,

security interests, or encumbrances, in favor of the Contractor, Subcontractors, suppliers, or other persons or entities that provided labor, materials, and equipment relating to the Work. A Sworn "Contractor's Affidavit" shall be submitted with each payment request in sufficient form for the Owner to determine Contractor's right to payment and compliance with the law. Each payment request shall include properly executed waivers of lien in conformity with information set forth on a properly completed Contractor's Affidavit. In the event that the Owner is satisfied with Contractor's payment procedures, the Owner may accept partial waivers of lien of subcontractors and suppliers who were included in the immediate preceding payment. The Contractor shall submit waivers on a current basis, but the Owner may allow Subcontractors and suppliers to be not more than one payment late with their partial waivers.

§ 9.4 Certificates for Payment

§ 9.4.1 The Architect will, within seven(7) days after receipt of the Contractor's Application for Payment, either (1) issue to the Owner a Certificate for Payment in the full amount of the Application for Payment, with a copy to the Contractor; or (2) issue to the Owner a Certificate for Payment for such amount as the Architect determines is properly due, and notify the Contractor and Owner of the Architect's reasons for withholding certification in part as provided in Section 9.5.1; or (3) withhold certification of the entire Application for Payment, and notify the Contractor and Owner of the Architect's reason for withholding certification in whole as provided in Section 9.5.1.

§ 9.4.2 The issuance of a Certificate for Payment will constitute a representation by the Architect to the Owner, based on the Architect's evaluation of the Work and the data in the Application for Payment, that, to the best of the Architect's knowledge, information, and belief, the Work has progressed to the point indicated, the quality of the Work is in accordance with the Contract Documents, and that the Contractor is entitled to payment in the amount certified. The foregoing representations are subject to an evaluation of the Work for conformance with the Contract Documents upon Substantial Completion, to results of subsequent tests and inspections, to correction of minor deviations from the Contract Documents prior to completion, and to specific qualifications expressed by the Architect. However, the issuance of a Certificate for Payment will not be a representation that the Architect has (1) made exhaustive or continuous on-site inspections to check the quality or quantity of the Work; (2) reviewed construction means, methods, techniques, sequences, or procedures; (3) reviewed copies of requisitions received from Subcontractors and suppliers and other data requested by the Owner to substantiate the Contractor's right to payment; or (4) made examination to ascertain how or for what purpose the Contractor has used money previously paid on account of the Contract Sum.

§ 9.5 Decisions to Withhold Certification

§ 9.5.1 The Architect may withhold a Certificate for Payment in whole or in part, to the extent reasonably necessary to protect the Owner, if in the Architect's opinion the representations to the Owner required by Section 9.4.2 cannot be made. If the Architect is unable to certify payment in the amount of the Application, the Architect will notify the Contractor and Owner as provided in Section 9.4.1. If the Contractor and Architect cannot agree on a revised amount, the Architect will promptly issue a Certificate for Payment for the amount for which the Architect is able to make such representations to the Owner. The Architect may also withhold a Certificate for Payment or, because of subsequently discovered evidence, may nullify the whole or a part of a Certificate for Payment previously issued, to such extent as may be necessary in the Architect's opinion to protect the Owner from loss for which the Contractor is responsible, including loss resulting from acts and omissions described in Section 3.3.2, because of

- .1 defective Work not remedied;
- .2 third party claims filed or reasonable evidence indicating probable filing of such claims, unless security acceptable to the Owner is provided by the Contractor;
- .3 failure of the Contractor to make payments properly to Subcontractors or suppliers for labor, materials or equipment;
- .4 reasonable evidence that the Work cannot be completed for the unpaid balance of the Contract Sum;
- .5 damage to the Owner or a Separate Contractor;
- .6 reasonable evidence that the Work will not be completed within the Contract Time, and that the unpaid balance would not be adequate to cover actual or liquidated damages for the anticipated delay; or
- .7 repeated failure to carry out the Work in accordance with the Contract Documents.

§ 9.5.2 When either party disputes the Architect's decision regarding a Certificate for Payment under Section 9.5.1, in whole or in part, that party may submit a Claim in accordance with Article 15.

§ 9.5.3 When the reasons for withholding certification are removed, certification will be made for amounts previously withheld.

§ 9.5.4 If the Architect withholds certification for payment under Section 9.5.1.3, the Owner may, at its sole option, issue joint checks to the Contractor and to any Subcontractor or supplier to whom the Contractor failed to make payment for Work properly performed or material or equipment suitably delivered. If the Owner makes payments by joint check, the Owner shall notify the Architect and the Contractor shall reflect such payment on its next Application for Payment.

§ 9.5.5 At the election of the Owner, in addition to the Owner's remedy described in Subparagraph 9.5.1 above, a sufficient sum may be retained by the Owner as determined to be necessary for the purpose of setting aside a reasonable reserve to fully correct the loss or to protect the Owner from the loss for the items above set forth.

§ 9.5.6 If, at any time, there should be evidence of any liens or claims for which, if established, the owner will become liable and which would be chargeable to the Contractor, the Owner shall have the right to retain, out of any payment due or thereafter to become due an amount sufficient to completely indemnify the Owner against such lien or claim. Should there prove to be any such lien or claim after all payments are made, the Contractor shall repay the Owner all sums which the Owner may be compelled to pay in discharging such lien or claim, including any legal fees or other costs resulting from the lien or claim.

§ 9.6 Progress Payments

§ 9.6.1 After the Architect has issued a Certificate for Payment, the Owner shall make payment in the manner and within the time provided in the Contract Documents, and shall so notify the Architect.

§ 9.6.2 The Contractor shall pay each Subcontractor, no later than seven days after receipt of payment from the Owner, the amount to which the Subcontractor is entitled, reflecting percentages actually retained from payments to the Contractor on account of the Subcontractor's portion of the Work. The Contractor shall, by appropriate agreement with each Subcontractor, require each Subcontractor to make payments to Sub-subcontractors in a similar manner.

§ 9.6.3 The Architect will, on request, furnish to a Subcontractor, if practicable, information regarding percentages of completion or amounts applied for by the Contractor and action taken thereon by the Architect and Owner on account of portions of the Work done by such Subcontractor. Notwithstanding Article 4.2.4, the Architect/Engineer and Subcontractor may communicate directly on the matters covered by this paragraph.

§ 9.6.4 The Owner has the right to request written evidence from the Contractor that the Contractor has properly paid Subcontractors and suppliers amounts paid by the Owner to the Contractor for subcontracted Work. If the Contractor fails to furnish such evidence within seven (7) days, the Owner shall have the right to contact Subcontractors and suppliers to ascertain whether they have been properly paid. Neither the Owner nor Architect shall have an obligation to pay, or to see to the payment of money to, a Subcontractor or supplier, except as may otherwise be required by law.

§ 9.6.5 The Contractor's payments to suppliers shall be treated in a manner similar to that provided in Sections 9.6.2, 9.6.3 and 9.6.4.

§ 9.6.6 A Certificate for Payment, a progress payment, or partial or entire use or occupancy of the Project by the Owner shall not constitute acceptance of Work not in accordance with the Contract Documents.

§ 9.6.7 Unless the Contractor provides the Owner with a payment bond in the full penal sum of the Contract Sum, payments received by the Contractor for Work properly performed by Subcontractors or provided by suppliers shall be held by the Contractor for those Subcontractors or suppliers who performed Work or furnished materials, or both, under contract with the Contractor for which payment was made by the Owner. Nothing contained herein shall require money to be placed in a separate account and not commingled with money of the Contractor, create any fiduciary liability or tort liability on the part of the Contractor for breach of trust, or entitle any person or entity to an award of punitive damages against the Contractor for breach of the requirements of this provision.

§ 9.6.8 Provided the Owner has fulfilled its payment obligations under the Contract Documents, the Contractor shall defend and indemnify the Owner from all loss, liability, damage or expense, including reasonable attorney's fees and litigation expenses, arising out of any lien claim or other claim for payment by any Subcontractor or supplier of any tier. Upon receipt of notice of a lien claim or other claim for payment, the Owner shall notify the Contractor. If approved by the applicable court, when required, the Contractor may substitute a surety bond for the property against which the lien or other claim for payment has been asserted.

§ 9.8 Substantial Completion

§ 9.8.1 Substantial Completion is the stage in the progress of the Work when the Work or designated portion thereof is sufficiently complete in accordance with the Contract Documents so that the Owner can occupy or utilize the Work for its intended use.

§ 9.8.2 When the Contractor considers that the Work, or a portion thereof which the Owner agrees to accept separately, is substantially complete, the Contractor shall prepare and submit to the Architect a comprehensive list of items to be completed or corrected prior to final payment. Failure to include an item on such list does not alter the responsibility of the Contractor to complete all Work in accordance with the Contract Documents.

§ 9.8.3 Upon receipt of the Contractor's list, the Architect will make an inspection to determine whether the Work or designated portion thereof is substantially complete. If the Architect's inspection discloses any item, whether or not included on the Contractor's list, which is not sufficiently complete in accordance with the Contract Documents so that the Owner can occupy or utilize the Work or designated portion thereof for its intended use, the Contractor shall, before issuance of the Certificate of Substantial Completion, complete or correct such item upon notification by the Architect. In such case, the Contractor shall then submit a request for another inspection by the Architect to determine Substantial Completion.

§ 9.8.4 When the Work or designated portion thereof is substantially complete, the Architect will prepare a Certificate of Substantial Completion that shall establish the date of Substantial Completion; establish responsibilities of the Owner and Contractor for security, maintenance, heat, utilities, damage to the Work and insurance; and fix the time within which the Contractor shall finish all items on the list accompanying the Certificate. Warranties required by the Contract Documents shall commence on the date of Substantial Completion of the Work or designated portion thereof unless otherwise provided in the Certificate of Substantial Completion.

§ 9.8.5 The Certificate of Substantial Completion shall be submitted to the Owner and Contractor for their written acceptance of responsibilities assigned to them in the Certificate. Upon such acceptance, and consent of surety if any, the Owner shall make payment of retainage applying to the Work or designated portion thereof. Such payment shall be adjusted for Work that is incomplete or not in accordance with the requirements of the Contract Documents.

§ 9.8.6 With respect to work enumerated on the list accompanying the Certificate of Substantial Completion, the guarantee or warranty period shall start at the time of subsequent acceptance of this Work in writing by Owner.

§ 9.9 Partial Occupancy or Use

§ 9.9.1 The Owner may occupy or use any completed or partially completed portion of the Work at any stage when such portion is designated by separate agreement with the Contractor, provided such occupancy or use is consented to by the insurer and authorized by public authorities having jurisdiction over the Project. Such partial occupancy or use may commence whether or not the portion is substantially complete, provided the Owner and Contractor have accepted in writing the responsibilities assigned to each of them for payments, retainage, if any, security, maintenance, heat, utilities, damage to the Work and insurance, and have agreed in writing concerning the period for correction of the Work and commencement of warranties required by the Contract Documents. When the Contractor considers a portion substantially complete, the Contractor shall prepare and submit a list to the Architect as provided under Section 9.8.2. Consent of the Contractor to partial occupancy or use shall not be unreasonably withheld. The stage of the progress of the Work shall be determined by written agreement between the Owner and Contractor or, if no agreement is reached, by decision of the Architect.

§ 9.9.2 Immediately prior to such partial occupancy or use, the Owner, Contractor, and Architect shall jointly inspect the area to be occupied or portion of the Work to be used in order to determine and record the condition of the Work.

§ 9.9.3 Unless otherwise agreed upon, partial occupancy or use of a portion or portions of the Work shall not constitute acceptance of Work not complying with the requirements of the Contract Documents.

§ 9.10 Final Completion and Final Payment

§ 9.10.1 Upon receipt of the Contractor's notice that the Work is ready for final inspection and acceptance and upon receipt of a final Application for Payment, the Architect will promptly make such inspection. When the Architect finds the Work acceptable under the Contract Documents and the Contract fully performed, the Architect will promptly issue a final Certificate for Payment stating that to the best of the Architect's knowledge, information and belief, based upon the exercise of professional skill and care and on the basis of the Architect's on-site visits and inspections, the Work has been completed in accordance with the Contract Documents and that the entire balance found to be due the Contractor and noted in the final Certificate is due and payable. The Architect's final Certificate for Payment will constitute a further representation that conditions listed in Section 9.10.2 as precedent to the Contractor's being entitled to final payment have been fulfilled.

§ 9.10.2 Neither final payment nor any remaining retained percentage shall become due until the Contractor submits to the Architect (1) an affidavit that payrolls, bills for materials and equipment, and other indebtedness connected with the Work for which the Owner or the Owner's property might be responsible or encumbered (less amounts withheld by Owner) have been paid or otherwise satisfied, (2) a certificate evidencing that insurance required by the Contract Documents to remain in force after final payment is currently in effect, (3) a written statement that the Contractor knows of no reason that the insurance will not be renewable to cover the period required by the Contract Documents, (4) consent of surety, if any, to final payment, (5) documentation of any special warranties, such as manufacturers' warranties or specific Subcontractor warranties, and (6) if required by the Owner, other data establishing payment or satisfaction of obligations, such as receipts and releases and waivers of liens, claims, security interests, or encumbrances arising out of the Contract, to the extent and in such form as may be designated by the Owner. If a Subcontractor refuses to furnish a release or waiver required by the Owner, the Contractor may furnish a bond satisfactory to the Owner to indemnify the Owner against such lien, claim, security interest, or encumbrance. If a lien, claim, security interest, or encumbrance remains unsatisfied after payments are made, the Contractor shall refund to the Owner all money that the Owner may be compelled to pay in discharging the lien, claim, security interest, or encumbrance, including all costs and reasonable attorneys' fees.

§ 9.10.3 If, after Substantial Completion of the Work, final completion thereof is materially delayed through no fault of the Contractor or by issuance of Change Orders affecting final completion, and the Architect so confirms, the Owner shall, upon application by the Contractor and certification by the Architect, and without terminating the Contract, make payment of the balance due for that portion of the Work fully completed, corrected, and accepted. If the remaining balance for Work not fully completed or corrected is less than retainage stipulated in the Contract Documents, and if bonds have been furnished, the written consent of the surety to payment of the balance due for that portion of the Work fully completed and accepted shall be submitted by the Contractor to the Architect prior to certification of such payment. Such payment shall be made under terms and conditions governing final payment, except that it shall not constitute a waiver of Claims.

§ 9.10.4 Acceptance of final payment by the Contractor, a Subcontractor or material supplier shall constitute a waiver of claims by that payee except those previously made in writing and identified by that payee as unsettled at the time of final Application for Payment.

§ 9.10.5 Acceptance of final payment by the Contractor, a Subcontractor, or a supplier, shall constitute a waiver of claims by that payee except those previously made in writing and identified by that payee as unsettled at the time of final Application for Payment.

ARTICLE 10 PROTECTION OF PERSONS AND PROPERTY

§ 10.1 Safety Precautions and Programs

The Contractor shall be responsible for initiating, maintaining, and supervising all safety precautions and programs in connection with the performance of the Contract.

§ 10.2 Safety of Persons and Property

§ 10.2.1 The Contractor shall take reasonable precautions for safety of, and shall provide reasonable protection to prevent damage, injury, or loss to

- .1 employees on the Work and other persons who may be affected thereby;
- .2 the Work and materials and equipment to be incorporated therein, whether in storage on or off the site, under care, custody, or control of the Contractor, a Subcontractor, or a Sub-subcontractor; and
- .3 other property at the site or adjacent thereto, such as trees, shrubs, lawns, walks, pavements, roadways, structures, and utilities not designated for removal, relocation, or replacement in the course of construction.

§ 10.2.2 The Contractor shall comply with, and give notices required by applicable laws, statutes, ordinances, codes, rules and regulations, and lawful orders of public authorities, bearing on safety of persons or property or their protection from damage, injury, or loss.

§ 10.2.3 The Contractor shall implement, erect, and maintain, as required by existing conditions and performance of the Contract, reasonable safeguards for safety and protection, including posting danger signs and other warnings against hazards; promulgating safety regulations; and notifying the owners and users of adjacent sites and utilities of the safeguards.

§ 10.2.4 When use or storage of explosives or other hazardous materials or equipment, or unusual methods are necessary for execution of the Work, the Contractor shall exercise utmost care and carry on such activities under supervision of properly qualified personnel.

§ 10.2.5 The Contractor shall promptly remedy damage and loss (other than damage or loss insured under property insurance required by the Contract Documents) to property referred to in Sections 10.2.1.2 and 10.2.1.3 caused in whole or in part by the Contractor, a Subcontractor, a Sub-subcontractor, or anyone directly or indirectly employed by any of them, or by anyone for whose acts they may be liable and for which the Contractor is responsible under Sections 10.2.1.2 and 10.2.1.3. The Contractor may make a Claim for the cost to remedy the damage or loss to the extent such damage or loss is attributable to acts or omissions of the Owner or Architect or anyone directly or indirectly employed by either of them, or by anyone for whose acts either of them may be liable, and not attributable to the fault or negligence of the Contractor. The foregoing obligations of the Contractor are in addition to the Contractor's obligations under Section 3.18.

§ 10.2.6 The Contractor shall designate a responsible member of the Contractor's organization at the site whose duty shall be the prevention of accidents. This person shall be the Contractor's superintendent unless otherwise designated by the Contractor in writing to the Owner and Architect.

§ 10.2.7 The Contractor shall not permit any part of the construction or site to be loaded so as to cause damage or create an unsafe condition.

§ 10.2.8 Injury or Damage to Person or Property

If either party suffers injury or damage to person or property because of an act or omission of the other party, or of others for whose acts such party is legally responsible, written notice of the injury or damage, whether or not insured, shall be given to the other party within a reasonable time not exceeding twenty-one (21) days after discovery. The notice shall provide sufficient detail to enable the other party to investigate the matter.

§ 10.3 Hazardous Materials and Substances

§ 10.3.1 The Contractor is responsible for compliance with any requirements included in the Contract Documents regarding hazardous materials or substances. If the Contractor encounters a hazardous material or substance not addressed in the Contract Documents and if reasonable precautions will be inadequate to prevent foreseeable bodily injury or death to persons resulting from a material or substance, including but not limited to asbestos or polychlorinated biphenyl (PCB), encountered on the site by the Contractor, the Contractor shall, upon recognizing the condition, immediately stop Work in the affected area and notify the Owner and Architect of the condition in writing.

§ 10.3.2 Upon receipt of the Contractor's written notice, the Owner shall obtain the services of a licensed laboratory to verify the presence or absence of the material or substance reported by the Contractor and, in the event such material or substance is found to be present, to cause it to be rendered harmless. Unless otherwise required by the

Contract Documents, the Owner shall furnish in writing to the Contractor and Architect the names and qualifications of persons or entities who are to perform tests verifying the presence or absence of the material or substance or who are to perform the task of removal or safe containment of the material or substance. The Contractor and the Architect will promptly reply to the Owner in writing stating whether or not either has reasonable objection to the persons or entities proposed by the Owner. If either the Contractor or Architect has an objection to a person or entity proposed by the Owner, the Owner shall propose another to whom the Contractor and the Architect have no reasonable objection. When the material or substance has been rendered harmless, Work in the affected area shall resume upon written agreement of the Owner and Contractor. By Change Order, the Contract Time shall be extended appropriately and the Contract Sum shall be increased by the amount of the Contractor's reasonable additional costs of shutdown, delay, and start-up.

§ 10.3.3 To the fullest extent permitted by law, the Owner shall indemnify and hold harmless the Contractor, Subcontractors, Architect, Architect's consultants, and agents and employees of any of them from and against claims, damages, losses, and expenses, including but not limited to attorneys' fees, arising out of or resulting from performance of the Work in the affected area if in fact the material or substance presents the risk of bodily injury or death as described in Section 10.3.1 and has not been rendered harmless, provided that such claim, damage, loss, or expense is attributable to bodily injury, sickness, disease or death, or to injury to or destruction of tangible property (other than the Work itself), except to the extent that such damage, loss, or expense is due to the fault or negligence of the party seeking indemnity.

§ 10.3.4 The Owner shall not be responsible under this Section 10.3 for hazardous materials or substances the Contractor brings to the site unless such materials or substances are required by the Contract Documents. The Owner shall be responsible for hazardous materials or substances required by the Contract Documents, except to the extent of the Contractor's fault or negligence in the use and handling of such materials or substances.

§ 10.3.5 The Contractor shall reimburse the Owner for the cost and expense the Owner incurs (1) for remediation of hazardous materials or substances the Contractor brings to the site and negligently handles, or (2) where the Contractor fails to perform its obligations under Section 10.3.1, except to the extent that the cost and expense are due to the Owner's fault or negligence.

§ 10.3.6 If, without negligence on the part of the Contractor, the Contractor is held liable by a government agency for the cost of remediation of a hazardous material or substance solely by reason of performing Work as required by the Contract Documents, the Owner shall reimburse the Contractor for all cost and expense thereby incurred.

§ 10.4 Emergencies

§ 10.4.1 In an emergency affecting safety of persons or property, the Contractor shall act, at the Contractor's discretion, to prevent threatened damage, injury, or loss. Additional compensation or extension of time claimed by the Contractor on account of an emergency shall be determined as provided in Article 15 and Article 7.

ARTICLE 11 INSURANCE AND BONDS

§ 11.1 Contractor's Insurance and Bonds

§ 11.1.1 The Contractor shall purchase and maintain insurance of the types and limits of liability, containing the endorsements, and subject to the terms and conditions, as described in the Agreement or elsewhere in the Contract Documents. The Contractor shall purchase and maintain the required insurance from an insurance company or insurance companies lawfully authorized to issue insurance in the jurisdiction where the Project is located. The Owner, Architect, and Architect's consultants shall be named as additional insureds under the Contractor's commercial general liability policy or as otherwise described in the Contract Documents.

§ 11.1.2 The Contractor shall provide surety bonds of the types, for such penal sums, and subject to such terms and conditions as required by the Contract Documents. The Contractor shall purchase and maintain the required bonds from a company or companies lawfully authorized to issue surety bonds in the jurisdiction where the Project is located.

§ 11.1.3 Upon the request of any person or entity appearing to be a potential beneficiary of bonds covering payment of obligations arising under the Contract, the Contractor shall promptly furnish a copy of the bonds or shall authorize a copy to be furnished.

§ 11.1.4 Notice of Cancellation or Expiration of Contractor's Required Insurance. Within three (3) business days of the date the Contractor becomes aware of an impending or actual cancellation or expiration of any insurance required by

the Contract Documents, the Contractor shall provide notice to the Owner of such impending or actual cancellation or expiration. Upon receipt of notice from the Contractor, the Owner shall, unless the lapse in coverage arises from an act or omission of the Owner, have the right to stop the Work until the lapse in coverage has been cured by the procurement of replacement coverage by the Contractor. The furnishing of notice by the Contractor shall not relieve the Contractor of any contractual obligation to provide any required coverage.

§ 11.2 Owner's Insurance

§ 11.2.1 The Owner shall purchase and maintain insurance of the types and limits of liability, containing the endorsements, and subject to the terms and conditions, as described in the Agreement or elsewhere in the Contract Documents. The Owner shall purchase and maintain the required insurance from an insurance company or insurance companies lawfully authorized to issue insurance in the jurisdiction where the Project is located.

§ 11.2.2 Failure to Purchase Required Property Insurance. If the Owner fails to purchase and maintain the required property insurance, with all of the coverages and in the amounts described in the Agreement or elsewhere in the Contract Documents, the Owner shall inform the Contractor in writing prior to commencement of the Work. Upon receipt of notice from the Owner, the Contractor may delay commencement of the Work and may obtain insurance that will protect the interests of the Contractor, Subcontractors, and Sub-Subcontractors in the Work. When the failure to provide coverage has been cured or resolved, the Contract Sum and Contract Time shall be equitably adjusted. In the event the Owner fails to procure coverage, the Owner waives all rights against the Contractor, Subcontractors, and Sub-subcontractors to the extent the loss to the Owner would have been covered by the insurance to have been procured by the Owner. The cost of the insurance shall be charged to the Owner by a Change Order. If the Owner does not provide written notice, and the Contractor is damaged by the failure or neglect of the Owner to purchase or maintain the required insurance, the Owner shall reimburse the Contractor for all reasonable costs and damages attributable thereto.

§ 11.2.3 Notice of Cancellation or Expiration of Owner's Required Property Insurance. Within three (3) business days of the date the Owner becomes aware of an impending or actual cancellation or expiration of any property insurance required by the Contract Documents, the Owner shall provide notice to the Contractor of such impending or actual cancellation or expiration. Unless the lapse in coverage arises from an act or omission of the Contractor: (1) the Contractor, upon receipt of notice from the Owner, shall have the right to stop the Work until the lapse in coverage has been cured by the procurement of replacement coverage by either the Owner or the Contractor; (2) the Contract Time and Contract Sum shall be equitably adjusted; and (3) the Owner waives all rights against the Contractor, Subcontractors, and Sub-subcontractors to the extent any loss to the Owner would have been covered by the insurance had it not expired or been cancelled. If the Contractor purchases replacement coverage, the cost of the insurance shall be charged to the Owner by an appropriate Change Order. The furnishing of notice by the Owner shall not relieve the Owner of any contractual obligation to provide required insurance.

§ 11.3 Waivers of Subrogation

§ 11.3.1 The Owner and Contractor waive all rights against (1) each other and any of their subcontractors, sub-subcontractors, agents, and employees, each of the other; (2) the Architect and Architect's consultants; and (3) Separate Contractors, if any, and any of their subcontractors, sub-subcontractors, agents, and employees, for damages caused by fire, or other causes of loss, to the extent those losses are covered by property insurance required by the Agreement or other property insurance applicable to the Project, except such rights as they have to proceeds of such insurance. The Owner or Contractor, as appropriate, shall require similar written waivers in favor of the individuals and entities identified above from the Architect, Architect's consultants, Separate Contractors, subcontractors, and sub-subcontractors. The policies of insurance purchased and maintained by each person or entity agreeing to waive claims pursuant to this section 11.3.1 shall not prohibit this waiver of subrogation. This waiver of subrogation shall be effective as to a person or entity (1) even though that person or entity would otherwise have a duty of indemnification, contractual or otherwise, (2) even though that person or entity did not pay the insurance premium directly or indirectly, or (3) whether or not the person or entity had an insurable interest in the damaged property.

§ 11.3.2 If during the Project construction period the Owner insures properties, real or personal or both, at or adjacent to the site by property insurance under policies separate from those insuring the Project, or if after final payment property insurance is to be provided on the completed Project through a policy or policies other than those insuring the Project during the construction period, to the extent permissible by such policies, the Owner waives all rights in accordance with the terms of Section 11.3.1 for damages caused by fire or other causes of loss covered by this separate property insurance.

§ 11.4 Loss of Use, Business Interruption, and Delay in Completion Insurance

The Owner, at the Owner's option, may purchase and maintain insurance that will protect the Owner against loss of use of the Owner's property, or the inability to conduct normal operations, due to fire or other causes of loss. The Owner waives all rights of action against the Contractor and Architect for loss of use of the Owner's property, due to fire or other hazards however caused.

§11.5 Adjustment and Settlement of Insured Loss

§ 11.5.1 A loss insured under the property insurance required by the Agreement shall be adjusted by the Owner as fiduciary and made payable to the Owner as fiduciary for the insureds, as their interests may appear, subject to requirements of any applicable mortgagee clause and of Section 11.5.2. The Owner shall pay the Architect and Contractor their just shares of insurance proceeds received by the Owner, and by appropriate agreements the Architect and Contractor shall make payments to their consultants and Subcontractors in similar manner.

§ 11.5.2 Prior to settlement of an insured loss, the Owner shall notify the Contractor of the terms of the proposed settlement as well as the proposed allocation of the insurance proceeds. The Contractor shall have 14 days from receipt of notice to object to the proposed settlement or allocation of the proceeds. If the Contractor does not object, the Owner shall settle the loss and the Contractor shall be bound by the settlement and allocation. Upon receipt, the Owner shall deposit the insurance proceeds in a separate account and make the appropriate distributions. Thereafter, if no other agreement is made or the Owner does not terminate the Contract for convenience, the Owner and Contractor shall execute a Change Order for reconstruction of the damaged or destroyed Work in the amount allocated for that purpose. If the Contractor timely objects to either the terms of the proposed settlement or the allocation of the proceeds, the Owner may proceed to settle the insured loss, and any dispute between the Owner and Contractor arising out of the settlement or allocation of the proceeds shall be resolved pursuant to Article 15. Pending resolution of any dispute, the Owner may issue a Construction Change Directive for the reconstruction of the damaged or destroyed Work.

§ 11.6 MISCELLANEOUS REQUIREMENTS

§ 11.6.1 All insurance coverage shall be provided by insurance companies having security ratings no lower than A-XII by A. M. Best as of the date of the Contract. In the event coverage in place as of the date of the contract is provided by insurers with ratings lower than A-XII, Contractor can request an exception. Such request shall include evidence that such coverage is written on an Admitted basis in the State of Missouri and, in the event of an insurer insolvency, the Missouri Guarantee Fund will be available to respond to claims made under such policies.

§ 11.6.2 The required limits of liability may be met by using a Split-Limit or a Combined Single Limit basis. However, the total limit of liability shall not be less than that stated in the requirements.

§ 11.7 LAWS AND REGULATIONS

§ 11.7.1 Proposer must comply with all laws of the United States of America, State of Missouri and all ordinances and regulations of all applicable municipal authorities in the performance of the Work under this Contract. The proposer must comply with all statutes pertaining to the selection and payment of labor, including the Prevailing Wage Rate Act (Missouri Division of Labor Standards, Annual Wage Order) in affect at time of project issue.

During the performance of this Contract, the Contractor agrees as follows:

1. He will not discriminate against any employee or applicant for employment because of race, color, religion, sex, national origin ancestry and, further, that he will examine all job classifications to determine whether minority persons or women are under-utilized and will take appropriate affirmative action to rectify any such under-utilization.
2. If he hires additional employees in order to perform this Contract or any portion hereof, he will determine the availability of minorities and women in the area(s) from which he may reasonably recruit and he will hire for each job classification for which employees are hired in such a way that minorities and women are not under-utilized.
3. In all solicitations or advertisements for employees placed by him or on his behalf, he will state that all applicants will be afforded equal opportunity without discrimination because of race, color, religion, sex, national origin or ancestry.

§ 11.8 ASSIGNMENT

§ 11.8.1 Neither party to the Contract shall assign the Contract or sublet it as a whole without the written consent of the other nor shall the Contractor assign any monies due to or to become due to him hereunder, without the previous written consent of the Owner.

§ 11.9 NO WAIVER OF LEGAL RIGHTS

§ 11.9.1 The Owner shall not be precluded nor stopped from any measurements, estimate or certificate made either before or after the completion and acceptance of the Work and payment therefore from showing the true amount and character of the Work performed, any measurement, estimate, or certificate is untrue or incorrectly made, or that the Work or materials do not conform in fact to the Construction Documents. The Owner shall not be precluded or estopped, notwithstanding any such measurement, estimate, certificate and payment in accordance therewith from recovering from the Contractor and his Sureties such damage as it may sustain by reason of his failure to comply with the terms of the Contract.

§ 11.9.2 Neither the acceptance by the Owner nor any representative of the Owner, nor any payment for or acceptance of the whole or any part of the Work nor any extension of time, nor any possession taken by the Owner shall operate as a waiver of any portion of the Contract or of any power herein reserved, or any right to damage therein provided. A waiver of breach of the Contract shall not be held to be a waiver of any other or subsequent breach.

§ 11.10

§ 11.10.1 Whenever any Contractor is declared by the Owner to be in default under the Contract or fails to comply with the Contract, the Surety and the contractor are each responsible to make full payment to the Owner for any and all extra work incurred by the Architect/Engineer, Site Engineer or others as a result of the contractor's default and to pay to the Owner all costs and expenses resulting from the default and the curing and correction thereof plus all attorneys' fees, court costs and expenses incurred by the Owner as a result of the Contractor's default and also in the protection and prosecution of the Owner's rights under the Contract.

ARTICLE 12 UNCOVERING AND CORRECTION OF WORK

§ 12.1 Uncovering of Work

§ 12.1.1 If a portion of the Work is covered contrary to the Architect's request or to requirements specifically expressed in the Contract Documents, it must, if requested in writing by the Architect, be uncovered for the Architect's examination and be replaced at the Contractor's expense without change in the Contract Time.

§ 12.1.2 If a portion of the Work has been covered that the Architect has not specifically requested to examine prior to its being covered, the Architect may request to see such Work and it shall be uncovered by the Contractor. If such Work is in accordance with the Contract Documents, the Contractor shall be entitled to an equitable adjustment to the Contract Sum and Contract Time as may be appropriate. If such Work is not in accordance with the Contract Documents, the costs of uncovering the Work, and the cost of correction, shall be at the Contractor's expense.

§ 12.2 Correction of Work

§ 12.2.1 Before Substantial Completion

The Contractor shall promptly correct Work rejected by the Architect or failing to conform to the requirements of the Contract Documents, discovered before Substantial Completion and whether or not fabricated, installed or completed. Costs of correcting such rejected Work, including additional testing and inspections, the cost of uncovering and replacement, and compensation for the Architect's services and expenses made necessary thereby, shall be at the Contractor's expense.

§ 12.2.2 After Substantial Completion

§ 12.2.2.1 In addition to the Contractor's obligations under Section 3.5, if, within one year after the date of Substantial Completion of the Work or designated portion thereof or after the date for commencement of warranties established under Section 9.9.1, or by terms of any applicable special warranty required by the Contract Documents, any of the Work is found to be not in accordance with the requirements of the Contract Documents, the Contractor shall correct it promptly after receipt of written notice from the Owner to do so, unless the Owner has previously given the Contractor a written acceptance of such condition. The Owner shall give such notice promptly after discovery of the condition. During the one-year period for correction of Work, if the Owner fails to notify the Contractor and give the Contractor an opportunity to make the correction, the Owner waives the rights to require correction by the Contractor and to make a claim for breach of warranty. If the Contractor fails to correct nonconforming Work within a reasonable time during that period after receipt of notice from the Owner or Architect, the Owner may correct it in accordance with Section 2.5.

§ 12.2.2.2 The one-year period for correction of Work shall be extended with respect to portions of Work first performed after Substantial Completion by the period of time between Substantial Completion and the actual completion of that portion of the Work.

§ 12.2.2.3 The one-year period for correction of Work shall not be extended by corrective Work performed by the Contractor pursuant to this Section 12.2.

§ 12.2.3 The Contractor shall remove from the site portions of the Work that are not in accordance with the requirements of the Contract Documents and are neither corrected by the Contractor nor accepted by the Owner.

§ 12.2.4 The Contractor shall bear the cost of correcting destroyed or damaged construction of the Owner or Separate Contractors, whether completed or partially completed, caused by the Contractor's correction or removal of Work that is not in accordance with the requirements of the Contract Documents.

§ 12.2.5 Nothing contained in this Section 12.2 shall be construed to establish a period of limitation with respect to other obligations the Contractor has under the Contract Documents. Establishment of the one-year period for correction of Work as described in Section 12.2.2 relates only to the specific obligation of the Contractor to correct the Work, and has no relationship to the time within which the obligation to comply with the Contract Documents may be sought to be enforced, nor to the time within which proceedings may be commenced to establish the Contractor's liability with respect to the Contractor's obligations other than specifically to correct the Work.

§ 12.3 Acceptance of Nonconforming Work

If the Owner prefers to accept Work that is not in accordance with the requirements of the Contract Documents, the Owner may do so instead of requiring its removal and correction, in which case the Contract Sum will be reduced as appropriate and equitable. Such adjustment shall be effected whether or not final payment has been made.

ARTICLE 13 MISCELLANEOUS PROVISIONS

§ 13.1 Governing Law

The Contract shall be governed by the law of the place where the Project is located, excluding that jurisdiction's choice of law rules. If the parties have selected arbitration as the method of binding dispute resolution, the Federal Arbitration Act shall govern Section 15.4.

§ 13.2 Successors and Assigns

§ 13.2.1 The Owner and Contractor respectively bind themselves, their partners, successors, assigns, and legal representatives to covenants, agreements, and obligations contained in the Contract Documents. Except as provided in Section 13.2.2, neither party to the Contract shall assign the Contract as a whole without written consent of the other. If either party attempts to make an assignment without such consent, that party shall nevertheless remain legally responsible for all obligations under the Contract. Notwithstanding any of the provisions of this paragraph, however, the Owner may assign the Contract to an affiliated entity without the consent of the Contractor.

§ 13.2.2 The Owner may, without consent of the Contractor, assign the Contract to a lender providing construction financing for the Project, if the lender assumes the Owner's rights and obligations under the Contract Documents. The Contractor shall execute all consents reasonably required to facilitate the assignment.

§ 13.3 Rights and Remedies

§ 13.3.1 Duties and obligations imposed by the Contract Documents and rights and remedies available thereunder shall be in addition to and not a limitation of duties, obligations, rights, and remedies otherwise imposed or available by law.

§ 13.3.2 No action or failure to act by the Owner, Architect, or Contractor shall constitute a waiver of a right or duty afforded them under the Contract, nor shall such action or failure to act constitute approval of or acquiescence in a breach thereunder, except as may be specifically agreed upon in writing.

§ 13.4 Tests and Inspections

§ 13.4.1 Tests, inspections, and approvals of portions of the Work shall be made as required by the Contract Documents and by applicable laws, statutes, ordinances, codes, rules, and regulations or lawful orders of public authorities. Unless otherwise provided, the Contractor shall make arrangements for such tests, inspections, and

approvals with an independent testing laboratory or entity acceptable to the Owner, or with the appropriate public authority, and shall bear all related costs of tests, inspections, and approvals. The Contractor shall give the Architect timely notice of when and where tests and inspections are to be made so that the Architect may be present for such procedures. The Owner shall bear costs of tests, inspections, or approvals that do not become requirements until after bids are received or negotiations concluded. The Owner shall directly arrange and pay for tests, inspections, or approvals where building codes or applicable laws or regulations so require.

§ 13.4.2 If the Architect, Owner, or public authorities having jurisdiction determine that portions of the Work require additional testing, inspection, or approval not included under Section 13.4.1, the Architect will, upon written authorization from the Owner, instruct the Contractor to make arrangements for such additional testing, inspection, or approval, by an entity acceptable to the Owner, and the Contractor shall give timely notice to the Architect of when and where tests and inspections are to be made so that the Architect may be present for such procedures. Such costs, except as provided in Section 13.4.3, shall be at the Owner's expense.

§ 13.4.3 If procedures for testing, inspection, or approval under Sections 13.4.1 and 13.4.2 reveal failure of the portions of the Work to comply with requirements established by the Contract Documents, all costs made necessary by such failure, including those of repeated procedures and compensation for the Architect's services and expenses, shall be at the Contractor's expense.

§ 13.4.4 Required certificates of testing, inspection, or approval shall, unless otherwise required by the Contract Documents, be secured by the Contractor and promptly delivered to the Architect.

§ 13.4.5 If the Architect is to observe tests, inspections, or approvals required by the Contract Documents, the Architect will do so promptly and, where practicable, at the normal place of testing.

§ 13.4.6 Tests or inspections conducted pursuant to the Contract Documents shall be made promptly to avoid unreasonable delay in the Work.

§ 13.5 Interest

Payments due and unpaid under the Contract Documents shall bear interest from the date payment is due at the rate the parties agree upon in writing or, in the absence thereof, at the legal rate prevailing from time to time at the place where the Project is located.

§ 13.6 The Contractor shall compensate the Architect for time expended by the Architect for contract administration time, at the Architect's hourly rate of the individual providing the service for the following:

1. After two (2) reviews of shop drawings/submittals per item.
2. Any office or field time spent after the second Punch list (excluding project closeout procedures).
3. Any office or field time spent should Project closeout extend more than thirty (30) days beyond Substantial Completion.
4. Any office or field time necessitated by the Contractor's failure to achieve the scheduled date of Substantial Completion.

The funds paid to the Architect will be deducted by the Owner from the amounts due the Contractor for these additional services by change order and paid directly to the Architect.

ARTICLE 14 TERMINATION OR SUSPENSION OF THE CONTRACT

§ 14.1 Termination by the Contractor

§ 14.1.1 The Contractor may terminate the Contract if the Work is stopped for a period of thirty (30) consecutive days through no act or fault of the Contractor, a Subcontractor, a Sub-subcontractor, their agents or employees, or any other persons or entities performing portions of the Work, for any of the following reasons:

- .1 Issuance of an order of a court or other public authority having jurisdiction that requires all Work to be stopped;
- .2 An act of government, such as a declaration of national emergency, that requires all Work to be stopped;
- .3 Because the Architect has not issued a Certificate for Payment and has not notified the Contractor of the reason for withholding certification as provided in Section 9.4.1, or because the Owner has not made payment on a Certificate for Payment within the time stated in the Contract Documents; or

.4 The Owner has failed to furnish to the Contractor reasonable evidence as required by Section 2.2.

§ 14.1.2 The Contractor may terminate the Contract if, through no act or fault of the Contractor, a Subcontractor, a Sub-subcontractor, their agents or employees, or any other persons or entities performing portions of the Work, repeated suspensions, delays, or interruptions of the entire Work by the Owner as described in Section 14.3, constitute in the aggregate more than 100 percent of the total number of days scheduled for completion, or 120 days in any 365-day period, whichever is less.

§ 14.1.3 If one of the reasons described in Section 14.1.1 or 14.1.2 exists, the Contractor may, upon seven (7) days' written notice to the Owner and Architect, terminate the Contract and recover from the Owner payment for Work executed, as well as reasonable overhead and profit on Work not executed, and costs incurred by reason of such termination.

§ 14.1.4 If the Work is stopped for a period of sixty (60) consecutive days through no act or fault of the Contractor, a Subcontractor, a Sub-subcontractor, or their agents or employees or any other persons or entities performing portions of the Work because the Owner has repeatedly failed to fulfill the Owner's obligations under the Contract Documents with respect to matters important to the progress of the Work, the Contractor may, upon seven (7) additional days' written notice to the Owner and the Architect, terminate the Contract and recover from the Owner as provided in Section 14.1.3.

§ 14.2 Termination by the Owner for Cause

§ 14.2.1 The Owner may terminate the Contract if the Contractor

- .1 repeatedly refuses or fails to supply enough properly skilled workers or proper materials;
- .2 fails to make payment to Subcontractors or suppliers in accordance with the respective agreements between the Contractor and the Subcontractors or suppliers;
- .3 repeatedly disregards applicable laws, statutes, ordinances, codes, rules and regulations, or lawful orders of a public authority; or
- .4 otherwise is guilty of substantial breach of a provision of the Contract Documents.

§ 14.2.2 When any of the reasons described in Section 14.2.1 exist, and upon certification by the Architect that sufficient cause exists to justify such action, the Owner may, without prejudice to any other rights or remedies of the Owner and after giving the Contractor and the Contractor's surety, if any, seven (7) days' written notice, terminate employment of the Contractor and may, subject to any prior rights of the surety:

- .1 Exclude the Contractor from the site and take possession of all materials, equipment, tools, and construction equipment and machinery thereon owned by the Contractor;
- .2 Accept assignment of subcontracts pursuant to Section 5.4; and
- .3 Finish the Work by whatever reasonable method the Owner may deem expedient. Upon written request of the Contractor, the Owner shall furnish to the Contractor a detailed accounting of the costs incurred by the Owner in finishing the Work.

§ 14.2.3 When the Owner terminates the Contract for one of the reasons stated in Section 14.2.1, the Contractor shall not be entitled to receive further payment until the Work is finished.

§ 14.2.4 If the unpaid balance of the Contract Sum exceeds costs of finishing the Work, including compensation for the Architect's services and expenses made necessary thereby, and other damages incurred by the Owner and not expressly waived, such excess shall be paid to the Contractor. If such costs and damages exceed the unpaid balance, the Contractor shall pay the difference to the Owner. The amount to be paid to the Contractor or Owner, as the case may be, shall be certified by the Initial Decision Maker, upon application, and this obligation for payment shall survive termination of the Contract.

§ 14.3 Suspension by the Owner for Convenience

§ 14.3.1 The Owner may, without cause, order the Contractor in writing to suspend, delay or interrupt the Work, in whole or in part for such period of time as the Owner may determine.

§ 14.3.2 If suspension, delay or interruption by the Owner constitutes more than twenty percent (20%) of the total number of days scheduled for completion, the Contract Sum and Contract Time shall be adjusted for increases in the cost and time caused by suspension, delay, or interruption under Section 14.3.1. Adjustment of the Contract Sum shall not include profit. No adjustment shall be made to the extent

- .1 that performance is, was, or would have been, so suspended, delayed, or interrupted, by another cause for which the Contractor is responsible; or
- .2 that an equitable adjustment is made or denied under another provision of the Contract.

§ 14.3.3 Any adjustment made in the Contract Sum pursuant to paragraph 14.3.2 shall be subject to the provisions of Article 7.3.6. Overhead shall be allowed to the extent of one-half the percentages set forth in Article 7.5.

§ 14.4 Termination by the Owner for Convenience

§ 14.4.1 The Owner may, at any time, terminate the Contract for the Owner's convenience and without cause.

§ 14.4.2 Upon receipt of notice from the Owner of such termination for the Owner's convenience, the Contractor shall

- .1 cease operations as directed by the Owner in the notice;
- .2 take actions necessary, or that the Owner may direct, for the protection and preservation of the Work; and
- .3 except for Work directed to be performed prior to the effective date of termination stated in the notice, terminate all existing subcontracts and purchase orders and enter into no further subcontracts and purchase orders.

§ 14.4.3 In case of such termination for the Owner's convenience, the Owner shall pay the Contractor for Work properly executed; costs incurred by reason of the termination, including costs attributable to termination of Subcontracts; and the termination fee, if any, set forth in the Agreement. Overhead shall be based on one half of the percentages given in paragraph 7.5.

ARTICLE 15 CLAIMS AND DISPUTES

§ 15.1 Claims

§ 15.1.1 Definition

A Claim is a demand or assertion by one of the parties seeking, as a matter of right, payment of money, a change in the Contract Time, or other relief with respect to the terms of the Contract. The term "Claim" also includes other disputes and matters in question between the Owner and Contractor arising out of or relating to the Contract. The responsibility to substantiate Claims shall rest with the party making the Claim. This Section 15.1.1 does not require the Owner to file a Claim in order to impose liquidated damages in accordance with the Contract Documents.

§ 15.1.2 Time Limits on Claims

The Owner and Contractor shall commence all Claims and causes of action against the other and arising out of or related to the Contract, whether in contract, tort, breach of warranty or otherwise, in accordance with the requirements of the binding dispute resolution method selected in the Agreement and within the period specified by applicable law, but in any case not more than 10 years after the date of Substantial Completion of the Work. The Owner and Contractor waive all Claims and causes of action not commenced in accordance with this Section 15.1.2.

§ 15.1.3 Notice of Claims

§ 15.1.3.1 Claims by either the Owner or Contractor, where the condition giving rise to the Claim is first discovered prior to expiration of the period for correction of the Work set forth in Section 12.2.2, shall be initiated by written notice to the other party and to the Initial Decision Maker with a copy sent to the Architect, if the Architect is not serving as the Initial Decision Maker. Claims by either party under this Section 15.1.3.1 shall be initiated within twenty-one (21) days after occurrence of the event giving rise to such Claim or within twenty-one (21) days after the claimant first recognizes the condition giving rise to the Claim, whichever is later.

§ 15.1.3.2 Claims by either the Owner or Contractor, where the condition giving rise to the Claim is first discovered after expiration of the period for correction of the Work set forth in Section 12.2.2, shall be initiated by notice to the other party. In such event, no decision by the Initial Decision Maker is required.

§ 15.1.4 Continuing Contract Performance

§ 15.1.4.1 Pending final resolution of a Claim, except as otherwise agreed in writing or as provided in Section 9.7 and Article 14, the Contractor shall proceed diligently with performance of the Contract and the Owner shall continue to make payments in accordance with the Contract Documents.

§ 15.1.4.2 The Contract Sum and Contract Time shall be adjusted in accordance with the Initial Decision Maker's decision, subject to the right of either party to proceed in accordance with this Article 15. The Architect will issue Certificates for Payment in accordance with the decision of the Initial Decision Maker.

§ 15.1.5 Claims for Additional Cost

If the Contractor wishes to make a Claim for an increase in the Contract Sum, written notice as provided in Section 15.1.3 shall be given before proceeding to execute the portion of the Work that is the subject of the Claim. Prior notice is not required for Claims relating to an emergency endangering life or property arising under Section 10.4.

§ 15.1.6 Claims for Additional Time

§ 15.1.6.1 If the Contractor wishes to make a Claim for an increase in the Contract Time, written notice as provided in Section 15.1.3 shall be given. The Contractor's Claim shall include an estimate of cost and of probable effect of delay on progress of the Work. In the case of a continuing delay, only one Claim is necessary.

§ 15.1.6.2 If adverse weather conditions are the basis for a Claim for additional time, such Claim shall be documented by data substantiating that weather conditions were abnormal for the period of time, could not have been reasonably anticipated, and had an adverse effect on the scheduled construction.

§ 15.1.6.3 The criteria on which the term "weather delays" shall be based on the normal average amount of precipitation received in the project areas, as recorded over a period of the last five (5) years by NOAA, National Climatic Data Center. Any extension of time due to unusually severe weather must be requested by the Contractor on the basis of documented records of the actual precipitation for a minimum period of three (3) months, compared with the normal average for the area. The criteria shall also include the number of excessive precipitation days over the same period and whether or not the Contractor's force worked on said days or any stage of construction was affected.

§ 15.1.5.4 Delay caused by any Subcontractor shall be the responsibility of the Contractor. The Contractor shall therefore, ensure that all Subcontractors shall at all times provide sufficient personnel, equipment and materials to substantially complete the Work in the time specified herein.

§ 15.1.5.5 Where a delay occurs which is beyond the Contractor's control, the Contractor has an affirmative duty to mitigate the effect of that delay on the progress of the Work. An extension of the Substantial Completion date will not be granted to the extent that the Contractor breaches said duty to mitigate.

§ 15.1.5.6 Additionally, the Contractor shall not be entitled to payment or compensation for any alleged damages, costs or expenses whatsoever, including but not limited to costs of acceleration, arising in any manner because of hindrance or delay, from any cause whatsoever, whether such hindrances or delay be reasonable, foreseeable, avoidable or unavoidable.

§ 15.1.5.7 The Contractor shall not be entitled to recover from the Owner, and hereby waives all rights which it or its Subcontractors or any other person may otherwise have to recover, any costs, expenses and damages of any nature which it or its Subcontractors or any other person, may suffer by reason of delay in the performance of the Work or any portion thereof for any reason, the extension of Contract Time granted herein being the Contractor's sole and exclusive remedy.

§ 15.1.7 Waiver of Claims for Consequential Damages

The Contractor and Owner waive Claims against each other for consequential damages arising out of or relating to this Contract. This mutual waiver includes

- .1 damages incurred by the Owner for rental expenses, for losses of use, income, profit, financing, business and reputation, and for loss of management or employee productivity or of the services of such persons; and
- .2 damages incurred by the Contractor for principal office expenses including the compensation of personnel stationed there, for losses of financing, business and reputation, and for loss of profit, except anticipated profit arising directly from the Work.

This mutual waiver is applicable, without limitation, to all consequential damages due to either party's termination in accordance with Article 14. Nothing contained in this Section 15.1.7 shall be deemed to preclude assessment of liquidated damages, when applicable, in accordance with the requirements of the Contract Documents.

§ 15.2 Initial Decision

§ 15.2.1 Claims, excluding those where the condition giving rise to the Claim is first discovered after expiration of the period for correction of the Work set forth in Section 12.2.2 or arising under Sections 10.3, 10.4, and 11.5, shall be referred to the Initial Decision Maker for initial decision. The Architect will serve as the Initial Decision Maker, unless otherwise indicated in the Agreement. Except for those Claims excluded by this Section 15.2.1, an initial decision shall be required as a condition precedent to mediation of any Claim. If an initial decision has not been rendered within 30 days after the Claim has been referred to the Initial Decision Maker, the party asserting the Claim may demand mediation and binding dispute resolution without a decision having been rendered. Unless the Initial Decision Maker and all affected parties agree, the Initial Decision Maker will not decide disputes between the Contractor and persons or entities other than the Owner.

§ 15.2.2 The Initial Decision Maker will review Claims and within ten (10) days of the receipt of a Claim take one or more of the following actions: (1) request additional supporting data from the claimant or a response with supporting data from the other party, (2) reject the Claim in whole or in part, (3) approve the Claim, (4) suggest a compromise, or (5) advise the parties that the Initial Decision Maker is unable to resolve the Claim if the Initial Decision Maker lacks sufficient information to evaluate the merits of the Claim or if the Initial Decision Maker concludes that, in the Initial Decision Maker's sole discretion, it would be inappropriate for the Initial Decision Maker to resolve the Claim.

§ 15.2.3 In evaluating Claims, the Initial Decision Maker may, but shall not be obligated to, consult with or seek information from either party or from persons with special knowledge or expertise who may assist the Initial Decision Maker in rendering a decision. The Initial Decision Maker may request the Owner to authorize retention of such persons at the Owner's expense.

§ 15.2.4 If the Initial Decision Maker requests a party to provide a response to a Claim or to furnish additional supporting data, such party shall respond, within ten (10) days after receipt of the request, and shall either (1) provide a response on the requested supporting data, (2) advise the Initial Decision Maker when the response or supporting data will be furnished, or (3) advise the Initial Decision Maker that no supporting data will be furnished. Upon receipt of the response or supporting data, if any, the Initial Decision Maker will either reject or approve the Claim in whole or in part.

§ 15.2.5 The Initial Decision Maker will render an initial decision approving or rejecting the Claim, or indicating that the Initial Decision Maker is unable to resolve the Claim. This initial decision shall (1) be in writing; (2) state the reasons therefor; and (3) notify the parties and the Architect, if the Architect is not serving as the Initial Decision Maker, of any change in the Contract Sum or Contract Time or both. The initial decision shall be final and binding on the parties but subject to mediation and, if the parties fail to resolve their dispute through mediation, to binding dispute resolution.

§ 15.2.5.1 When the Architect is acting as the Initial Decision Maker, interpretations and decisions of the Architect shall be consistent with the intent of and reasonably inferable from the Contract Documents. In no event, shall the Architect be liable for results of interpretation or decisions rendered in good faith. The Architect's decisions on matters relating to aesthetic effects shall be final if consistent with the intent expressed in the Contract Documents.

§ 15.2.6 Either party may file for mediation of an initial decision at any time, subject to the terms of Section 15.2.6.1.

§ 15.2.6.1 Either party may, within thirty (30) days from the date of receipt of an initial decision, demand in writing that the other party file for mediation. If such a demand is made and the party receiving the demand fails to file for mediation within thirty (30) days after receipt thereof, then both parties waive their rights to mediate or pursue binding dispute resolution proceedings with respect to the initial decision.

§ 15.2.7 In the event of a Claim against the Contractor, the Owner may, but is not obligated to, notify the surety, if any, of the nature and amount of the Claim. If the Claim relates to a possibility of a Contractor's default, the Owner may, but is not obligated to, notify the surety and request the surety's assistance in resolving the controversy.

§ 15.2.8 If a Claim relates to or is the subject of a mechanic's lien, the party asserting such Claim may proceed in accordance with applicable law to comply with the lien notice or filing deadlines.

§ 15.3 Mediation

§ 15.3.1 Claims, disputes, or other matters in controversy arising out of or related to the Contract, except those waived as provided for in Sections 9.10.4, 9.10.5, and 15.1.7, shall be subject to mediation as a condition precedent to binding dispute resolution.

§ 15.3.2 The parties shall endeavor to resolve their Claims by mediation which, unless the parties mutually agree otherwise, shall be administered by the American Arbitration Association in accordance with its Construction Industry Mediation Procedures in effect on the date of the Agreement. A request for mediation shall be made in writing, delivered to the other party to the Contract, and filed with the person or entity administering the mediation. The request may be made concurrently with the filing of binding dispute resolution proceedings but, in such event, mediation shall proceed in advance of binding dispute resolution proceedings, which shall be stayed pending mediation for a period of 60 days from the date of filing, unless stayed for a longer period by agreement of the parties or court order. If an arbitration is stayed pursuant to this Section 15.3.2, the parties may nonetheless proceed to the selection of the arbitrator(s) and agree upon a schedule for later proceedings.

§ 15.3.3 Either party may, within 30 days from the date that mediation has been concluded without resolution of the dispute or 60 days after mediation has been demanded without resolution of the dispute, demand in writing that the other party file for binding dispute resolution. If such a demand is made and the party receiving the demand fails to file for binding dispute resolution within 60 days after receipt thereof, then both parties waive their rights to binding dispute resolution proceedings with respect to the initial decision.

§ 15.3.4 The parties shall share the mediator's fee and any filing fees equally. The mediation shall be held in the place where the Project is located, unless another location is mutually agreed upon. Agreements reached in mediation shall be enforceable as settlement agreements in any court having jurisdiction thereof.

§ 15.4 Arbitration

§ 15.4.1 If the parties have selected arbitration as the method for binding dispute resolution in the Agreement, any Claim subject to, but not resolved by, mediation shall be subject to arbitration which, unless the parties mutually agree otherwise, shall be administered by the American Arbitration Association in accordance with its Construction Industry Arbitration Rules in effect on the date of the Agreement. The Arbitration shall be conducted in the place where the Project is located, unless another location is mutually agreed upon. A demand for arbitration shall be made in writing, delivered to the other party to the Contract, and filed with the person or entity administering the arbitration. The party filing a notice of demand for arbitration must assert in the demand all Claims then known to that party on which arbitration is permitted to be demanded.

§ 15.4.1.1 A demand for arbitration shall be made no earlier than concurrently with the filing of a request for mediation, but in no event shall it be made after the date when the institution of legal or equitable proceedings based on the Claim would be barred by the applicable statute of limitations. For statute of limitations purposes, receipt of a written demand for arbitration by the person or entity administering the arbitration shall constitute the institution of legal or equitable proceedings based on the Claim.

§ 15.4.2 The award rendered by the arbitrator or arbitrators shall be final, and judgment may be entered upon it in accordance with applicable law in any court having jurisdiction thereof.

§ 15.4.3 The foregoing agreement to arbitrate and other agreements to arbitrate with an additional person or entity duly consented to by parties to the Agreement, shall be specifically enforceable under applicable law in any court having jurisdiction thereof.

§ 15.4.4 Consolidation or Joinder

§ 15.4.4.1 Subject to the rules of the American Arbitration Association or other applicable arbitration rules, either party may consolidate an arbitration conducted under this Agreement with any other arbitration to which it is a party provided that (1) the arbitration agreement governing the other arbitration permits consolidation, (2) the arbitrations to be consolidated substantially involve common questions of law or fact, and (3) the arbitrations employ materially similar procedural rules and methods for selecting arbitrator(s).

§ 15.4.4.2 Subject to the rules of the American Arbitration Association or other applicable arbitration rules, either party may include by joinder persons or entities substantially involved in a common question of law or fact whose

presence is required if complete relief is to be accorded in arbitration, provided that the party sought to be joined consents in writing to such joinder. Consent to arbitration involving an additional person or entity shall not constitute consent to arbitration of any claim, dispute or other matter in question not described in the written consent.

§ 15.4.4.3 The Owner and Contractor grant to any person or entity made a party to an arbitration conducted under this Section 15.4, whether by joinder or consolidation, the same rights of joinder and consolidation as those of the Owner and Contractor under this Agreement.

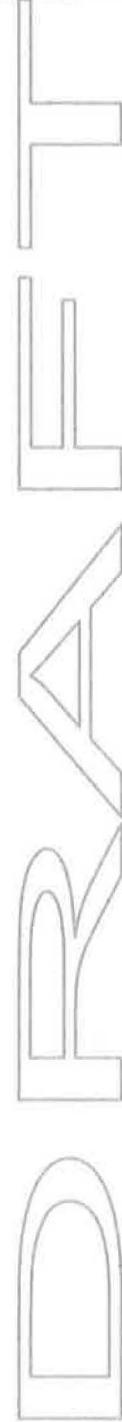

FGMARCHITECTS

DESIGN TEAM HOURLY RATE TABLE

Where the fee arrangements are to be on an hourly basis, the rates shall be those that prevail at the time services are rendered. Current rates are as follows:

FGM Architects Inc.

| | |
|-----------------------|-------|
| Principal | \$300 |
| Arch IV | 260 |
| Arch III | 220 |
| Arch II | 180 |
| Arch I | 140 |
| Interior Designer IV | 240 |
| Interior Designer III | 200 |
| Interior Designer II | 160 |
| Interior Designer I | 120 |
| Project Administrator | 135 |

*Hourly rates shown above are effective as of November 2023, and are subject to adjustment on 01 November each year.

Dermody & Associates, LLC

| | |
|---------------------|-------|
| Landscape Architect | \$125 |
| Administrative | 100 |

Middleton Consulting & Contracting (SDVOB)

| | |
|--------------------------|---------------|
| | <u>\$/Hr.</u> |
| Principal | 195 |
| Senior Cost Estimator | 165 |
| Cost Estimator 2 | 135 |
| Cost Estimator 1 | 105 |
| Assistant Cost Estimator | 65 |

Thouvenot, Wade and Moerchen, Inc.

| SCHEDULE OF HOURLY FEES | |
|---|----------|
| Survey Crew (3 person crew) | \$264.00 |
| Survey Crew (2 person crew) | \$206.00 |
| Survey Crew (2 person crew w/Robotics or GPS) | \$217.00 |
| Survey Crew (1 person w/Robotics or GPS) | \$156.00 |
| Survey Crew (2 person w/3D Scanner) | \$279.00 |
| Survey Crew (1 person w/3D Scanner) | \$216.00 |
| Surveyor V | \$188.00 |
| Surveyor IV | \$172.00 |
| Surveyor III | \$154.00 |
| Surveyor II | \$136.00 |
| Surveyor I | \$118.00 |
| 3D Scanning Technician | \$167.00 |
| Technician VI | \$119.00 |
| Technician V | \$111.00 |
| Technician IV | \$102.00 |
| Technician III | \$95.00 |
| Technician II | \$92.00 |
| Technician I | \$85.00 |
| Jr Technician | \$61.00 |

Bacon Farmer Workman Engineering & Testing, Inc.

2024 Professional Services Fee Schedule

| | |
|--|------------------|
| Principal | \$ 215.00 / hour |
| Transportation/Civil/Structural | |
| Landscape Architect | \$ 135.00 / hour |
| Project Manager/Engineer - Senior | \$ 185.00 / hour |
| Project Manager/Engineer II | \$ 168.00 / hour |
| Project Manager/Engineer I | \$ 148.00 / hour |
| Project Engineer II | \$ 145.00 / hour |
| Project Engineer I | \$ 130.00 / hour |
| Staff Engineer | \$ 118.00 / hour |
| Design Manager | \$ 125.00 / hour |
| Designer - Senior | \$ 123.00 / hour |
| Designer II | \$ 120.00 / hour |
| Designer I | \$ 108.00 / hour |
| Drafter II | \$ 78.00 / hour |
| Drafter I | \$ 72.00 / hour |
| Landscape Designer | \$ 100.00 / hour |
| Senior Consultant | \$ 340.00 / hour |
| Project Administrator | \$ 100.00 / hour |
| Inspection - Air & Surface Transportation | |
| Resident Engineer | \$ 185.00 / hour |
| Assistant Resident Engineer | \$ 158.00 / hour |
| Phase III Technician | \$ 118.00 / hour |
| Inspection - Vertical Buildings | |
| Project Manager/Engineer - Senior | \$ 185.00 / hour |
| Inspector II/Chief | \$ 135.00 / hour |
| Inspector I/Senior Resident | \$ 110.00 / hour |
| Construction Administrator | \$ 118.00 / hour |
| Technician I (Special Inspections are \$90.00/hour) | \$ 69.00 / hour |
| Geotechnical & Laboratory Services | |
| Geologist II | \$ 135.00 / hour |
| Geologist I | \$ 93.00 / hour |
| Lab Manager | \$ 100.00 / hour |
| Technician I | \$ 69.00 / hour |
| Driller | \$ 95.00 / hour |
| Reproduction - Fees | |
| Full Size Copies - 24" x 36" | \$ 1.00 / sheet |
| 11" x 17" Copies | \$ 0.75 / sheet |
| Full Size Mylars | \$ 10.00 / sheet |
| Sepias | \$ 3.00 / each |
| Color Copies - 24" x 36" | \$ 10.00 / each |
| Color Copies - 18" x 24" | \$ 8.00 / each |
| Color Copies - 11" x 17" | \$ 2.00 / each |
| Color Copies - 8.5" x 11" | \$ 1.00 / each |
| Xerox Copies | \$ 0.10 / each |
| Aerial Photographs | \$ 60.00 / each |
| Scan Sheets | \$ 3.50 / sheet |

| | |
|--|------------------|
| Biological & Environmental Services | |
| Environmental Manager | \$ 185.00 / hour |
| Environmental Engineer | \$ 120.00 / hour |
| Environmental Scientist / Technician | \$ 90.00 / hour |
| GIS Specialist | \$ 115.00 / hour |
| Wetland Specialist | \$ 155.00 / hour |
| Asbestos Inspector / Lead Risk Assessor | \$ 115.00 / hour |
| Historical Preservation Specialist | \$ 155.00 / hour |
| Geospatial & Survey Services | |
| Project Manager/Engineer - Senior | \$ 185.00 / hour |
| Project Manager/Engineer I | \$ 148.00 / hour |
| Survey - Manager | \$ 130.00 / hour |
| Survey - Field Lead | \$ 100.00 / hour |
| Survey - Surveyor | \$ 85.00 / hour |
| GPS Crew - 1 Person | \$ 170.00 / hour |
| GPS Crew - 2 Person | \$ 255.00 / hour |
| Survey Crew - 2 Person | \$ 185.00 / hour |
| Survey Crew - 3 Person | \$ 270.00 / hour |
| Robotic Crew - 1 Person | \$ 155.00 / hour |
| Robotic Crew - 2 Person | \$ 240.00 / hour |
| Construction Staking | \$ 220.00 / hour |
| LiDar Instrumentation | \$ 7,500 / day |
| LiDar Operator | \$ 145.00 / hour |
| FAA Certified Remote Pilot and Drone | \$ 235.00 / hour |
| Data Processing & Extraction | \$ 145.00 / hour |
| 3D Scanner | \$ 1,400 / day |
| 3D Scanner Operator | \$ 100.00 / hour |
| Other Professional Services | |
| Senior Safety Professional | \$ 185.00 / hour |
| Safety Professional | \$ 160.00 / hour |
| Grants Coordinator | \$ 155.00 / hour |
| Administration | \$ 145.00 / hour |
| Clerical | \$ 75.00 / hour |
| Litigation Support | 2 x Std Rate |
| Miscellaneous | |
| Lodging | Actual Cost |
| Photographs | \$ 1.00 / each |
| Mileage | \$ 0.75 / mile |
| Meals per diem | \$ 51.00 / day |
| ATV | \$ 125.00 / day |

- Schedule is effective January 1, 2024 thru December 31, 2024
- Pre-approved overtime is 1.5 times rate. Sundays and Holidays at premium rates.

2024 Professional Services Rate and Reimbursement Schedule

| | |
|--|--|
| Principal | \$215.00 / hour |
| Project Manager | \$185.00 / hour |
| Electrical Design Manager | \$185.00 / hour |
| Project Engineer II | \$130.00 / hour |
| Project Engineer I | \$125.00 / hour |
| Engineer | \$115.00 / hour |
| Construction Administrator | \$118.00 / hour |
| Senior Designer | \$116.00 / hour |
| Designer | \$102.00 / hour |
| Senior Drafter | \$81.00 / hour |
| Drafter | \$76.00 / hour |
| Litigation Support | 2 x Standard Rate |
| Clerical | \$75.00 / hour |
| Reimbursable Expenses | |
| Mileage | \$0.75 / mile |
| Preapproved Travel Expenses (including mileage, lodging and meals) | Reimbursement of furnished receipts |
| Reproduction of Plans | \$0.30/FT. ² Inhouse or Printer's Invoiced Amount Plus 15% |
| Reproduction of Specifications | \$0.30/Sheet Inhouse or Printer's Invoiced Amount Plus 15% |
| Courier Service (UPS, FEDEX, Etc.) | Invoiced Amount Plus 15% |
| Plan Sets for Building Code Review | Application Fee Plus 15% and Reproduction Costs |
| Scanned Documents | \$3.50/Sheet |

1. Schedule is effective January 1, 2024 thru December 31, 2024
2. Pre-approved overtime is 1.5 times rate. Sundays and Holidays at premium rates.

Intertek PSI, Inc.

PSI, INC. • SCHEDULE OF SERVICES AND FEES EFFECTIVE JANUARY 1, 2023

Engineering

Engineering and technical services for preliminary reconnaissance, boring layout, delayed water levels, backfilling of borings, evaluation, field supervision, analysis, recommendations, reporting and consultation.

| | | |
|--|----------|----------|
| Chief Engineer/Scientist | Per Hour | \$195.00 |
| Principal Consultant | Per Hour | \$175.00 |
| Regional Engineer/Scientist/Manager | Per Hour | \$135.00 |
| Senior Engineer/Scientist/Department Manager | Per Hour | \$125.00 |
| Project Engineer/Scientist/Manager | Per Hour | \$115.00 |
| Clerical | Per Hour | \$65.00 |

Laboratory Testing

| | | |
|--|------|----------|
| Moisture content tests | Each | \$12.00 |
| Density determinations (undisturbed sample) | Each | \$65.00 |
| Unconfined compression w/moisture and density (undisturbed sample) | Each | \$95.00 |
| Percent passing #200 sieve | Each | \$72.00 |
| Grain size analysis (washed) | Each | \$85.00 |
| Grain size analysis (unwashed) | Each | \$75.00 |
| Atterberg limits determination | Each | \$110.00 |
| Hydrometer | Each | \$218.00 |
| Moisture density relationship of soils | | |
| ASTM-D 698 (Standard) | Each | \$176.00 |
| ASTM-D 1557 (Modified) | Each | \$207.00 |
| California bearing ratio, w/o moisture-density relationship | Each | \$350.00 |

Drilling

| | | |
|---|------------|------------|
| Stand-by | Per Hour | \$305.00 |
| Set up charge for rock coring/mud rotary | Per Boring | \$275.00 |
| Rock coring, NX-sized (0 to 25 feet) | Per Foot | \$49.00 |
| Rock coring, NX-sized (25 to 50 feet) | Per Foot | \$57.00 |
| Rock coring, NX-sized (50 to 75 feet) | Per Foot | \$65.50 |
| Cost of special equipment or permits for moving drilling equipment about the site | | Cost + 20% |

Remarks

The following apply unless otherwise addressed in the proposal:

- Unit prices are in effect until the end of the year from the date of this proposal and are subject to change without notice thereafter.
- Overtime rates will be applicable for services performed in excess of 8 hours per day Monday through Friday and for all hours worked on Saturdays, Sundays and holidays. The overtime rate will be 1.7 times the applicable hourly rate.
- All rates are billed on a portal-to-portal basis.
- Transportation and per diem will be charged at the applicable rate.
- Rates involving mileage (including transportation, mobilization, and trip charges) are subject to change based upon increases in the national average gasoline price.
- A minimum charge of 4 hours applies to field testing and observation services.
- A project setup charge of a minimum of 2 hours applies to all projects.
- Drilling and field service rates are based on OSHA Level D personnel protection.
- For sites where drilling is to occur that are not readily accessible to a truck-mounted drill rig, rates for rig mobility equipment, site clearing, and crew stand-by time will be charged as applicable.
- Services and fees not listed on this schedule may be quoted on request.

MEMORANDUM

Meeting Date: 09 January 2024
Meeting Time: Afternoon
Meeting Location: Via phone
Project Name: Washington Fire Department (WFD) – New Satellite Fire Facility
Project Number: M4-0633
Participants: Tim Frankenberg, Josh Mandell
Meeting Purpose: Notice of Request for Proposal, Preliminary Project Parameters Clarification

ITEMS DISCUSSED

- To supersede the original project solicitation: City / WFD have determined that proposed new satellite fire facility should be in the range of 9,000 to 12,000 gross square feet
- Project all-in budget (to include hard-cost of construction, site development (excluding some rough grading by subdivision developer), FFE, and all consulting costs (see below for additional related information) should be in the range of \$4.5 to 5.2 MM
- City would – at this time – desire for FGMA as Prime Consultant to propose all consulting and services required to affect the subject project including but not necessarily limited to –
 - Geotechnical Engineering and sub-Surface Drilling
 - Environmental Investigation
 - Land Surveying
 - Title Commitments Research
 - Testing and Special Inspections
 - and so forth

FGMA will gather proposals for all per Owner request, but may prefer to have City / WFD contract for some or all of these scopes directly. To be discussed further.

- FGMA is to have the prime proposal (Master Contract) submitted by 26 January for review and consideration by City of Washington / WFD.

FOR THE FIRM

Joshua N. Mandell | Principal-in-Charge

cc:

Enclosure(s):



November 17, 2023

Dear Consultant:

The City of Washington is requesting the services of a consulting engineering firm to perform the described professional services for the project included on the attached list. If your firm would like to be considered for these consulting services, you may express your interest by responding to the appropriate office, which is indicated on the attachments. Limit your letter of interest to no more than (5) five pages. This letter should include any information which might help us in the selection process, such as the persons or team you would assign to each project, the backgrounds of those individuals and other projects your company has recently completed or are now active. Please include specific work for fire or EMS stations within the last five years. It is required that your firm's Statement of Qualifications (RSMo 8.285 through 8.291) be submitted with your firm's Letter of Interest. The statement of qualification is not included in the total page count limit.

We request all letters be received by 12:00 p.m., CDT on Friday, December 8, 2023 at the office of:

Washington City Clerk
Washington City Hall
405 Jefferson Street
Washington, MO 63090

The RFQ shall be delivered in a sealed envelope with "RFQ – Fire Station" clearly marked on outside.

Sincerely,

A handwritten signature in black ink, appearing to read "Darren Lamb".

Darren Lamb, AICP
City Administrator

| City of Washington Project: Fire Station | |
|---|--|
| Location: | To be determined |
| Proposed Improvement: | Design, and provide construction oversight services, for a new fire station approximately 10,000 sq. ft. with an anticipated life of at least 35 years. The building is anticipated to be three drive through bays and administrative area with living quarters, work out facility and meeting/training area. Design concepts from the existing buildings are to be utilized based on experience and operation. The building design is anticipated to utilize technologies that assist in carcinogenic exposure reduction. It is strongly desired the ease of maintenance is considered as the design moves forward. |
| Approximate Construction Cost: | \$3,400,000 |
| Consultant Services Required: | <i>The engineering responsibilities may include but are not limited to the following: The preparation of Preliminary Plans and Contract plans. Design services may include, surveying, geotechnical investigations, subsurface utility exploration, contract documents, assisting with the bidding process, construction support/construction inspection, prevailing wage oversight, utility coordination/permits, and structural plan development.</i> |
| Other Comments: | Submit 6 copies of RFQ |
| Contact: | Tim Frankenberg 200 E. 14th Street Washington, MO 63090 636-390-1020 tpfrankenberg@washmo.gov |
| Deadline: | 12:00 p.m., CDT on Friday, December 8, 2023 |

Pursuant to the Brooks Act for Consultant Selection-the following criteria will be the basis for selection.

- Experience and Technical Competence..... Max Points 30
- Capacity and Capability..... Max Points 25
- Availability of staff assigned to project to attend project meeting and meet for on-site consultation..... Max Points 10
- Past Record of Performance..... Max Points 25
- Outline consultants QA/QC plan..... Max Points 10

Fire Station Construction Schedule:

1. RFQ out..... 11/17/23
2. RFQ received 12/18/23
3. Consultant chosen 12/21/23
4. CC approves contract..... 1/2/24
5. OTB.....4/1/24
6. Bids received.....5/1/24
7. CC approves contract.....6/3/24
8. Construction start..... 7/15/24
9. Material lead time..... 8/15/24
10. Completion.....2/1/25



Washington FD
Training Center

Washington
Downtown

Missouri River

MO-100

Phoenix Center Park

Washington FD
Proposed New
Fire Station
(TBV)



INVESTING IN THE FUTURE OF YOUR AGENCY AND STAFF BY
BUILDING THE RIGHT FACILITY TODAY

FGMARCHITECTS



Phoenix
Center Park

Washington FD
Proposed New
Fire Station
(TBV)

Stone Crest Subdivision

MO-100



INVESTING IN THE FUTURE OF YOUR AGENCY AND STAFF BY
BUILDING THE RIGHT FACILITY TODAY

FGMARCHITECTS



Phoenix Center Park

Phoenix Center Drive

MO-100

S. Point Road

Vernaci Drive

Washington FD Proposed New Fire Station (TBV)

Earth Crest Drive

Stone Crest Subdivision



INVESTING IN THE FUTURE OF YOUR AGENCY AND STAFF BY BUILDING THE RIGHT FACILITY TODAY

FGMARCHITECTS

Washington Fire Department / City of Washington, Missouri

New Fire Station at MO-100 and Phoenix Center Drive

FGMAARCHITECTS

January 26, 2024

FGM Project No. 24-XXXX.01

Phase by Phase - FEE MATRIX

| Consultant / Firm | | Discipline of Service | | | | | sub-Total | Remarks |
|--|--|-----------------------|---------------|--------------|------------|-------------|------------|--|
| A. Ph I (Conceptualization: Program Verification, Scope-Cost-Schedule Document) | | | | | | | | |
| 1.0 | Site (Concept, Due Diligence) | Civil | Land Survey | Title Search | Enviro. | Geotech. | | |
| .1 | Bacon Farmer Workman (BFW) | \$ 4,000 | | | \$ 8,500 | \$ 7,500 | \$ 20,000 | Verify enviro required - cost is a maximum based on parcel count |
| .2 | Thouvenot, Wade and Moerchen (TWM) | | \$ 12,100 | with survey | | | \$ 12,100 | Verify survey and title required (not ALTA); includes reimb. |
| .3 | Intertek PSI (PSI) | | | | | \$ 6,980 | \$ 6,980 | |
| .4 | Reserved | | | | | | \$ - | |
| .5 | Category 1.0 sub-Total | | | | | | \$ 32,100 | Includes Geotech by BFW only; includes Direct to Owner value(s) |
| 2.0 | Building (Concept) | Structural | Mechanical | Plumbing | Electric | Low-Voltage | | |
| .1 | Bacon Farmer Workman (BFW) | \$ - | | | | | \$ - | |
| .2 | Marcum Engineering (Marcum) | | \$ 7,000 | with Mech. | with Mech. | with Mech. | \$ 7,000 | |
| .3 | Reserved | | | | | | \$ - | |
| .4 | Category 2.0 sub-Total | | | | | | \$ 7,000 | |
| 3.0 | Building (Program, Concept, Estimate) | Architecture | Interior Des. | Landscape | Furniture | Low-Voltage | Estimate | |
| .1 | FGM Architects Inc. (FGMA) | \$ 12,500 | with Arch. | with Arch. | with Arch. | with Arch. | with Arch. | \$ 12,500 |
| .2 | Middleton Consulting & Contracting (MCC) | | | | | | \$ 3,500 | \$ 3,500 |
| .3 | Reserved | | | | | | \$ - | |
| .4 | Category 3.0 sub-Total | | | | | | \$ 16,000 | |
| 4.0 | TOTAL - Phase I Consulting Costs | | | | | | \$ 55,100 | Includes Direct to Owner value(s) |

Washington Fire Department / City of Washington, Missouri

New Fire Station at MO-100 and Phoenix Center Drive

FGMARCHITECTS

January 26, 2024

FGM Project No. 24-XXXX.01

Phase by Phase - FEE MATRIX

| Consultant / Firm | Discipline of Service | | | | | | sub-Total | Remarks |
|--|-----------------------|---------------|------------|------------|-------------|------------|------------|--|
| B. Ph II (Implementation: Design, Documentation, Bidding and Contract Administration) | | | | | | | | |
| 5.0 Site (Engineering) | Civil | Land Survey | Landscape | | Geotech. | Testing | | |
| .1 Bacon Farmer Workman (BFW) | \$ 25,000 | | | | \$ 7,500 | | \$ 32,500 | Geotech service is Site-Specific Seismic Hazard Analysis (SSSHA) |
| .2 Thouvenot, Wade and Moerchen (TWM) | | \$ 2,200 | | | | | \$ 2,200 | Allowance for private utility locate |
| .3 Dermody & Associates (Dermody) | | | \$ 7,000 | | | | \$ 7,000 | |
| .4 Intertek PSI (PSI) | | | | | \$ 8,900 | \$ 10,000 | \$ 10,000 | Geotech service is (SSSHA); Testing and Inspections is Estimate Only |
| .4 Reserved | | | | | | | \$ - | |
| .5 Category 5.0 sub-Total | | | | | | | \$ 51,700 | Includes Geotech by BFW only; includes Direct to Owner value(s) |
| 6.0 Building (Engineering) | Structural | Mechanical | Plumbing | Electric | Low-Voltage | Testing | | |
| .1 Bacon Farmer Workman (BFW) | \$ 36,500 | | | | | | \$ 36,500 | Includes ICC-500 Peer Review |
| .2 Marcum Engineering (Marcum) | | \$ 117,640 | with Mech. | X | X | | \$ 117,640 | |
| .3 Intertek PSI (PSI) | | | | | | \$ 30,000 | \$ 30,000 | Testing and Inspections is Estimate Only |
| .4 Reserved | | | | | | | \$ - | |
| .5 Category 6.0 sub-Total | | | | | | | \$ 184,140 | Includes Direct to Owner value(s) |
| 7.0 Building (Architecture and Interiors) | Architecture | Interior Des. | | Furniture | Low-Voltage | Estimate | | |
| .1 FGM Architects Inc. (FGMA) | \$ 287,750 | with Arch. | | with Arch. | with Arch. | with Arch. | \$ 287,750 | Verify furniture and equipment required |
| .2 Middleton Consulting & Contracting (MCC) | | | | | | \$ 5,000 | \$ 5,000 | |
| .3 Reserved | | | | | | | \$ - | |
| .4 Category 7.0 sub-Total | | | | | | | \$ 292,750 | |
| 8.0 TOTAL - Phase II Consulting Costs | | | | | | | \$ 528,590 | Includes Direct to Owner value(s) |

Washington Fire Department / City of Washington, Missouri

FGMARCHITECTS

New Fire Station at MO-100 and Phoenix Center Drive

January 26, 2024

Phase by Phase - FEE MATRIX

FGM Project No. 24-XXXX.01

| Consultant / Firm | Discipline of Service | sub-Total | Remarks |
|--|---|-------------------------|---|
| C. Analysis | | | |
| 9.0 | PROJECT PHASES AND FEES | | |
| .1 | Ph I - Conceptualization Total | \$ 55,100 1.17% | |
| .2 | Ph II - Implementation Total | \$ 528,590 11.25% | |
| .3 | Gross (Ph I + Ph II) Consulting, Services | \$ 583,690 | Includes Direct to Owner value(s), all Supplemental Services |
| .4 | Less Enviro., Geotech, and Testing / Inspections | \$ 56,000 | To be contracted Direct to Owner |
| .5 | Less Conceptualization Phase, Survey, Title, SSSHA, ICC-500 Peer Review and Third-Party Cost Estimating | \$ 44,200 | Certain Supplemental Service(s) typically not in Fee % |
| .6 | Less Contract Administration | \$ 94,000 | Can be performed on an Hourly Not To Exceed Basis if preferred |
| .7 | Net (Ph I + Ph II) Consulting | \$ 389,490 8.29% | |
| .8 | Estimated Hard-Cost + FFE Value Range 9,000-12,000 SF SQ: 10,000 \$ 470.00 SF | \$ 4,700,000 | Excludes Land Acquisition and Financing Costs, if any |
| .9 | Net (Ph I + Ph II) Consulting Fee as a Percentage of Estimated Hard-Cost + FFE Value | 8.29% | |
| .10 | Reimbursable Costs | \$ 8,200 | Estimated |
| .11 | Grand Total Project Cost | \$ 5,291,890 | Includes Direct to Owner value(s), all Supplemental Services, Reimb. |
| D. Legend and Notes | | | |
| 1.0 | Fees would be for scope per B101-2017 Master Agreement. | | |
| 2.0 | Terms for invoicing would be per B101-2017 Master Agreement. | | |
| 3.0 | Direct to the Owner Services indicated as shaded. Costs have still been included herewith to show Project all-in cost. | | |
| 4.0 | Basic Services indicated as shaded. | | |
| 5.0 | Supplemental Services indicated as shaded. | | |
| 6.0 | Additional Services note indicated herewith; refer to B101-2017 Master Agreement. | | |
| 7.0 | Services excluded / recommended to be performed by other. | | |
| 8.0 | The project will not seek to achieve USGBC Green Building certification or similar sustainable initiatives. | | |
| 9.0 | Project construction would be procured through competitive bid, single bid event - assuming General Contractor. | | |
| S:\jobs\mk_oh\M4-0633.00_Washington_MO_Fire_Station\Fee Development\m4-0633_washington FD fee matrix - 2024.01.19.xlsx | | | |



City of Washington Fire Department
200 E. Fourteenth Street, Washington, MO 63090

Phone 636-390-1020 www.washmo.gov

www.washmofire.org

Professional Volunteer Service Since 1852



January 31, 2024

Darren Lamb, City Administrator
405 Jefferson Street
Washington, MO 63090

RE: Fire Station Design & Budget Amendment

Dear Darren:

Attached you will find an ordinance to approve the design of the Fire Station at Phoenix Park and a budget amendment.

This City issued Request for Qualifications for the design and construction management for a new fire station. Nine companies submitted packets and a committee including Mayor Hagedorn, yourself, Councilman Patke, Councilman Coulter, Assistant Fire Chief Mark Skornia any myself reviewed these packets. The submissions were scored and there were four viable candidates identified.

The fire department reached out and spoke to a number of other fire departments and fire districts about their experiences with the various design companies. The committee identified four of the firms to be candidates and opted to interview the top two. The top two were local to the St. Louis market whereas, the others were located in other states. The top two were interviewed and provided a 60 minute presentation. Both did an exceptional job showcasing what they had to offer and address specific questions about the project.

FGM Architects was the top candidate and called to move forward with a proposal and contract. Their fees are broken down in the spreadsheet that is included as part of the submission titled FGM Project No.24-0000.01. They are proposing a two phase design process and additional consulting services. There services for design is estimated to be at 8.29% of the cost of the project. The work will be broken down into a number of phases.

Phase 1 is the conceptual process for the design. This includes visiting existing City of Washington Fire Stations, surveying personnel for needs and wants and blending this with code requirement and best practices. This would develop the baseline of the design balancing the wants and needs to the budget. This phase is estimated at \$55,100.

The second phase include the design utilizing two primary engineering firms that are sister companies for the complete set of construction documents for bidding. In addition, we asked FGM to provide complete cost for all aspects including geotechnical report, surveying, testing, third party cost estimating and peer reviewing of the design. The total for the design services is \$389,490.

Also, requested of FGM was to provide the quality assurance for the construction materials and site testing. This includes concrete and wall sample testing, weld testing services, etc. There is an option

for the City to bid this separately, however, it is recommended the entire project is managed by FGM rather than split contracts. If the testing was managed by the City separately, there would need to be a significant amount of coordination between the general contractor, sub-contractors and the testing companies.

Finally, FGM was requested to submit a quotation for project management. This includes tracking all labor and certifying the submissions from the contractor and subcontractors, overall site oversight and coordination with the contractor. FGM submitted a quotation of \$94,000 for these services.

The total package from FGM Architects is quoted at \$583,690 for all services including the survey, geotechnical, architecture, engineering, bid solicitation, assistance in contractor selection, construction management, quality management, interior design, furniture selection assistance, closeout and one year post construction inspection.

The cost of construction have escalated significantly in the past three to four years. The estimated cost of construction is \$470 per square foot of a building between 9,000 and 12,000 square feet. The budget for the fire station is \$4M from the Capital Improvement Sales Tax, \$500,000 from the Washington Community Fire Protection District based on contract and balance from the fire department reserve fund. The total estimated cost is \$5,291,890. We are expecting to trim that number some as we have found some savings and intend to work as diligently as possible to provide the maximum return for this investment. We are designing this building for a 50 year life.

In closing, the monies for the design need to be moved from the fire department reserve fund to cover these services. The estimated services in the 2024 budget should not exceed \$500,000. This includes the design, contractor selection, site testing and surveying. It is estimated that the total reserve spend will be approximately \$800,000.

If you have any questions, please let me know.

Respectfully,



Tim Frankenberg, CFPS, CSP
Fire Chief

BILL NO. _____ INTRODUCED BY _____

ORDINANCE NO. _____

AN ORDINANCE AUTHORIZING AND DIRECTING THE EXECUTION OF A CITY-CONTRACTOR AGREEMENT BY AND BETWEEN THE CITY OF WASHINGTON, MISSOURI AND SIEVE CONTRACTORS, INC & AMEND THE 2023/2024 BUDGET

BE IT ORDAINED by the Council of the City of Washington, Missouri, as follows:

SECTION 1: The Mayor is hereby authorized and directed to execute an Agreement by and between the City of Washington, Missouri and Sieve Contractors, Inc., a copy of which is marked Exhibit A and is attached hereto and incorporated herein by reference, and such other documents, certificates and instruments as may be necessary or desirable to carry out and comply with the intent of this Ordinance, for and on behalf of and as the act and deed of the City. The City Clerk is hereby authorized and directed to attest to and affix the seal of the City to the said Agreement and such other documents, certificates and instruments as may be necessary or desirable to carry out and comply with the intent of this Ordinance.

SECTION 2: The City shall, and the officials, agents and employees of the City are hereby authorized and directed to, take such further action, and execute and deliver such other documents, certificates and instruments as may be necessary or desirable to carry out and comply with the intent of this Ordinance.

SECTION 3: The 2023/2024 Budget is hereby amended Capital Improvement Sales Tax -Increase \$61,000 for Public Works Front Office Renovations (260-18-000-540200).

SECTION 4: All ordinances or parts of ordinances in conflict herewith are hereby repealed.

SECTION 5: This ordinance shall be in full force and effect from and after its passage and approval.

Passed: _____

ATTEST: _____

President of City Council

Approved: _____

ATTEST: _____

Mayor of Washington, Missouri

EXHIBIT A
CITY-CONTRACTOR AGREEMENT

This Construction Agreement ("Agreement") is entered into effective as of the **5th day of February, 2024** ("Effective Date") by and between "**Sieve Contractors, Inc.**", a Missouri for-profit corporation with offices located at "**6 Chamber Drive, Washington, MO**", ("Contractor"), and the City of Washington, Missouri (hereinafter called the "City") (Contractor and the City may hereafter individually be referred to as a "Party" or collectively referred to as the "Parties").

WHEREAS, the Parties desire to enter into an Agreement under which the Contractor is to provide Work as described in this Agreement, currently owned, managed, or otherwise under the stewardship of the City;

WHEREAS, the Contractor has submitted documentation to the City, in the manner and time specified, a proposal in accordance with the terms of the Agreement and;

WHEREAS, the City has examined and canvassed the proposal submitted, and as a result, has determined and declared the Contractor to be the best bidder for constructing said Work, and has duly awarded to the said Contractor contract therefor, for the sums named in the proposal attached to and made a part of this contract:

NOW THEREFORE, THIS AGREEMENT WITNESSETH, in consideration of the recitals stated above, which all Parties agree are accurate and complete, the agreements, promises, and warranties set forth below, and other good and valuable consideration, the receipt and sufficiency of which is hereby acknowledged, the Parties agree as follows:

ARTICLE I.
SCOPE AND DEFINITIONS

SECTION A. SCOPE OF THE AGREEMENT

Implementation of the Agreement

Paragraph 1.1. This Agreement, and its related Exhibits and Attachments, attached hereto and incorporated herein for all purposes, comprise the entire contract between the City and Contractor concerning the Work. It may be altered only by a written Modification or Change Order.

Paragraph 1.2. It is the intent of the Agreement to describe a complete Project. Any Work that may reasonably be inferred from the Agreement as being required to produce the intended result shall be supplied by the Contractor at no additional cost to the City, whether or not it is specifically called for.

SECTION B. DEFINITIONS

Wherever used in the Agreement the following terms have the meanings indicated which are applicable to both the singular and plural thereof:

Paragraph 1.3. "Additional Work" or "Additional Services" means Work beyond the scope of services identified in the specifications described in the Bid Document.

Paragraph 1.4. "Agreement" or "Contract" means this signed written agreement between the City and Contractor covering the Work to be performed by Contractor, and other Addenda, attachments and Exhibits to this Agreement and made a part thereof as provided herein.

Paragraph 1.5. "Application for Payment" means the form approved by the City which is to be used by Contractor in requesting progress or final payment and which is to include such supporting documentations as is required by the Agreement.

Paragraph 1.6. "Bonds" means bid and/or performance bond or other instruments of security.

Paragraph 1.7. "Change Order" means a written order to Contractor signed by the City authorizing an addition, deletion, or revision in the Work, or an adjustment in the Contract Price issued after the Effective Date of the Agreement.

Paragraph 1.8. "Commencement Date" means the date upon which the Work shall begin.

Paragraph 1.9. "Contract Price" means the monies jointly and separately due and payable by the City to Contractor under this Agreement.

Paragraph 1.10. "Day" means a calendar day of twenty-four hours measured from midnight to the next midnight.

Paragraph 1.11. "Modifications" means (a) a written amendment of the Agreement signed by both Parties, or (b) a Change Order.

Paragraph 1.12. "Owner" means the City. "Owner's Representative" means Eagan Building Group.

Paragraph 1.13. "Permit" means a written permit issued by any local, State, or Federal agency, or other legal authority, as required to conduct the Work.

Paragraph 1.1.4. "Person" means an individual, partnership, joint venture, corporation, limited liability company, or unincorporated organization.

Paragraph 1.15. "Project" means the total scope of Work specified in the Agreement.

Paragraph 1.16. "Report" means weekly, monthly, quarterly, or yearly report that demonstrates the tasks completed over that period of time.

Paragraph 1.17. "Subcontractor" means a Person having a direct contract with Contractor or with any other subcontractor for the performance of part of the Work.

Paragraph 1.18. "Third Party" or "Third Parties" means any Person other than a member of Contractor or the City.

Paragraph 1.19. "Unit" means a specific quantity of material or service (per park, per gallon, per tree, per mile, per track, per, acre, per sculpture, linear feet, square feet, etc.).

Paragraph 1.20. "Unit Price" means the dollar amount per Unit as quoted/bid in Exhibit "A".

Paragraph 1.21. "Work" means all of the services, labor, equipment and materials to be performed, provided, or furnished by Contractor as required by the Agreement.

ARTICLE II. CONTRACT ADMINISTRATION

SECTION A. CONTRACT FORMATION, INTERPRETATION, ASSIGNMENT, AND SUBCONTRACTS

Subcontracting and Assignments

Paragraph 2.1. Contractor shall supply a complete list of any and all subcontractor(s) proposed to be used under the Agreement and shall not use any Subcontractor or other Person (including those who are to furnish the principal items of material or equipment), whether initially or as a substitute, without the prior written consent of the City.

Once a subcontractor(s) has been approved by the City, the Contractor shall submit a signed and dated Contract between the Contractor and the subcontractor indicating the total dollar amount of the subcontractor's Contract. Before any subcontractor can begin work on the project, whether originally subcontracted prior to the start of the project or subcontracted after the project has begun all provisions of this article must be complied with.

Paragraph 2.2. The City may assign this Agreement in part or in whole including all rights and obligations to any assignee at its sole discretion and without any prior notice or consent from Contractor including but not limited to any entity that succeeds to any of the rights and obligations to provide governmental type services to the local community, including any city, county or state agency, and/or a newly formed municipality. Upon any such assignment by the City, this Agreement shall remain a valid and enforceable agreement and the original terms and conditions contained herein, or

any properly amended terms and conditions shall remain valid and enforceable. Contractor shall not assign this Agreement, including to any Affiliates, without the City's prior written consent. Any purported assignment without such consent shall be void.

Paragraph 2.3. Contractor shall be fully responsible for all acts and omissions of its Subcontractors, of all Persons directly or indirectly employed by them and Persons for whose acts any of them may be liable to the same extent that Contractor is responsible for the acts and omissions of Persons directly employed by Contractor. Nothing in the Agreement shall create any contractual relationship between the City and any Subcontractor, except as may otherwise be required by law.

SECTION B. TERM

Paragraph 2.4. This Agreement shall be effective within ten (10) consecutive calendar days of the date of the Notice to Proceed, and shall be completed by 60 Days after execution of contract.

Paragraph 2.5. This Agreement shall continue from the Effective Date until terminated by the expiration of the Term as indicated in the Bid Documents or by termination procedures as described in this Agreement.

Paragraph 2.6. If Contractor is delayed at any time in the commencement or progress of the Work by an act or neglect of the City, or of an employee, or of a separate contractor employed by the City; or by a Change Order in the Work; or by labor disputes, fire, unusual delay in deliveries, unavoidable casualties or other caused beyond the Contractor's control; or by delay authorized by the City pending mediation and arbitration; or by other causes that the City determines may justify delay, then the Contract Time shall be extended by Change Order for such reasonable time as the City may determine.

SECTION C. CONTRACT COMMUNICATION

Notices

Paragraph 2.6. All notices, requests, demands, and other communications specifically required or authorized by this Agreement shall be written and shall be (a) delivered personally, (b) mailed by registered mail or certified mail, return receipt requested, postage prepaid, (c) sent by facsimile transmission, or (d) sent by e-mail. All such communications shall use the receiving Party's contact information as contained in this Article II Section C. A Party may change its contact information by sending a notice to the other Party complying with these notice requirements.

Paragraph 2.7. All other communications, including telephone, regular mail, e-mail, and other informal communication methods, shall be effective only when the responsible officer, director, manager, or supervisor of the receiving Party has actual knowledge of the communication.

Paragraph 2.8. Contractor's contact information is as follows:

Sieve Contractors, Inc.
Attn: Dan Forget
6 Chamber Drive
Washington, MO 63090
Telephone: (636) 239-5685
E-mail: dforget@sievecontractors.com

Paragraph 2.9. City of Washington contact information is as follows:

CITY OF WASHINGTON
Attn: Wayne Dunker
Parks & Recreation Director
405 Jefferson Street
Washington, Missouri 63090
Telephone: 636-390-1080
E-mail: wdunker@washmo.gov

SECTION D. CONTRACT PERFORMANCE

Work

Paragraph 2.10. Contractor, acting as an independent contractor, agrees to furnish at his/her own expense all supervision, labor, expertise, equipment, supplies, and other requirements as set forth herein and as more specifically described in the Bid Documents and will provide such in a good and "Workmanlike Manner", the term Workmanlike Manner being defined as the rendition of services in a manner deemed proficient by those with the special knowledge, training, and experience to judge such services and in accordance with highest generally accepted standard of care in the industry.

The Work approved for the Public Works Office Renovation – includes the following:

- Base Bid (General Construction) \$72,000
- Alternate #1 (Replacement of ceiling tiles) \$6,000
- Alternate #2 (Replacement of casework) \$2,500
- Number of days until Completion 60 consecutive calendar days

Contractor as an Independent Contractor

Paragraph 2.11. At all relevant times to this Agreement, Contractor shall act as an independent contractor to the City in providing Work to the City. Nothing in this Agreement shall be interpreted to create any employment, partnership, or joint ventures. Except to the extent required to enable Contractor to perform his/her specific duties under this Agreement, Contractor shall not act as an agent of the City, by entering into this Agreement, the City in no way, assumes any liabilities, debts or obligations of the Contractor whether now existing or hereafter created.

Paragraph 2.12. Contractor shall not have the authority to incur or assume any debt, obligation, expense, or liability against the City, and shall not have the authority to bind or otherwise obligate the City to any contracts, agreements, warranties, or understandings.

Change Orders

Paragraph 2.13. Any Change Orders or Modifications to the Agreement must be approved by the City and be incorporated by written amendment to the Agreement. Contractor shall not have the authority to make, revise, alter, depart, or otherwise diverge from any of the terms, conditions, or places furnished to Contractor by the City and/or this Agreement absent consent of the City and written amendment to the Agreement.

Continuing the Work

Paragraph 2.14. Contractor shall carry on the Work and maintain the performance of the Work during all disputes or disagreements with the City, except upon the City's default hereunder. No Work shall be delayed or postponed pending resolution of any disputes or disagreements, except as the Parties may otherwise agree in writing.

Equipment Storage

Paragraph 2.15. Contractor shall be responsible for locating and providing storage for all equipment.

Permits

Paragraph 2.16. Contractor shall be solely responsible for obtaining and paying for all permits and licenses related to their performance of the Work.

Taxes and Fees

Paragraph 2.17. Contractor shall pay all taxes and fees which may be chargeable against the performance of the Work, or incident to the Agreement by a government agency, including but not limited to any employment related taxes, F.I.C.A. taxes, social security taxes, and other taxes and fees, directly to the appropriate governmental

bodies. The City is a political subdivision of the State of Missouri and exempt from tax; The City agrees to make their tax-exempt certification available to the Contractor to the extent required to assure the City is not charged taxes which they are not responsible to pay. The City shall not be liable in any way for such fees or taxes and the Contractor shall indemnify and hold the City, their Affiliates officers, directors, members, and employees and assigns harmless from and against all claims, demands, causes of action, suits or other litigation in connection with Contractor's failure to report such taxes and fees. No additional compensation will be paid to Contractor for taxes or fees.

Contract Price and Payment Procedures

Paragraph 2.18. Contract Price constitutes the total compensation (subject to authorized adjustments made by a Change Order) payable to Contractor for performing the Work. All duties, responsibilities and obligations assigned to or undertaken by Contractor shall be at its expense without change in the Contract Price. The City agrees to pay, and the Contractor agrees to accept, for the performance of the Contract, the sum of **Eighty Thousand Five Hundred Dollars and zero Cents (\$80,500.00)**, subject to additions and deductions as provided in the Contract Documents.

Paragraph 2.19. Contractor shall submit to the Owner's Representative monthly Applications for Payment that shows all applicable areas where the Work was performed. Failure to fully comply with the Application for Payment procedure will cause daily in processing payments.

Paragraph 2.20. On the twenty-fifth (25th) day of each month and no later than the thirtieth (30th) of the month during the Term of the Agreement, beginning with the first (1st) month after the Commencement Date, Contractor shall submit to the Owner's Representative the Application for Payment, accompanied by (a) the monthly Report, (b) a sworn statement by Contractor certifying (i) the Application for Payment is correct, (ii) all insurance required by this Agreement is in full force and effect, (iii) all Subcontractors and suppliers have been paid from previous Applications for Payment, (iv) Certified payroll, and (v) the Contractor is not in default under any provisions of the Agreement and that no event has occurred which with the passing of time or the giving of notice could be a default under the Agreement, and (c) any other documents, information or data which the City request be provided.

Paragraph 2.21. If the City or Owner's Representative disputes any portion of an Application for Payment, they shall, within thirty (30) Days of receipt of the Application for Payment, furnish the Contractor a reasonably detailed explanation of the objection, and may withhold payment on the portion in dispute. If Contractor objects to the withholding, it shall provide the City with written notice of its objection within ten (10) Days of receipt of the written explanation from the City. The Parties may then proceed to Dispute Resolution as described in this Agreement as to any disputed amount. All undisputed amounts shall be paid within forty-five (45) Days of the receipt of the Application for Payment by the City.

Paragraph 2.22. Contractor shall notify the City in writing within ten (10) Days of their receipt of payment from the City, if there is any discrepancy based on a Contractor audit of the number of Units. This notice shall include the nature of the disagreement, the address of the location of the Unit in question, the type of service being provided, and the date such service began or ended. If the Contractor does not notify the City of a discrepancy within the ten (10) Day period, the discrepancy is waived, and the Contractor is afforded no further recourse, right or remedy as to the discrepancy.

Paragraph 2.23. At any time during the Term of the Agreement, the City may alter the number of Units applicable to the Work. If the number of Units is increased, the Work on any additional Units will be paid to Contractor in an amount equal to the number of additional Units multiplied by the Unit Price herein. If the number of Units are decreased, the Contract Price will be reduced in an amount equal to the number of Units decreased multiplied by the Unit Price. Unit Price and Units are described in the specifications in Exhibit "A".

Paragraph 2.24. Final Payment, constituting the entire unpaid balance of the Contract Sum, shall be made by the City to the Contractor when: the Contractor has fully performed the Contract except for the Contractor's responsibility to correct Work, and to satisfy other requirements, if any, which extend beyond final payment; and a final Certificate for Payment has been issued.

Liquidated Damages

Paragraph 2.25. Contractor and City recognize that time is of the essence and that City may suffer financial loss if the Work is not completed within the times specified in the Bid Document, plus any extensions thereof allowed. The Parties also recognize the delays, expense, and difficulties involved in proving in a legal or arbitration proceeding the actual loss suffered by City if the Work is not completed on time. Accordingly, instead of requiring any such proof, City and Contractor agree that as liquidated damages for delay (but not as a penalty), Contractor shall pay City \$100.00 for each day that expires after the time specified in the Bid Document above until the Work is complete.

Character and Conduct of Contractor's Employees and Subcontractors

Paragraph 2.26. The Contractor's employees and Subcontractors who normally and regularly come into direct contact with the public shall bear some means of company identification such as a company uniform with name badges, name tags or identification marks. Vehicles and equipment shall also bear some means of company identification (as identified in the Bid Document).

Paragraph 2.27. The Contractor shall perform the Work with as little noise and as little disturbance to Third Parties and surrounding property owners as possible.

Paragraph 2.28. Care shall be taken by Contractor to prevent damage to property, including buildings, sidewalks, parking lots, trails, roads, pavilions, playgrounds, lawns, shrubs, flowers, trees, plants, etc. on City-Owned Property, Rights-of-Ways or of Third Parties.

Safety and Protection

Paragraph 2.29. Contractor shall be responsible for initiating, maintaining and supervising all safety precautions and programs in connection with the Work. The Contractor shall appoint a qualified, experienced safety representative, whose duties shall be the prevention of accidents and the maintaining and supervision of the safety precautions and programs.

Injury or Damage

Paragraph 2.30. Contractor shall promptly notify the City of all damage to property belonging to the City or Third Parties, or injuries incurred by persons other than employees of Contractor in no case later than one (1) hour after the injury or damage occurred.

Paragraph 2.31. Contractor shall be responsible for any damage to the property, real or personal, of any Third Party or of the City that is caused by any act or omission of the Contractor in the performance under the Agreement. If the City finds that the Contractor has failed to completely reimburse the Third Party any amount and the City, and the City deems it necessary to compensate the Third Party for its damaged property, the City may pay the Third Party and deduct this amount from the amount due to Contractor under this Agreement. The City reserves the right to pay all fines, penalties, costs and assessments levied by any governmental authority against the Contractor and to withhold said amount from any payments due to Contractor under this Agreement. The terms and conditions of this paragraph shall survive the termination of this Agreement.

SECTION E. PERFORMANCE AND TERMINATION

Force Majeure

Paragraph 2.32. Contractor and the City shall be excused from complying with the terms and conditions of this Agreement if, to the extent, and for as long as, such Party's compliance is delayed or prevented by a Force Majeure event. A Force Majeure event will not excuse either Party from making payments, performing indemnity obligations (as applicable), or other duties not directly limited by the Force Majeure event, except as otherwise provided within this paragraph entitled "Force Majeure". "Force Majeure" includes acts of God, floods, blizzards, ice storms, and hurricanes; insurrection, revolution, piracy, and war. Strikes, slowdowns, walkouts, lockouts, industrial disturbances and labor disputes are not excused under this provision.

Provisions Surviving Termination

Paragraph 2.33. In the event of termination of this Agreement, the terms and conditions which expressly survive termination of this Agreement and those dealing with warranty, indemnities, audit, confidentiality, insurance, arbitration, disclaimer of consequential damages and any limitation of liability, shall survive termination and remain in full force and effect.

Termination by the City

Paragraph 2.34. The City may terminate the Agreement upon 1) thirty (30) Days written notice for any reason, or 2) upon any of the following events of default ("Events of Default") if after giving the Termination Notice described in Paragraph 2.36, the Contractor has not cured the Event of Default within the applicable cure period:

- A. If Contractor fails to fulfill or maintain in a timely and proper manner any obligations, duties or provision of the Agreement, and Contractor fails to cure such default to the satisfaction of the City within ten (10) Days of the Contractor's receipt of written notice from the City specifying the how the Contractor failed to perform in reasonable detail.
- B. If Contractor is adjudicated voluntarily bankrupt, or if Contractor is subject to the appointment of receiver or trustee and fails to have the receiver or trustee removed within sixty (60) Days, or if any assignment or Contractor's property shall be made for the benefit of creditors, or if Contractor becomes insolvent, or unable to pay its debts as they become due.
- C. If there is a change of Control of the Contractor, whether voluntarily or by operation of law, or substantially all the assets of the Contractor are sold or transferred voluntarily or otherwise, the Agreement shall terminate unless the City agrees by Change Order to continue the Agreement with the Contractor after the change of Control or disposition of assets. The Contractor shall promptly notify the City of any actual or proposed change in, transfer of or acquisition by another party of Control of the Contractor. "Control" as used herein means the power, whether direct or indirect, to direct the affairs of the Contractor by whatever manner exercised. Any agreement by the City to continue this Agreement after the change in Control or disposition of assets shall be contingent upon the new controlling party or owner of the assets becoming a signatory to the Agreement and otherwise complying with all the terms and conditions herein, including but not limited to the submission of Bonds, if required by this Agreement, and certificates of insurance acceptable to the City.

Administrative Fee

Paragraph 2.35. If there is an Event of Default which the Contractor does not cure within the applicable cure period, the City may charge and the Contractor shall pay to the City an administrative fee to compensate the City for its costs associated with the Contractor's failure to perform the Work as required in this Agreement. The City may levy this administrative fee without terminating this Agreement. The fee shall be equal to

1.5 times the Unit Cost multiplied by the number of Days the Event of Default continues uncured after the expiration of the applicable cure period and shall be payable to the City by the Contractor upon written demand. The Parties stipulate that the fee is a reasonable estimate and is not to be construed as a fine or penalty, and shall be in addition to any other remedy the City may have at law, in equity or under the Agreement.

Termination Notice: Cancellation of Orders and Subcontracts

Paragraph 2.36. Upon the occurrence of an Event of Default subject to any applicable notice and cure period, the City should they elect to terminate the Agreement, will issue a written notice of termination (the "Termination Notice") to the Contractor. In addition, the City may issue a Termination Notice for any reason as so long as the Contractor is given thirty (30) Days' notice in the Termination Notice. Termination shall be effective upon the date specified in the Termination Notice, and upon said date this Agreement shall be deemed immediately terminated and thereafter neither Party shall have any rights or obligations under this Agreement except as expressly provided herein. Any termination of the Agreement shall not relieve the Contractor (a) from the obligation to pay any fees, taxes or other charges then due to the City or any other Third Party incident to the Agreement, (b) from the obligation to file any monthly, quarterly or annual Reports through termination, (c) from any claim from damages previously accrued or then accruing against the Contractor nor (d) from any provisions of this Agreement that expressly survive termination. Upon the effective date of termination as contained in the Termination Notice, Contractor shall, unless the notice directs otherwise, immediately discontinue all Work and shall proceed to promptly cancel all existing orders and subcontracts for the Work. Contractor shall immediately submit an Application for Payment showing in detail the Work performed through the date of termination. The City agrees to compensate the Contractor for that portion of Work actually performed prior to the effective date of termination and not disputed under this Agreement and not previously paid, less any charges, deductions, or administrative fees. Termination of this Agreement shall not affect any rights or remedies of the City against Contractor then existing or which may thereafter accrue. Any retention or payment of monies due Contractor by the City shall not release Contractor from liability.

Termination or Stop Work by Contractor and Remedies for Default by the City

Paragraph 2.37. If through no act or fault of Contractor, the Work is suspended for a period of more than ninety (90) Days by the City or under an order of court or other public authority, or the City fails for sixty (60) Days to pay Contractor any sum not in dispute, or if the City otherwise default hereunder, then Contractor may, (i) upon fifteen (15) Days written notice to the City, and provided the City does not remedy such suspension or failure to pay within that time, terminate this Agreement and recover payment from the City for the undisputed Work which Contractor completed prior to the effective date of termination, or (ii) upon seven (7) Days written notice to the City stop the Work until payment of all such amounts due Contractor are received, without termination of this Agreement as the Contractor's sole and exclusive remedies.

**ARTICLE III.
CONTRACTOR'S REPRESENTATIONS AND WARRANTIES**

General Service Warranty

Paragraph 3.1. The general service warranty applies to all services performed by Contractor or its subcontractors. Contractor warrants it will perform all services in a good and Workmanlike Manner.

Contractor's Representations and Warranties

Paragraph 3.2. Contractor is familiar with the nature and extent of the Agreement, the Work, the locality, with all local conditions and federal, state, and local laws, ordinances, rules, and regulations including but not limited to all rules, regulations, and the restrictive covenants governing the land within the jurisdiction of the City, that in any manner may affect cost, progress or performance of the Work.

Paragraph 3.3. The person signing this Contract on behalf of the Contractor is authorized by Contractor to do so.

Paragraph 3.4. Contractor's representations and warranties under this Article III of the Agreement entitled Contractor's Representations and Warranties will survive the termination of this Agreement.

**ARTICLE IV.
FINANCIAL ADMINISTRATION**

SECTION A. APPLICATIONS FOR PAYMENT AND PROCEDURES

Contractor's Invoices

Paragraph 4.2. Applications for Payment shall be submitted in such form and accompanied by such certification and documentation as the City may reasonably request, including the following as applicable: (a) Daily rate and the number of days worked in performing the Work, (b) the type and quantities of materials or supplies furnished by Contractor and utilized in performing the Work (e.g. chemicals), (c) the dates and hours equipment or machinery was employed in performing the Work, (d) Report on number of acres cleared, and (e) any charges for extra services authorized by the City (Each service must be individually listed next to its charge and approved proposals or Change Orders must be included).

Payment of Application for Payment

Paragraph 4.3. Except as provided in the paragraph entitled "Disputed Invoices," the City agrees to pay Contractor's Application for Payment within thirty (30) Days after the City's receipt of the Application for Payment.

Remedies for Unpaid Invoices

Paragraph 4.4. Undisputed Applications for Payment or the undisputed part of an Application for Payment remaining unpaid after forty-five (45) Days from receipt by the City shall accrue simple interest at the rate of 10% per annum (or the maximum interest rate allowed by applicable law, whichever is less), from the 46th day after receipt by the City through the day the City mails payment to the Contractor.

Disputed Applications for Payment

Paragraph 4.5. If the City, in good faith, disputes any Application for Payment in whole or in part, the City shall notify Contractor of the dispute within the time required for payment and shall timely pay any undisputed portion. Interest shall not accrue on the amounts disputed in good faith.

City Payment Does Not Constitute Waiver

Paragraph 4.6. The City payment of an Application for Payment shall not prevent it from later filing claims against Contractor or waive its rights to recover money previously paid to Contractor. Without limiting the generality of the preceding sentence, the City may recover any sums paid to Contractor by mistake of law or of fact.

SECTION B. LIENS AND CLAIMS

Contractor's Obligations Concerning Liens and Claims

Paragraph 4.7. Contractor shall pay all valid claims for its labor, materials, services, supplies, and products as they become due. Whether a claim is valid or invalid, no lien, privilege, charge, or similar encumbrance shall become fixed upon the City lands, fixtures, improvements, or other property because of Contractor's failure to pay for goods or services provided for hereunder. After being notified of the existence of such claims, charges, liens, privilege, or encumbrances, Contractor agrees to take all necessary steps to obtain the release of such lien, privilege, or encumbrance.

Paragraph 4.8. If Contractor fails or refuses to pay its claims or indebtedness, then the City shall have the right to pay any such claims or indebtedness out any money due or to become due to Contractor under this Agreement; provided, however, the City shall not pay any such claim or indebtedness as long as Contractor is actively contesting it and has taken all actions necessary (including the posting of a bond or security if

appropriate) to protect the City's property interests and the interests of other Persons in that same property.

Paragraph 4.9. Before the City pays any Application for Payment, the City may require Contractor to certify that there are no unsatisfied claims for labor, materials, equipment, supplies, or products.

ARTICLE V. RISK MANAGEMENT

SECTION A. GENERAL INDEMNIFICATION

Release, Defense, and Indemnity

Paragraph 5.1. To the fullest extent permitted by law, Contractor shall indemnify and hold harmless City and its officers, directors, employees, agents, consultants and subcontractors of each and any of them from and against all claims, costs, losses, and damages (including but not limited to all fees and charges of engineers, architects, attorneys, and other professionals and all court or arbitration or other dispute resolution costs) arising out of or relating to the performance of the Work, provided that any such claim, cost, loss, or damage is attributable to bodily injury, sickness, disease, or death, or to injury to or destruction of tangible property (other than the Work itself), including the loss of use resulting therefrom but only to the extent caused by any negligent act or omission of Contractor, any subcontractor, any supplier, or any individual or entity directly or indirectly employed by any of them to perform any of the Work or anyone for whose acts any of them may be liable.

Paragraph 5.2. Contractor agrees to release, protect, defend, indemnify, and hold harmless the City or any of its officers, directors, employees, agents, consultants and subcontractors from and against any and all claims (including claims of Third Parties and claims of spouses, heirs, survivors, legal representatives, successors and assigns) of Contractor, any subcontractor, any supplier, or any individual or entity directly or indirectly employed by any of them to perform any of the Work for personal injury, illness, death, property (whether real or person, owned or leased) damage) and loss arising out of or resulting from the performance of this Agreement suffered by Contractor **EVEN IF THE CLAIMS ARE CONTRIBUTED TO OR CAUSED BY THE SOLE, JOINT, COMPARATIVE, CONCURRENT, ACTIVE OR PASSIVE NEGLIGENCE OF ANY MEMBER(S) OF THE CITY.**

The release, protection, defense, indemnity and hold harmless obligations assumed by Contractor, and the limitations afforded the City, in this paragraph include any liability for employment discrimination, medical, compensation, or other benefits owed to employees of Contractor as a result of the direct employment relationship of such individuals with a member of Contractor even if such individuals are determined to be the borrowed or statutory employee of any member(s) of the City.

The indemnities in Paragraph 5.2 of this Agreement shall only be effective to the maximum extent permitted by the applicable law, either legislative enactment or a controlling judicial decision. If such existing or future law limits in any way the extent to which indemnification may be provided to an indemnity that is negligent, solely negligent, or otherwise at fault and, notwithstanding the choice of law provision set forth herein, such law is applicable to interpretation of this Agreement, then this Agreement shall automatically be amended to provide that the indemnification provided hereunder shall extend only to the maximum extent permitted by such law. The liability of the City is limited due its status as a political subdivision of the State of Missouri.

Paragraph 5.3. For the purpose of Article V, the phrase “arising from or resulting from the performance of this Agreement” shall be broadly construed to include, but not be limited to, not only formal work, but also any occurrences at the work site, including transportation to and from the work (other than personal or public transportation to the work site), breaks of all kinds, including, without limitation, breaks for meals and/or rest, horseplay of all kinds, or volunteering of all kinds to assist others in their work.

Indemnity for Removal of Liens

Paragraph 5.4. Should the Contractor fail to fulfill its obligations under Article IV Section B concerning removal of liens, privileges or encumbrances on the property of any resident(s) of the City or property of the City arising out of performance under this Agreement, Contractor agrees to release, protect, defend, indemnify, and hold harmless the City for its direct costs actually incurred in removing such lien, privilege or encumbrance, should the City decide to proceed with removal.

Limitation on Damages

Paragraph 5.5. Contractor agrees that no resident(s) of the City will be responsible for and specifically agrees to release, defend, indemnify, and hold harmless the residents of the City, Mayor, City Council, employees, and agents from any and all liability for indirect, special, incidental, consequential, punitive or exemplary damages suffered by any employee(s) of Contractor.

SECTION B. INSURANCE

Basic Insurance Coverage

Paragraph 5.6. The Contractor and all subcontractors shall support its indemnity obligations by furnishing liability insurance coverage of the types set forth.

Comprehensive General Liability and Bodily Injury

Including Death: \$1,000,000 each person
 \$3,000,000 each occurrence

Property Damage: \$3,000,000 each occurrence
 \$3,000,000 aggregate

Comprehensive Automobile Liability, Bodily Injury

Including Death: \$1,000,000 each person
 \$3,000,000 each occurrence

Property Damage: \$3,000,000 each accident

Owner's Protective Bodily Injury

Including Death: \$1,000,000 each occurrence
 \$1,000,000 each occurrence

Property Damage: \$1,000,000 each occurrence
 \$1,000,000 aggregate

Workers Compensation

The Contractor shall procure and shall maintain during the term of the Agreement, Workers' Compensation insurance for all of its employees to be engaged and perform work under the Agreement, and in case any such work is sublet, the Contractor shall require the subcontractor similarly to provide Workers' Compensation Insurance for all such employees to be engaged in such work, unless such employees are covered by the protection afforded by the Contractor's Workers Compensation Insurance. In the event any class of employees engaged in hazardous work under the Agreement is not protected under the Workers' Compensation Statute, the Contractor shall provide, and shall cause such subcontractor to provide, adequate Employer's Liability Insurance for the protection of its employees not otherwise protected.

The insurer shall agree to waive all rights of subrogation against the City, its officers, officials, employees and volunteers for losses arising from work performed by the Contractor for the City.

In full compliance with the Worker's Compensation Act of the State of Missouri and Employer's Liability Coverage the minimum amount of insurance shall be \$1,000,000.00 per occurrence.

Insurance Endorsements and Provisions

Paragraph 5.7. Prior to commencing to Work under this Agreement, Contractor shall obtain a waiver of subrogation form from its insurers on the policies required in favor of the City.

Paragraph 5.8. All such insurance coverage required under this Agreement shall name the City and Owner's Representative as an additional insured.

Paragraph 5.9. Have such policies contain or be endorsed to contain a severability of interest provision so that each insured shall be treated separately under the policy so that the insurer may not deny enforcement based on the conduct or omissions of another insured; provided, however, this provision shall not cause any insurer or underwriter to pay more than the limits of the insurance coverage provided;

- Be primary over any insurance coverage maintained by the City;
- Be maintained in full force and effect during the term of this Agreement; and
- Contain provisions stating that such policies shall not be materially changed or cancelled without thirty (30) Days prior written notice having first been furnished to the City.

Certificates of Insurance

Paragraph 5.10. Contractor and all Subcontractors agree that prior to commencing any of the Work under this Agreement; they shall have their insurance carrier furnish the City a certificate or certificates of insurance and endorsement page(s) evidencing insurance coverage in accordance with the requirements identified herein. Acceptance by the City of a certificate or certificates of insurance and/or endorsement page(s) showing coverage not in compliance with the insurance requirements of this Agreement shall not relieve Contractor or Subcontractor(s) from its obligations under this Agreement.

Performance Bond and Labor and Material Payment Bond

Paragraph 5.11. Contractor shall furnish with the executed Agreement a Performance and Payment Bonds, each in an amount at least equal to the Contract Price of the Agreement as security for the faithful performance and payment of all Contractor's obligations under the Contract Documents, and also a Labor and Material Payment Bond in an amount at least equal to the Contract Price as security for the payment of all persons performing labor on the project under this Contract and furnishing materials in connection with this Contract. The Performance bond and the Labor and Material Payment Bond may be in separate instruments, however, if combined into one the amount shall be for two hundred percent of the Contract Sum. The City will hold the Bonds for the duration of the Contract, as security for faithful performance and payment of all obligations under the Contract Documents.

Paragraph 5.12. Shall use the Performance Bond forms contained in the contract documents.

Paragraph 5.13. All Bonds signed by an agent must be accompanied by a certified copy of agent's authority to act. Only surety companies authorized to do business in, and having an agent for services in the State of Missouri will be acceptable.

Paragraph 5.14. If the Surety on any Bonds furnished by the Contractor is declared bankrupt or becomes insolvent or its right to do business is terminated in the state where the project is located or it ceases to meet the requirements of the preceding paragraph, the Contractor shall substitute another Bond and Surety, both of which must be acceptable to the City before continuing the Work.

Severability

Paragraph 5.15. If any part of Article V contravenes any applicable statutes, regulations, rules, or common law requirements, then, to the extent and only to the extent of such contravention, such part shall be severed from this Article V and deemed nonbinding while all other parts of this Article V shall remain binding.

ARTICLE VI.

LEGAL ADMINISTRATION

SECTION A. COMPLIANCE WITH LAWS AND REGULATIONS

General Legal Compliance

Paragraph 6.1. Contractor shall comply with all applicable local, state and federal ordinances, statutes, laws, rules and regulations applicable to the Agreement as well as other regulations and restrictive covenants of the City.

If the Contractor discovers any provisions in the Agreement which is contrary or inconsistent with any law, ordinance, or regulation, it shall immediately report same in writing to the City.

Paragraph 6.2. Contractor shall be held to comply with all requirements of the Prevailing Wage Law of the State of Missouri, and shall forfeit as a penalty to the state, county, city, town district or other political subdivision on whose behalf the Contract is made or awarded, one hundred dollars (\$100.00) for each workman employed, for each calendar day, or portion thereof, such workman is paid less than the said stipulated rates for any work done under this Contractor, by him/her or by any subcontractor under him/her.

Paragraph 6.3. Contractor shall affirm by sworn affidavit that he/she has enrolled and participated in a federal work authorization program with respect to its employees who work in connection with the contracted services and to sign the affidavit affirming

that Contractor does not knowingly employ any person who is an unauthorized alien in connection with the Contract. Such affidavit shall be required as a condition of this Contract prior to or at the time of execution of this Contract, and Contractor shall provide documentation for the program.

SECTION B. GOVERNING LAW AND DISPUTE RESOLUTION

Paragraph 6.4. The Agreement shall be governed by, construed, and enforced in accordance with the laws of the State of Missouri. The Agreement is performable in Franklin, County, Missouri, and the Parties agree that venue for any dispute under the Agreement shall be Franklin County. Any Party, who is the prevailing Party in any legal proceeding brought under or in relation to the Agreement shall be entitled to recover court costs and reasonable attorney's fees from the non-prevailing Party.

SECTION C. MISCELLANEOUS

Severability

Paragraph 6.5. If any part of this Agreement contravenes any applicable statutes, regulations, rules, or common law requirements, then, to the extent and only to the extent of such contravention, such part shall be severed from this Agreement and deemed nonbinding while all other parts of this Agreement shall remain binding, so long as the material purposes of this Agreement can be determined and effectuated.

Singular and Plural

Paragraph 6.6. Reference to one gender includes a reference to the other gender.

Headings

Paragraph 6.7. The headings, sub-headings, and other subdivisions of this Agreement are inserted for convenience only. The Parties do not intend them to be an aid in legal construction.

Counterpart Execution

Paragraph 6.8. This Agreement may be executed in any number of counterparts, and each such counterpart shall be deemed an original of this Agreement for all purposes. No Party shall be bound to this Agreement unless and until all Parties have executed a counterpart.

Binding Authority

Paragraph 6.9. Each of the individuals executing this Agreement represents that he or she has full right and authority to execute this instrument on behalf of the City or Contractor, as the case may be, and to bind such Party. If the Person executing this Agreement has a title that includes the term "Manager," "Director," or "Vice President," then the Parties agrees that such Person has apparent authority to execute this Agreement and bind the Party. If such Person executes this Agreement on behalf of a Party, the other Party is not required to obtain a power of attorney, delegation of authority, or corporate resolution evidencing such authority.

Entirety of Contract

Paragraph 6.10. The Agreement embodies the entire contract between Parties.

Waiver

Paragraph 6.11. Failure to exercise any option to terminate shall not constitute a waiver of the right to exercise the same in the event of any subsequent default. A waiver of any breach of any provision of the Agreement shall not constitute or operate as a waiver of any breach of such provision or any other provisions, nor shall any failure to enforce any provision hereof operate as a waiver of such provisions or any other provision. The failure of the City at any time to enforce or to object to a failure or refusal to perform any terms, condition, or covenant of the Agreement, or to exercise any option herein given, or to require at any time performance by the Contractor of any term, condition, or covenant hereof, shall in no way constitute a waiver of any subsequent breach, or effect the validity of the Agreement or any part hereof or the right of the City thereafter to enforce the same, but shall apply only to the specific instance to which the failure to enforce is directed.

Approvals

Paragraph 6.12. All approvals or consents required or permitted pursuant to the Agreement shall be in writing in order to be considered valid and effective.

IN WITNESS WHEREOF, the parties hereto have executed this Agreement as of the date first above written.

CITY OF WASHINGTON

By _____
James D. Hagedorn, Mayor

(SEAL)

ATTEST:

Sherri Klekamp, City Clerk

CONTRACTOR

By _____
"Contractor"
Title _____

(SEAL)

ATTEST:

Title:

BILL NO. _____ INTRODUCED BY _____

ORDINANCE NO. _____

AN ORDINANCE AUTHORIZING AND DIRECTING THE CITY OF WASHINGTON, MISSOURI TO ENTER INTO A SALES CONTRACT WITH CLARK EQUIPMENT D/B/A BOBCAT COMPANY FOR THE PURCHASE OF A BOBCAT TOOLCAT UW56 UTILITY WORK MACHINE WITH ATTACHMENTS

Be It Ordained by the Council of the City of Washington, Missouri, as follows:

SECTION 1: The Mayor is hereby authorized to execute a Sales Contract with Clark Equipment d/b/a Bobcat Company in an amount totaling Seventy Two Thousand Nine Hundred Ninety Five Dollars and Fifty Three Cents (\$72,995.53) for the purchase of a new Bobcat Toolcat UW56 and attachments, which includes the trade in of a 2016 Toolcat in the amount of Twenty Thousand Dollars and No Cents (\$20,000.00). A copy of said sales contract is attached hereto and marked as Exhibit A.

SECTION 2: All ordinances or parts of ordinances in conflict herewith are hereby repealed.

SECTION 3: This ordinance shall take effect and be in full force from and after it's passage and approval.

Passed: _____

ATTEST: _____

President of City Council

Approved: _____

ATTEST: _____

Mayor of Washington, Missouri

**Exhibit A
SALES CONTRACT**

This Sales Contract, made and entered into this 5th day of February, 2024, by and between Clark Equipment Company dba Bobcat Company, Government Sales, 250 E. Beaton Drive, West Fargo, ND 58078, herein referred to as "Seller", and the City of Washington, MO., a municipal corporation hereinafter referred to as "City".

WITNESSETH: Whereas, Seller was the best low bid received for furnishing of one (1) Bobcat Toolcat UW56 Utility Work Machine and attachments equipped as stated in the bid.

NOW THEREFORE, THE PARTIES HERETO AGREE AS FOLLOWS:

1. Seller agrees to provide to the City one (1) Bobcat Toolcat UW56 Utility Work Machine and attachments and/or alternate bids in the manner set forth in the contract documents, for payment in the total sum of Seventy Two Thousand Nine Hundred Ninety Five Dollars and Fifty Three Cents (\$ 72,995.53.00).

2. The contract documents shall consist of the following:

- A. This Contract
- B. Signed copy of Ordinance
- C. General Specification and Bid

This contract, together with the other documents enumerated in this paragraph, forms the contract between the parties.

These documents are as fully a part of the contract as if attached hereto or repeated herein.

3. This agreement shall be construed or determined according to the laws of the State of Missouri.

IN TESTIMONY WHEREOF, Seller has hereunto set its hand, and the City of Washington executes this contract the day and year first written.

SELLER:

CITY:

BY: _____
Company Representative

BY: _____
Mayor – Washington, MO

ATTEST: _____
City Clerk



February 5, 2024

Honorable Mayor and City Council
City of Washington
405 Jefferson Street
Washington, MO 63090

RE: Bid Recommendation – Toolcat Utility Work Machine Replacement

Honorable Mayor and City Council,

As you may be aware, before making a determination that a particular piece of equipment should be replaced, staff will annually review and analyze the equipment to determine the current condition and the need for replacement. In doing so, it was determined the 2016 Toolcat machine and bucket needs replacing due to usage hours, age and ongoing repairs. This machine is used daily. As such, the Department identified the need to replace the Toolcat in the 2023-2024 budget. The new machine will include some attachments such as a new heavy duty bucket, pallet forks and a clod buster attachment (demo model). In order to include some of the attachments in the purchase, staff worked diligently with the dealer to determine the best trade in value for the old machine. The new Toolcat would be purchased under the state equipment contract, which the Department has used on past equipment purchases.

Accordingly, staff recommends that Council consider Clark Equipment's (dba Bobcat Co.) bid in the amount of \$72,995.53 for the new Toolcat, attachments and the trade in discount of (\$20,000) for the old Toolcat. This amount is under the budgeted amount of \$74,000.00, which was approved in the 2023-2024 Parks and Recreation budget.

As always, if you have any questions, concerns or would like additional information, please feel free to contact me prior to the Council Meeting.

Respectfully,

Wayne Dunker

Wayne Dunker MA, CPRP
Director of Parks & Recreation



Product Quotation
 Quotation Number: **ZW301104**
 Quote Sent Date: **Jan 19, 2024**
 Expiration Date: **Feb 18, 2024**

Your Bobcat Contact
Zachary Wollak
 Phone:
 E-mail: zachary.wollak@doosan.com

Your Customer Contact

Deliver to
CITY OF WASHINGTON PARKS
DEPT
 1220 S SHORE DR
 WASHINGTON, MO, 63090

Cody Bell
Bobcat of St. Louis, Valley Park, MO
 401 WEST OUTER RD
 VALLEY PARK, , 63088-2031

Bill to
CITY OF WASHINGTON PARKS
DEPT
 1220 S SHORE DR
 WASHINGTON, MO, 63090

| Item Name | Item Number | Quantity | Price Each | Total |
|--|---------------|----------|--|-----------|
| Bobcat UW56 Standard Equipment: Adjustable Vinyl Seats All-Wheel Steer Automatically Activated Glow Plugs Auxiliary Hydraulics Variable Flow with dual direction detent Beverage Holders Bob-Tach Boom Float Cargo Box Support Cruise Control Speed Management Enclosed Cab with HVAC Dual Port USB charger Lower Engine Guard Limited Slip Transaxle Engine and Hydraulic Monitor with Shutdown Front LED Work Lights Full-time Four-Wheel Drive | M1225 | 1 | 63,825.60 | 63,825.60 |
| | | | Horsepower Management Roll Over Protective Structure (ROPS) . Meets Requirements of SAE-J1040 & ISO 3471 Falling Object Protective Structure (FOPS) . Meets Requirements of SAE-J1043 & ISO3449, Level I Dome Light Hydraulic Dump Box Instrumentation: Standard 5" Display with Keyless Start, Engine Temperature and Fuel Gauges, Hour meter, RPM and Warning Indicators. Includes maintenance interval notification, fault display, job codes, quick start, and security lockouts. Joystick, Manually Controlled with Lift Arm Float Lift Arm Support Parking Brake, automatic Power Steering with Tilt Steering Wheel Radiator Screen Rear Receiver Hitch Seat Belts, Shoulder Harness Spark Arrestor Muffler Suspension, 4-wheel independent Tires: 27 x 10.5-15 (8 ply), Lug Tread Toolcat Interlock Control System (TICS) Two-Speed Transmission Machine Warranty: 12 Months, unlimited hours Bobcat Engine Warranty: Additional 12 Months or total of 2000 hours after initial 12 month warranty | |
| Deluxe Road Package <i>Included:</i> Deluxe Road Package includes: Backup Alarm, Turn Signals, Flashers, Tail Lights, Brake Lights, Rear view mirror, Side Mirrors, Horn, Rear work lights, and headlights | M1225-P01-C01 | 1 | 2,364.00 | 2,364.00 |
| Attachment Control | M1225-R08-C02 | 1 | 204.00 | 204.00 |

7d

| | | | | |
|---|---------------|---|----------|------------------|
| Engine Block Heater | M1225-A01-C02 | 1 | 116.00 | 116.00 |
| Heavy Duty Battery | M1225-R07-C02 | 1 | 80.00 | 80.00 |
| High Flow Package | M1225-R03-C02 | 1 | 1,388.80 | 1,388.80 |
| Interior Trim | M1225-A01-C04 | 1 | 172.00 | 172.00 |
| Power Bob-Tach | M1225-R14-C03 | 1 | 920.00 | 920.00 |
| Radio Option | M1225-R15-C02 | 1 | 452.00 | 452.00 |
| Rear View Camera | M1225-R20-C01 | 1 | 300.00 | 300.00 |
| Traction Control | M1225-R16-C02 | 1 | 484.00 | 484.00 |
| 29 X 12.5 Turf Tires | M1225-R05-C05 | 1 | 688.00 | 688.00 |
| 68" Heavy Duty Bucket | 7272679 | 1 | 1,301.12 | 1,301.12 |
| Bolt-On Cutting Edge, 68" | 6718006 | 1 | 278.01 | 278.01 |
| 5.5K Severe Duty Pallet Fork Frame | 7294332 | 1 | 712.88 | 712.88 |
| 48" 5.5K Severe Duty Pallet Fork Teeth | 6541518 | 1 | 506.92 | 506.92 |
| Floorboard Riser | 7434156 | 1 | 604.35 | 604.35 |
| Rear Window Guard | 7150926 | 1 | 966.09 | 966.09 |
| Suspension Seat Kit | 7137285 | 1 | 1,485.41 | 1,485.41 |
| Rotating Beacon | 7424195 | 1 | 223.60 | 223.60 |
| Total for Bobcat UW56 | | | | 77,072.78 |

| | |
|---------------------------------|------------------|
| Quote Total - USD | 77,072.78 |
| Dealer P.D.I. | 150.00 |
| Freight Charges | 1,400.00 |
| Destination Charges | 214.00 |
| Dealer Assembly Charges | 658.75 |
| Discount | |
| 2016 TOOLCAT 5600 S/N AHG813426 | -20,000.00 |
| Quote Total - USD | 59,495.53 |

Comment:

*Plus applicable taxes. IF Tax Exempt, please include Tax Exempt Certificate with the order.

*Prices per the NASPO Construction Equipment Master Agreement OK-SW-192.

<https://www.naspo.valuepoint.org/portfolio/construction-equipment-2018-2023/clark-equipment-company/>

State and Contract Number Summary:

AK - N2019CE0002

CA - 52000C

IA - OK-SW-192

KS - OK-SW-192

MO - CC190249002

NE - 15336

NM - 90-000-19-00068AA

OK - SW192

RI - OK-SW-192

SD - 17286

UT - PA3043

WI - 505ENT-O22-CONSTREQUIP-03.

7d

*All orders should include 1) Accounts Payable Contact and email address, 2) W9 with correct legal entity name, and 3) Bill to Address.

*Orders may be placed with the contract holder or authorized dealer as allowed by the terms and conditions of the contract. *A Copy of all orders must be provided to Heather.Messmer@Doosan.com.

*Contact Holder Information: Clark Equipment Company dba Bobcat Company, Govt Sales, 250 E Beaton Drive, West Fargo, ND 58078. TID# 38-0425350.

*Payment Terms: Net 60 Days. Credit cards accepted.

*Remittance address: Clark Equipment Company d/b/a Bobcat Company, P. O. Box 74007382, Chicago, IL 60674-7382

*Questions can be submitted via email to Jesse.Rheault@doosan.com or by phone at: 1-800-965-4232.

| | |
|--|-----------------------|
| Customer Acceptance: | |
| Quotation Number: ZW301104 | Purchase Order: _____ |
| Authorized Signature: | |
| Print: _____ | Sign: _____ |
| Date: _____ | Email: _____ |
| Addresses: | |
| Delivery Address: _____ | |
| Billing Address (if different from ship to): _____ | |
| Tax Exempt: Y <input type="checkbox"/> / N <input type="checkbox"/> | |
| Exempt in the State of: _____ | |
| Tax Exempt ID: | |
| Federal: _____ | |
| State: _____ | |
| Expiration Date: _____ | |



Product Quotation
 Quotation Number: **CB301273**
 Quote Sent Date: **Jan 19, 2024**
 Expiration Date: **Feb 18, 2024**

Prepared By
Cody Bell
 Phone: 314-614-1944
 Email: cbell@bobcatofstl.com

Customer
CITY OF WASHINGTON PARKS
DEPT
 1220 S SHORE DR
 WASHINGTON, MO, 63090
 Phone: +1 636 390 1080

Contact

Dealer
Bobcat of St. Louis, Valley Park, MO

| Item Name | Item Number | Quantity | Price Each | Total |
|---|-------------|----------|------------|------------------|
| BURLY ATTACHMENTS USED CLOD BUCKET | 1 | 1 | 13,500.00 | 13,500.00 |
| Total for BURLY ATTACHMENTS USED CLOD BUCKET | | | | 13,500.00 |
| Quote Total - USD | | | | 13,500.00 |
| Sales total before Taxes | | | | 13,500.00 |
| Taxes | | | | 0.00 |
| Quote Total - USD | | | | 13,500.00 |

Customer Acceptance:
 Quotation Number: **CB301273** Purchase Order: _____

Authorized Signature:
 Print: _____ Sign: _____

Date: _____ Email: _____ Tax Exempt: Y / N

7d

BILL NO. _____ INTRODUCED BY _____

ORDINANCE NO. _____

AN ORDINANCE AUTHORIZING AND DIRECTING THE CITY OF WASHINGTON, MISSOURI TO ENTER INTO A SALES CONTRACT WITH TRUCK CENTERS, INC. FOR THE PURCHASE OF A 2-TON FREIGHTLINER 108SD PLUS DUMP TRUCK

Be It Ordained by the Council of the City of Washington, Missouri, as follows:

SECTION 1: The Mayor is hereby authorized to execute a Sales Contract with Truck Centers, Inc. in an amount totaling Ninety Seven Thousand, Eight Hundred Thirty Seven Dollars, and Zero Cents (\$97,837.00) for the purchase of a 2-Ton Freightliner 108SD Plus Dump Truck. A copy of said sales contract is attached hereto and marked as Exhibit A.

SECTION 2: All ordinances or parts of ordinances in conflict herewith are hereby repealed.

SECTION 3: This ordinance shall take effect and be in full force from and after it's passage and approval.

Passed: _____

ATTEST: _____

President of City Council

Approved: _____

ATTEST: _____

Mayor of Washington, Missouri

Exhibit A

SALES CONTRACT

This Sales Contract made and entered into this _____ day of _____, 2024, by and between Truck Centers, Inc., 2280 Formosa Road, Troy, Illinois, 62294, herein referred to as "Seller", and the City of Washington, Missouri, a municipal corporation hereinafter referred to as "City".

WITNESSETH: Whereas Seller was the best low bid received for furnishing of one 2-Ton Freightliner 108SD Plus Dump Truck.

NOW THEREFORE, THE PARTIES HERETO AGREE AS FOLLOWS:

Seller agrees to provide to the City with one (1) 2-Ton Freightliner 108SD Plus Dump Truck for payment in the total sum of Ninety Seven Thousand, Eight Hundred Thirty Seven Dollars and Zero Cents (\$97,837.00).

The contract documents shall consist of the following:

- A. This Contract
- B. Signed copy of Ordinance
- C. General Specification and Bid

This contract, together with the other documents enumerated in this paragraph, forms the contract between the parties.

These documents are as fully a part of the contract as if attached hereto or repeated herein.

This agreement shall be construed or determined according to the laws of the State of Missouri.

IN TESTIMONY WHEREOF, Seller has hereunto set its hand, and the City of Washington executes this contract the day and year first written.

SELLER:

CITY:

BY: _____
Company Representative

BY: _____
Mayor – Washington, Missouri

ATTEST: _____
City Clerk



January 30, 2024

Honorable Mayor and City Council
City of Washington
405 Jefferson Street
Washington, MO 63090

RE: Recommendation – Use of MoDOT State Bid for the purchase of a 2-Ton Dump Truck with Snowplow & Salt Spreader

Honorable Mayor and City Council,

As you may be aware, before making a determination that a particular piece of equipment needs to be purchased, staff will annually review and analyze the equipment to determine the current requirement and the need for purchases. The new 2025 2-Ton Dump Truck with Snowplow & Salt Spreader is in the 2023-2024 budget in the amount of \$180,000. This would replace Truck #54 a 2010 International truck with Snowplow & Spreader.

Staff found that the MoDOT State Bid # 605CO23002393 would give the city the best pricing for this truck, from Truck Centers Inc. Troy IL. & the bed, snowplow & salt spreader from Woody's Municipal Supply Co., Edwardsville, IL.

The truck quote from Truck Centers Inc., is \$97,837, and we budgeted \$100,000. The Bed, Snowplow, and Spreader quote From Woody's Municipal Supply Co., is \$71,868, and we budgeted \$80,000. There will be separate contracts and ordinances for both companies due to there being a longer wait time for the bed, plow, & spreader, but they are both under the same MoDOT State Bid.

- I am recommending the New Freightliner 108S truck at \$97,837. This truck will replace truck #54 a 2010 International snowplow truck, with 35,200 miles. Although the miles are low, the truck has had numerous mechanical and corrosion issues. This also meets the 15-year equipment replacement recommendations. We will sell the 2010 International Truck #54 with plow and spreader together.
- I am also recommending the new Galion 430U SMS Bed, and the Buyers brand snowplow and salt spreader, at \$71,868, to replace the 2010 equipment,

As always, if you have any questions, concerns or would like additional information, please feel free to contact me prior to the City Council Workshop Meeting.

Respectfully,

Tony Bonastia
Street Superintendent
Washington MO

te

Prepared for:
Ryan Reed
MISSOURI DOT
830 MoDOT Drive
605CO23002393
JEFFERSON CITY, MO 65109
Phone: (573) 751-3685

Prepared by:
Matt Pace
TRUCK CENTERS, INC.
2280 FORMOSA RD.
TROY, IL 62294
Phone: 618-667-3454

A proposal for
MISSOURI DOT

Prepared by
TRUCK CENTERS, INC.
Matt Pace

Nov 30, 2023

Freightliner 108SD Plus



Components shown may not reflect all spec'd options and are not to scale

Application Version 11.9.305
Data Version PRL-28D.022
City of Washington MY25 108SD PLUS
37K D...



11/30/2023 5:54 PM

Page 1 of 22

7e

Prepared for:
 Ryan Reed
 MISSOURI DOT
 830 MoDOT Drive
 605CO23002393
 JEFFERSON CITY, MO 65109
 Phone: (573) 751-3685

Prepared by:
 Matt Pace
 TRUCK CENTERS, INC.
 2280 FORMOSA RD.
 TROY, IL 62294
 Phone: 618-667-3454

Q U O T A T I O N

108SD PLUS CONVENTIONAL CHASSIS

SET BACK AXLE - TRUCK
 CUM L9 300 HP @ 2200 RPM; 2200 GOV RPM, 860 LB-FT @ 1200 RPM
 ALLISON 3500 RDS AUTOMATIC TRANSMISSION WITH PTO PROVISION
 RS-23-160 23,000# R-SERIES SINGLE REAR AXLE
 23,000# FLAT LEAF SPRING REAR SUSPENSION WITH HELPER AND RADIUS ROD
 DETROIT DA-F-14.7-3 14,700# FF1 71.5 KPI/3.74 DROP SINGLE FRONT AXLE
 14,600# TAPERLEAF FRONT SUSPENSION

108 INCH BBC FLAT ROOF ALUMINUM CONVENTIONAL CAB
 3825MM (151 INCH) WHEELBASE
 NO FIFTH WHEEL
 7/16X3-9/16X11-1/8 INCH STEEL FRAME (11.11MMX282.6MM/0.437X11.13 INCH) 120KSI
 1650MM (65 INCH) REAR FRAME OVERHANG
 TEM TO EVALUATE AND INSTALL FRAME RAIL REINFORCEMENT AS NEEDED FOR FRONT FRAME MOUNTED EQUIPMENT

| | | PER UNIT | | TOTAL |
|----------------------------------|-----------------------------|------------------|-----------|---------------|
| VEHICLE PRICE | TOTAL # OF UNITS (1) | \$ 97,607 | \$ | 97,607 |
| EXTENDED WARRANTY | | \$ 230 | \$ | 230 |
| DEALER INSTALLED OPTIONS | | \$ 0 | \$ | 0 |
| CUSTOMER PRICE BEFORE TAX | | \$ 97,837 | \$ | 97,837 |

TAXES AND FEES

| | | | | |
|----------------|----|---|----|---|
| TAXES AND FEES | \$ | 0 | \$ | 0 |
| OTHER CHARGES | \$ | 0 | \$ | 0 |

TRADE-IN

| | | | | |
|--------------------|----|-----|----|-----|
| TRADE-IN ALLOWANCE | \$ | (0) | \$ | (0) |
|--------------------|----|-----|----|-----|

| | | | | |
|--------------------|--|----------------------------|------------------|------------------|
| BALANCE DUE | | (LOCAL CURRENCY) \$ | \$ 97,837 | \$ 97,837 |
|--------------------|--|----------------------------|------------------|------------------|

COMMENTS:

Projected delivery on ___ / ___ / ___ provided the order is received before ___ / ___ / ___.

APPROVAL:

Please indicate your acceptance of this quotation by signing below:

Customer: X _____ Date: ___ / ___ / ___.

PRICE MAY CHANGE DEPENDING ON MANUFACTURER SURCHARGES AND MODEL YEAR

DEPENDING ON FACTORY BUILD SLOTS AND PARTS RESTRAINTS THERE IS NO GUARANTEE ON BUILD DATE



Te

Prepared for:
Ryan Reed
MISSOURI DOT
830 MoDOT Drive
605CO23002393
JEFFERSON CITY, MO 65109
Phone: (573) 751-3685

Prepared by:
Matt Pace
TRUCK CENTERS, INC.
2280 FORMOSA RD.
TROY, IL 62294
Phone: 618-667-3454

Daimler Truck Financial

Financing that works for you.

See your local dealer for a competitive quote from Daimler Truck Financial, or contact us at Information@dtfoffers.com.

Daimler Truck Financial offers a variety of finance, lease and insurance solutions to fit your business needs. For more information about our products and services, visit our website at www.daimler-truckfinancial.com.



Prepared for:
 Ryan Reed
 MISSOURI DOT
 830 MoDOT Drive
 605CO23002393
 JEFFERSON CITY, MO 65109
 Phone: (573) 751-3685

Prepared by:
 Matt Pace
 TRUCK CENTERS, INC.
 2280 FORMOSA RD.
 TROY, IL 62294
 Phone: 618-667-3454

S P E C I F I C A T I O N P R O P O S A L

| Data Code | Description | Weight Front | Weight Rear | Retail Price |
|------------------------------|---|--------------|-------------|--------------|
| Price Level | | | | |
| PRL-28D | SD PRL-28D (EFF:MY25 ORDERS) | | | STD |
| Data Version | | | | |
| DRL-022 | SPECPRO21 DATA RELEASE VER 022 | | | N/C |
| Vehicle Configuration | | | | |
| 001-176 | 108SD PLUS CONVENTIONAL CHASSIS | 6,829 | 3,748 | \$133,998.00 |
| 004-225 | 2025 MODEL YEAR SPECIFIED | | | STD |
| 002-004 | SET BACK AXLE - TRUCK | | | STD |
| 019-006 | TRAILER TOWING PROVISION AT END OF FRAME WITH SAE J560 | 10 | 10 | \$1,025.00 |
| 003-001 | LH PRIMARY STEERING LOCATION | | | STD |
| General Service | | | | |
| AA1-003 | TRUCK/TRAILER CONFIGURATION | | | N/C |
| AA6-002 | DOMICILED, USA (EXCLUDING CALIFORNIA AND CARB OPT-IN STATES) | | | N/C |
| 99D-027 | EPA EMISSIONS CERTIFICATION FOR REGISTRATION OUTSIDE CARB STATES - EPA CLEAN IDLE (INCLUDES 6X4 INCH LABEL ON LOWER FORWARD OF DRIVER DOOR) | | | N/C |
| AF2-998 | NO STATE/PROVINCE INITIAL REGISTRATION SELECTED | | | N/C |
| A85-010 | UTILITY/REPAIR/MAINTENANCE SERVICE | | | N/C |
| A84-1GM | GOVERNMENT BUSINESS SEGMENT | | | N/C |
| AA4-010 | DIRT/SAND/ROCK COMMODITY | | | N/C |
| AA5-002 | TERRAIN/DUTY: 100% (ALL) OF THE TIME, IN TRANSIT, IS SPENT ON PAVED ROADS | | | STD |
| AB1-008 | MAXIMUM 8% EXPECTED GRADE | | | STD |
| AB5-001 | SMOOTH CONCRETE OR ASPHALT PAVEMENT - MOST SEVERE IN-TRANSIT (BETWEEN SITES) ROAD SURFACE | | | STD |
| 995-1A0 | FREIGHTLINER SD VOCATIONAL WARRANTY | | | STD |
| A66-99D | EXPECTED FRONT AXLE(S) LOAD : 14600.0 lbs | | | |



7e

Prepared for:
 Ryan Reed
 MISSOURI DOT
 830 MoDOT Drive
 605CO23002393
 JEFFERSON CITY, MO 65109
 Phone: (573) 751-3685

Prepared by:
 Matt Pace
 TRUCK CENTERS, INC.
 2280 FORMOSA RD.
 TROY, IL 62294
 Phone: 618-667-3454

| Data Code | Description | Weight Front | Weight Rear | Retail Price |
|------------------------------|---|--------------|-------------|--------------|
| A68-99D | EXPECTED REAR DRIVE AXLE(S) LOAD : 23000.0 lbs | | | |
| A63-99D | EXPECTED GROSS VEHICLE WEIGHT CAPACITY : 37600.0 lbs | | | |
| A70-99D | EXPECTED GROSS COMBINATION WEIGHT : 40000.0 lbs | | | |
| Truck Service | | | | |
| AA3-018 | FRONT PLOW/END DUMP BODY | | | N/C |
| AF3-1W0 | HENDERSON | | | N/C |
| Tractor Service | | | | |
| AA2-005 | FLATBED TRAILER | | | N/C |
| AH6-001 | SINGLE (1) TRAILER | | | N/C |
| Engine | | | | |
| 101-3BN | CUM L9 300 HP @ 2200 RPM; 2200 GOV RPM, 860 LB-FT @ 1200 RPM | | | \$1,517.00 |
| Electronic Parameters | | | | |
| 79A-070 | 70 MPH ROAD SPEED LIMIT | | | N/C |
| 79B-000 | CRUISE CONTROL SPEED LIMIT SAME AS ROAD SPEED LIMIT | | | N/C |
| 79K-007 | PTO MODE ENGINE RPM LIMIT - 1100 RPM | | | N/C |
| 79P-002 | PTO RPM WITH CRUISE SET SWITCH - 700 RPM | | | N/C |
| 79Q-002 | PTO RPM WITH CRUISE RESUME SWITCH - 700 RPM | | | N/C |
| 79U-005 | PTO GOVERNOR RAMP RATE - 150 RPM PER SECOND | | | N/C |
| 79V-001 | FUEL DOSING OF AFTERTREATMENT ENABLED IN PTO MODE-CLEANS HYDROCARBONS AT HIGH TEMPERATURES ONLY | | | N/C |
| 79W-024 | CRUISE CONTROL BUTTON PTO CONTROL | | | N/C |
| 80G-002 | PTO MINIMUM RPM - 700 | | | N/C |
| 80J-002 | REGEN INHIBIT SPEED THRESHOLD - 5 MPH | | | N/C |
| 80S-003 | PTO 1, DASH SWITCH, ENGAGE BEFORE DRIVING | | | N/C |
| 80T-016 | PTO 2, NO SWITCH, TEM SUPPLIED REQUEST AND INTERLOCKS, WITH PTO CONNECTIONS, ENGAGE BEFORE DRIVING INTERLOCKS | | | N/C |
| 80V-003 | ENGINE MOUNT PTO, TEM SUPPLIED REQUEST, FOR PTO SPEED MODE, PERMANENTLY ENGAGED PTO | | | N/C |
| Engine Equipment | | | | |
| 99C-024 | EPA 2010/GHG 2024 CONFIGURATION | | | STD |



Prepared for:
 Ryan Reed
 MISSOURI DOT
 830 MoDOT Drive
 605CO23002393
 JEFFERSON CITY, MO 65109
 Phone: (573) 751-3685

Prepared by:
 Matt Pace
 TRUCK CENTERS, INC.
 2280 FORMOSA RD.
 TROY, IL 62294
 Phone: 618-667-3454

| Data Code | Description | Weight Front | Weight Rear | Retail Price |
|-----------|---|--------------|-------------|--------------|
| 13E-001 | STANDARD OIL PAN | | | STD |
| 105-001 | ENGINE MOUNTED OIL CHECK AND FILL | | | STD |
| 014-108 | SIDE OF HOOD AIR INTAKE WITH FIREWALL MOUNTED DONALDSON AIR CLEANER WITH SAFETY ELEMENT AND INSIDE/OUTSIDE AIR WITH SNOW DOOR | 10 | | \$562.00 |
| 124-1D7 | DR 12V 160 AMP 28-SI QUADRAMOUNT PAD ALTERNATOR WITH REMOTE BATTERY VOLT SENSE | | | STD |
| 292-235 | (2) DTNA GENUINE, FLOODED STARTING, MIN 2000CCA, 370RC, THREADED STUD BATTERIES | | | STD |
| 290-017 | BATTERY BOX FRAME MOUNTED | | | STD |
| 281-001 | STANDARD BATTERY JUMPERS | | | STD |
| 282-001 | SINGLE BATTERY BOX FRAME MOUNTED LH SIDE UNDER CAB | | | \$18.00 |
| 291-017 | WIRE GROUND RETURN FOR BATTERY CABLES WITH ADDITIONAL FRAME GROUND RETURN | | | STD |
| 289-001 | NON-POLISHED BATTERY BOX COVER | | | STD |
| 295-029 | POSITIVE AND NEGATIVE POSTS FOR JUMPSTART LOCATED ON FRAME NEXT TO STARTER | 2 | | \$88.00 |
| 306-015 | PROGRESSIVE LOW VOLTAGE DISCONNECT AT 12.3 VOLTS FOR DESIGNATED CIRCUITS | | | STD |
| 107-032 | CUMMINS TURBOCHARGED 18.7 CFM AIR COMPRESSOR WITH INTERNAL SAFETY VALVE | | | STD |
| 152-041 | ELECTRONIC ENGINE INTEGRAL SHUTDOWN PROTECTION SYSTEM | | | STD |
| 128-076 | CUMMINS ENGINE INTEGRAL BRAKE WITH VARIABLE GEOMETRY TURBO ON/OFF | 20 | | STD |
| 016-1C2 | RH OUTBOARD UNDER STEP MOUNTED HORIZONTAL AFTERTREATMENT SYSTEM ASSEMBLY WITH RH B-PILLAR MOUNTED VERTICAL TAILPIPE | 30 | 25 | \$816.00 |
| 28F-014 | ENGINE AFTERTREATMENT DEVICE, AUTOMATIC OVER THE ROAD REGENERATION AND VIRTUAL REGENERATION REQUEST SWITCH IN CLUSTER | | | STD |
| 239-026 | 10 FOOT 06 INCH (126 INCH+0/-5.9 INCH) EXHAUST SYSTEM HEIGHT | | | (\$3.00) |
| 237-1CR | RH CURVED VERTICAL TAILPIPE B-PILLAR MOUNTED ROUTED FROM STEP | | | N/C |
| 23U-001 | 6 GALLON DIESEL EXHAUST FLUID TANK | -35 | -10 | N/C |
| 30N-003 | 100 PERCENT DIESEL EXHAUST FLUID FILL | | | (\$17.00) |
| 23Y-001 | STANDARD DIESEL EXHAUST FLUID PUMP MOUNTING | | | STD |



7e

Prepared for:
 Ryan Reed
 MISSOURI DOT
 830 MoDOT Drive
 605CO23002393
 JEFFERSON CITY, MO 65109
 Phone: (573) 751-3685

Prepared by:
 Matt Pace
 TRUCK CENTERS, INC.
 2280 FORMOSA RD.
 TROY, IL 62294
 Phone: 618-667-3454

| Data Code | Description | Weight Front | Weight Rear | Retail Price |
|-----------|---|--------------|-------------|--------------|
| 43X-002 | LH MEDIUM DUTY STANDARD DIESEL EXHAUST FLUID TANK LOCATION | | | STD |
| 43Y-001 | STANDARD DIESEL EXHAUST FLUID TANK CAP | | | STD |
| 242-011 | ALUMINUM AFTERTREATMENT DEVICE/MUFFLER/TAILOPIPE SHIELD(S) | | | N/C |
| 273-058 | AIR POWERED ON/OFF ENGINE FAN CLUTCH | | | STD |
| 276-001 | AUTOMATIC FAN CONTROL WITHOUT DASH SWITCH, NON ENGINE MOUNTED | | | STD |
| 110-003 | CUMMINS SPIN ON FUEL FILTER | | | STD |
| 118-008 | COMBINATION FULL FLOW/BYPASS OIL FILTER | | | STD |
| 266-104 | 1115 SQUARE INCH ALUMINUM RADIATOR | | | STD |
| 103-039 | ANTIFREEZE TO -34F, OAT (NITRITE AND SILICATE FREE) EXTENDED LIFE COOLANT | | | STD |
| 171-007 | GATES BLUE STRIPE COOLANT HOSES OR EQUIVALENT | | | STD |
| 172-001 | CONSTANT TENSION HOSE CLAMPS FOR COOLANT HOSES | | | STD |
| 270-016 | RADIATOR DRAIN VALVE | | | STD |
| 360-013 | 1350 ADAPTER FLANGE FOR FRONT PTO PROVISION | 20 | | \$487.00 |
| 138-011 | PHILLIPS-TEMRO 1000 WATT/115 VOLT BLOCK HEATER | 4 | | \$92.00 |
| 140-053 | BLACK PLASTIC ENGINE HEATER RECEPTACLE MOUNTED UNDER LH DOOR | | | N/C |
| 132-004 | ELECTRIC GRID AIR INTAKE WARMER | | | STD |
| 155-058 | DELCO 12V 38MT HD STARTER WITH INTEGRATED MAGNETIC SWITCH | | | STD |

Transmission

| | | | | |
|---------|--|--|--|-----------|
| 342-584 | ALLISON 3500 RDS AUTOMATIC TRANSMISSION WITH PTO PROVISION | | | (\$75.00) |
|---------|--|--|--|-----------|

Transmission Equipment

| | | | | |
|---------|---|--|--|-----|
| 343-339 | ALLISON VOCATIONAL PACKAGE 223 - AVAILABLE ON 3000/4000 PRODUCT FAMILIES WITH VOCATIONAL MODELS RDS, HS, MH AND TRV | | | STD |
| 84B-012 | ALLISON VOCATIONAL RATING FOR ON/OFF HIGHWAY APPLICATIONS AVAILABLE WITH ALL PRODUCT FAMILIES | | | N/C |
| 84C-023 | PRIMARY MODE GEARS, LOWEST GEAR 1, START GEAR 1, HIGHEST GEAR 6, AVAILABLE FOR 3000/4000 PRODUCT FAMILIES ONLY | | | STD |
| 84D-023 | SECONDARY MODE GEARS, LOWEST GEAR 1, START GEAR 1, HIGHEST GEAR 6, AVAILABLE FOR 3000/4000 PRODUCT FAMILIES ONLY | | | STD |



7e

Prepared for:
 Ryan Reed
 MISSOURI DOT
 830 MoDOT Drive
 605CO23002393
 JEFFERSON CITY, MO 65109
 Phone: (573) 751-3685

Prepared by:
 Matt Pace
 TRUCK CENTERS, INC.
 2280 FORMOSA RD.
 TROY, IL 62294
 Phone: 618-667-3454

| Data Code | Description | Weight Front | Weight Rear | Retail Price |
|-----------|---|--------------|-------------|--------------|
| 84E-017 | S5 PERFORMANCE LIMITING PRIMARY SHIFT SCHEDULE, AVAILABLE FOR 3000/4000 PRODUCT FAMILIES ONLY | | | N/C |
| 84F-016 | S5 PERFORMANCE LIMITING SECONDARY SHIFT SCHEDULE, AVAILABLE FOR 3000/4000 PRODUCT FAMILIES ONLY | | | N/C |
| 84G-013 | 2100 RPM PRIMARY MODE SHIFT SPEED | | | N/C |
| 84H-014 | 2200 RPM SECONDARY MODE SHIFT SPEED | | | N/C |
| 84K-002 | 2ND GEAR ENGINE BRAKE ALTERNATE PRESELECT WITH MODERATE DOWNSHIFT STRATEGY | | | STD |
| 84N-200 | FUEL SENSE 2.0 DISABLED - PERFORMANCE - TABLE BASED | | | STD |
| 84U-000 | DRIVER SWITCH INPUT - DEFAULT - NO SWITCHES | | | STD |
| 353-076 | QUICKFIT BODY LIGHTING CONNECTOR AT END OF FRAME, WITH BLUNTCUTS | | | \$200.00 |
| 34C-011 | ELECTRONIC TRANSMISSION WIRING TO CUSTOMER INTERFACE CONNECTOR | | | \$125.00 |
| 362-824 | (2) CUSTOMER INSTALLED CHELSEA 280 SERIES PTO'S | | | N/C |
| 363-011 | PTO MOUNTING, LH AND RH SIDES OF MAIN TRANSMISSION | | | N/C |
| 341-018 | MAGNETIC PLUGS, ENGINE DRAIN, TRANSMISSION DRAIN, AXLE(S) FILL AND DRAIN | | | STD |
| 345-003 | PUSH BUTTON ELECTRONIC SHIFT CONTROL, DASH MOUNTED | | | \$254.00 |
| 97G-004 | TRANSMISSION PROGNOSTICS - ENABLED 2013 | | | STD |
| 370-015 | WATER TO OIL TRANSMISSION COOLER, IN RADIATOR END TANK | | | STD |
| 346-003 | TRANSMISSION OIL CHECK AND FILL WITH ELECTRONIC OIL LEVEL CHECK | | | STD |
| 35T-001 | SYNTHETIC TRANSMISSION FLUID (TES-295 COMPLIANT) | | | STD |

Front Axle and Equipment

| | | | | |
|---------|---|----|--|----------|
| 400-1A8 | DETROIT DA-F-14.7-3 14,700# FF1 71.5 KPI/3.74 DROP SINGLE FRONT AXLE | 10 | | \$980.00 |
| 402-049 | MERITOR 16.5X5 Q+ CAST SPIDER CAM FRONT BRAKES, DOUBLE ANCHOR, FABRICATED SHOES | | | N/C |
| 403-002 | NON-ASBESTOS FRONT BRAKE LINING | | | STD |
| 419-023 | CONMET CAST IRON FRONT BRAKE DRUMS | | | \$8.00 |
| 427-001 | FRONT BRAKE DUST SHIELDS | 5 | | \$102.00 |



Prepared for:
 Ryan Reed
 MISSOURI DOT
 830 MoDOT Drive
 605CO23002393
 JEFFERSON CITY, MO 65109
 Phone: (573) 751-3685

Prepared by:
 Matt Pace
 TRUCK CENTERS, INC.
 2280 FORMOSA RD.
 TROY, IL 62294
 Phone: 618-667-3454

| Data Code | Description | Weight Front | Weight Rear | Retail Price |
|--------------------------------|---|--------------|-------------|--------------|
| 409-006 | FRONT OIL SEALS | | | STD |
| 408-001 | VENTED FRONT HUB CAPS WITH WINDOW, CENTER AND SIDE PLUGS - OIL | | | STD |
| 416-022 | STANDARD SPINDLE NUTS FOR ALL AXLES | | | STD |
| 405-002 | MERITOR AUTOMATIC FRONT SLACK ADJUSTERS | | | STD |
| 406-001 | STANDARD KING PIN BUSHINGS | | | STD |
| 536-012 | TRW TAS-85 POWER STEERING | 40 | | N/C |
| 539-003 | POWER STEERING PUMP | | | STD |
| 534-015 | 2 QUART SEE THROUGH POWER STEERING RESERVOIR | | | STD |
| 40T-002 | CURRENT AVAILABLE SYNTHETIC 75W-90 FRONT AXLE LUBE | | | \$17.00 |
| Front Suspension | | | | |
| 620-010 | 14,600# TAPERLEAF FRONT SUSPENSION | 170 | | \$484.00 |
| 619-005 | MAINTENANCE FREE RUBBER BUSHINGS - FRONT SUSPENSION | | | STD |
| 410-001 | FRONT SHOCK ABSORBERS | | | STD |
| Rear Axle and Equipment | | | | |
| 420-051 | RS-23-160 23,000# R-SERIES SINGLE REAR AXLE | | 180 | \$872.00 |
| 421-563 | 5.63 REAR AXLE RATIO | | | N/C |
| 424-001 | IRON REAR AXLE CARRIER WITH STANDARD AXLE HOUSING | | | STD |
| 386-073 | MXL 17T MERITOR EXTENDED LUBE MAIN DRIVELINE WITH HALF ROUND YOKES | | | STD |
| 452-001 | DRIVER CONTROLLED TRACTION DIFFERENTIAL - SINGLE REAR AXLE | | 20 | \$734.00 |
| 878-018 | (1) DRIVER CONTROLLED DIFFERENTIAL LOCK REAR VALVE FOR SINGLE DRIVE AXLE | | | N/C |
| 87B-015 | INDICATOR LIGHT FOR EACH DIFFERENTIAL LOCKOUT SWITCH, ENGAGE <5 MPH, DISENGAGE >25 MPH | | | N/C |
| 423-033 | MERITOR 16.5X7 Q+ CAST SPIDER HEAVY DUTY CAM REAR BRAKES, DOUBLE ANCHOR, FABRICATED SHOES | | | \$140.00 |
| 433-002 | NON-ASBESTOS REAR BRAKE LINING | | | STD |
| 434-011 | BRAKE CAMS AND CHAMBERS ON FORWARD SIDE OF DRIVE AXLE(S) | | | N/C |
| 451-023 | CONMET CAST IRON REAR BRAKE DRUMS | | | \$43.00 |
| 425-002 | REAR BRAKE DUST SHIELDS | | 5 | \$65.00 |
| 440-006 | REAR OIL SEALS | | | STD |



Prepared for:
 Ryan Reed
 MISSOURI DOT
 830 MoDOT Drive
 605CO23002393
 JEFFERSON CITY, MO 65109
 Phone: (573) 751-3685

Prepared by:
 Matt Pace
 TRUCK CENTERS, INC.
 2280 FORMOSA RD.
 TROY, IL 62294
 Phone: 618-667-3454

| Data Code | Description | Weight Front | Weight Rear | Retail Price |
|-------------------------------|---|--------------|-------------|--------------|
| 426-100 | WABCO TRISTOP D LONGSTROKE 1-DRIVE AXLE SPRING PARKING CHAMBERS | | | STD |
| 428-002 | MERITOR AUTOMATIC REAR SLACK ADJUSTERS | | | STD |
| 41T-002 | CURRENT AVAILABLE SYNTHETIC 75W-90 REAR AXLE LUBE | | | STD |
| 42T-001 | STANDARD REAR AXLE BREATHER(S) | | | STD |
| Rear Suspension | | | | |
| 622-003 | 23,000# FLAT LEAF SPRING REAR SUSPENSION WITH HELPER AND RADIUS ROD | | 50 | \$347.00 |
| 621-001 | SPRING SUSPENSION - NO AXLE SPACERS | | | STD |
| 431-001 | STANDARD AXLE SEATS IN AXLE CLAMP GROUP | | | STD |
| 623-005 | FORE/AFT CONTROL RODS | | | STD |
| Pusher / Tag Equipment | | | | |
| 429-998 | NO PUSHER/TAG BRAKE DUST SHIELDS | | | STD |
| Brake System | | | | |
| 490-1AU | WABCO 4S/4M ABS WITH TRACTION CONTROL WITH ATC SHUT OFF SWITCH | | | \$232.00 |
| 871-001 | REINFORCED NYLON, FABRIC BRAID AND WIRE BRAID CHASSIS AIR LINES | | | STD |
| 904-001 | FIBER BRAID PARKING BRAKE HOSE | | | STD |
| 412-001 | STANDARD BRAKE SYSTEM VALVES | | | STD |
| 46D-002 | STANDARD AIR SYSTEM PRESSURE PROTECTION SYSTEM | | | STD |
| 413-002 | STD U.S. FRONT BRAKE VALVE | | | STD |
| 432-003 | RELAY VALVE WITH 5-8 PSI CRACK PRESSURE, NO REAR PROPORTIONING VALVE | | | STD |
| 480-086 | BW AD-9SI BRAKE LINE AIR DRYER WITH HEATER | | | \$2.00 |
| 479-015 | AIR DRYER FRAME MOUNTED | | | STD |
| 460-001 | STEEL AIR BRAKE RESERVOIRS | | | STD |
| 477-036 | PULL CABLES ON ALL AIR RESERVOIRS WITH KEY RING TYPE ATTACHMENT | | | \$3.00 |
| Trailer Connections | | | | |
| 481-998 | NO TRAILER AIR HOSE | | | STD |
| 476-998 | NO AIR HOSE HANGER | | | STD |
| 914-025 | AIR CONNECTIONS TO END OF FRAME WITH GLAD HANDS FOR TRUCK AND DUST COVERS | | | \$9.00 |



Prepared for:
 Ryan Reed
 MISSOURI DOT
 830 MoDOT Drive
 605CO23002393
 JEFFERSON CITY, MO 65109
 Phone: (573) 751-3685

Prepared by:
 Matt Pace
 TRUCK CENTERS, INC.
 2280 FORMOSA RD.
 TROY, IL 62294
 Phone: 618-667-3454

| Data Code | Description | Weight Front | Weight Rear | Retail Price |
|------------------------------|---|--------------|-------------|--------------|
| 919-059 | (1) ADDITIONAL SWITCH FOR ELEC/AIR SOLENOID W/STATE RETENTION PLUMBED TO END OF FRAME | | | \$144.00 |
| 296-026 | PRIMARY CONNECTOR/RECEPTACLE WIRED FOR SEPARATE STOP/TURN, CENTER PIN POWERED THROUGH IGNITION WITH STOP SIGNAL PREWIRE PACKAGE | | | \$8.00 |
| 303-025 | SAE J560 7-WAY PRIMARY TRAILER CABLE RECEPTACLE MOUNTED END OF FRAME | | | N/C |
| 310-998 | NO TRAILER ELECTRICAL CABLE | | | STD |
| Wheelbase & Frame | | | | |
| 545-382 | 3825MM (151 INCH) WHEELBASE | | | N/C |
| 546-102 | 7/16X3-9/16X11-1/8 INCH STEEL FRAME (11.11MMX282.6MM/0.437X11.13 INCH) 120KSI | 110 | 170 | \$588.00 |
| 548-803 | TEM TO EVALUATE AND INSTALL FRAME RAIL REINFORCEMENT AS NEEDED FOR FRONT FRAME MOUNTED EQUIPMENT | | | N/C |
| 552-032 | 1650MM (65 INCH) REAR FRAME OVERHANG | | | N/C |
| 55W-006 | FRAME OVERHANG RANGE: 61 INCH TO 70 INCH | | | N/C |
| 549-002 | 24 INCH INTEGRAL FRONT FRAME EXTENSION | 140 | -20 | \$4.00 |
| AC8-99D | CALC'D BACK OF CAB TO REAR SUSP C/L (CA) : 85.04 in | | | |
| AE8-99D | CALCULATED EFFECTIVE BACK OF CAB TO REAR SUSPENSION C/L (CA) : 82.04 in | | | |
| AE4-99D | CALC'D FRAME LENGTH - OVERALL : 276.99 in | | | |
| FSS-0LH | CALCULATED FRAME SPACE LH SIDE : 48.36 in | | | N/C |
| FSS-0RH | CALCULATED FRAME SPACE RH SIDE : 52.42 in | | | N/C |
| 553-001 | SQUARE END OF FRAME | | | STD |
| 550-001 | FRONT CLOSING CROSSMEMBER | | | STD |
| 559-001 | STANDARD WEIGHT ENGINE CROSSMEMBER | | | STD |
| 562-001 | STANDARD MIDSHIP #1 CROSSMEMBER(S) | | | STD |
| 572-001 | STANDARD REARMOST CROSSMEMBER | | | STD |
| 565-001 | STANDARD SUSPENSION CROSSMEMBER | | | STD |
| Chassis Equipment | | | | |
| 556-997 | OMIT FRONT BUMPER, CUSTOMER INSTALLED SPECIAL BUMPER, DOES NOT COMPLY WITH FMCSR 393.203 | -110 | | (\$488.00) |
| 558-001 | FRONT TOW HOOKS - FRAME MOUNTED | 15 | | \$80.00 |
| 585-998 | NO MUDFLAP BRACKETS | | | STD |
| 590-998 | NO REAR MUDFLAPS | | | STD |



7e

Prepared for:
 Ryan Reed
 MISSOURI DOT
 830 MoDOT Drive
 605CO23002393
 JEFFERSON CITY, MO 65109
 Phone: (573) 751-3685

Prepared by:
 Matt Pace
 TRUCK CENTERS, INC.
 2280 FORMOSA RD.
 TROY, IL 62294
 Phone: 618-667-3454

| Data Code | Description | Weight Front | Weight Rear | Retail Price |
|--------------------|--|--------------|-------------|--------------|
| 551-007 | GRADE 8 THREADED HEX HEADED FRAME FASTENERS | | | STD |
| 44Z-002 | EXTERIOR HARNESSSES WRAPPED IN ABRASION TAPE | | | STD |
| 607-001 | CLEAR FRAME RAILS FROM BACK OF CAB TO FRONT REAR SUSPENSION BRACKET, BOTH RAILS OUTBOARD | | | \$218.00 |
| Fifth Wheel | | | | |
| 578-998 | NO FIFTH WHEEL | | | STD |
| Fuel Tanks | | | | |
| 204-215 | 50 GALLON/189 LITER SHORT RECTANGULAR ALUMINUM FUEL TANK - LH | -10 | | \$30.00 |
| 218-005 | RECTANGULAR FUEL TANK(S) | | | N/C |
| 215-005 | PLAIN ALUMINUM/PAINTED STEEL FUEL/HYDRAULIC TANK(S) WITH PAINTED BANDS | | | STD |
| 212-007 | FUEL TANK(S) FORWARD | | | STD |
| 664-001 | PLAIN STEP FINISH | | | STD |
| 205-001 | FUEL TANK CAP(S) | | | STD |
| 122-1J1 | DETROIT FUEL/WATER SEPARATOR WITH WATER IN FUEL SENSOR, HAND PRIMER AND 12 VOLT PREHEATER" | -5 | | \$51.00 |
| 216-020 | EQUIFLO INBOARD FUEL SYSTEM | | | STD |
| 202-016 | HIGH TEMPERATURE REINFORCED NYLON FUEL LINE | | | STD |
| Tires | | | | |
| 093-1RJ | MICHELIN X WORKS Z 315/80R22.5 20 PLY RADIAL FRONT TIRES | 100 | | \$474.00 |
| 094-17X | MICHELIN X MULTI D+ 11R22.5 16 PLY RADIAL REAR TIRES | | 60 | (\$40.00) |
| Hubs | | | | |
| 418-060 | CONMET PRESET PLUS PREMIUM IRON FRONT HUBS | | | STD |
| 450-060 | CONMET PRESET PLUS PREMIUM IRON REAR HUBS | | | STD |
| Wheels | | | | |
| 502-579 | MAXION WHEELS 10041 22.5X9.00 10-HUB PILOT 5.25 INSET 5-HAND STEEL DISC FRONT WHEELS | 66 | | \$204.00 |
| 505-545 | MAXION WHEELS 90260 22.5X8.25 10-HUB PILOT 2-HAND HD STEEL DISC REAR WHEELS | | 80 | (\$32.00) |
| 496-011 | FRONT WHEEL MOUNTING NUTS | | | STD |



7e

Prepared for:
 Ryan Reed
 MISSOURI DOT
 830 MoDOT Drive
 605CO23002393
 JEFFERSON CITY, MO 65109
 Phone: (573) 751-3685

Prepared by:
 Matt Pace
 TRUCK CENTERS, INC.
 2280 FORMOSA RD.
 TROY, IL 62294
 Phone: 618-667-3454

| Data Code | Description | Weight Front | Weight Rear | Retail Price |
|---------------------|---|--------------|-------------|--------------|
| 497-011 | REAR WHEEL MOUNTING NUTS | | | STD |
| 498-011 | NYLON WHEEL GUARDS FRONT AND REAR ALL INTERFACES | | | \$32.00 |
| Cab Exterior | | | | |
| 829-1A5 | 108 INCH BBC FLAT ROOF ALUMINUM CONVENTIONAL CAB | | | STD |
| 650-008 | AIR CAB MOUNTING | | | STD |
| 648-002 | NONREMOVABLE BUGSCREEN MOUNTED BEHIND GRILLE | | | STD |
| 667-037 | SHORT FENDER WITH MUDFLAP | | | \$141.00 |
| 754-017 | BOLT-ON MOLDED FLEXIBLE FENDER EXTENSIONS | 10 | | \$115.00 |
| 678-001 | LH AND RH GRAB HANDLES | | | STD |
| 645-002 | BRIGHT FINISH RADIATOR SHELL/HOOD BEZEL | | | \$253.00 |
| 646-042 | STATIONARY BLACK GRILLE WITH BRIGHT ACCENTS | | | \$88.00 |
| 65X-003 | CHROME HOOD MOUNTED AIR INTAKE GRILLE | | | \$15.00 |
| 644-004 | FIBERGLASS HOOD | | | STD |
| 690-007 | HOOD LINER INSULATION WITH SINGLE FIREWALL INSULATION | | | N/C |
| 727-1AH | SINGLE 14 INCH ROUND POLISHED AIR HORN ROOF MOUNTED | | | STD |
| 726-001 | SINGLE ELECTRIC HORN | | | STD |
| 728-001 | SINGLE HORN SHIELD | | | STD |
| 312-067 | HALOGEN COMPOSITE HEADLAMPS WITH BRIGHT BEZELS | | | N/C |
| 302-047 | LED AERODYNAMIC MARKER LIGHTS | | | STD |
| 314-824 | WIRING AND SWITCH FOR CUSTOMER FURNISHED SNOW PLOW LAMPS WITH DUAL CONNECTIONS AT BUMPER | | | \$162.00 |
| 311-021 | HEADLIGHTS ON WITH WIPERS, NO DAYTIME RUNNING LIGHTS | | | \$21.00 |
| 294-001 | INTEGRAL STOP/TAIL/BACKUP LIGHTS | | | STD |
| 300-015 | STANDARD FRONT TURN SIGNAL LAMPS | | | STD |
| 318-032 | SWITCH, INDICATOR LIGHT AND APPROXIMATELY 10 FEET OF WIRE ON CHASSIS RH BACK OF CAB FOR CUSTOMER FURNISHED UTILITY LIGHT(S) | | | \$47.00 |
| 744-1BC | DUAL WEST COAST BRIGHT FINISH HEATED MIRRORS WITH LH AND RH REMOTE | | | \$133.00 |
| 797-001 | DOOR MOUNTED MIRRORS | | | STD |
| 796-001 | 102 INCH EQUIPMENT WIDTH | | | STD |



Prepared for:
 Ryan Reed
 MISSOURI DOT
 830 MoDOT Drive
 605CO23002393
 JEFFERSON CITY, MO 65109
 Phone: (573) 751-3685

Prepared by:
 Matt Pace
 TRUCK CENTERS, INC.
 2280 FORMOSA RD.
 TROY, IL 62294
 Phone: 618-667-3454

| Data Code | Description | Weight Front | Weight Rear | Retail Price |
|-----------|--|--------------|-------------|--------------|
| 743-204 | LH AND RH 8 INCH BRIGHT FINISH CONVEX MIRRORS MOUNTED UNDER PRIMARY MIRRORS | | | N/C |
| 729-001 | STANDARD SIDE/REAR REFLECTORS | | | STD |
| 275-061 | PARK BRAKE REMINDER WARNING SYSTEM | | | \$3.00 |
| 768-043 | 63X14 INCH TINTED REAR WINDOW | | | STD |
| 661-003 | TINTED DOOR GLASS LH AND RH WITH TINTED NON-OPERATING WING WINDOWS | | | (\$117.00) |
| 654-011 | RH AND LH ELECTRIC POWERED WINDOWS | | | STD |
| 663-029 | 1-PIECE BONDED HEATED WIPER PARK SOLAR GREEN GLASS WINDSHIELD | | | \$423.00 |
| 659-006 | 8 LITER (2 GAL) WINDSHIELD WASHER RESERVOIR, CAB MOUNTED, WITH FLUID LEVEL INDICATOR | | | \$15.00 |

Cab Interior

| | | | | |
|---------|--|----|--|---------|
| 055-019 | RUGGED TRIM PACKAGE | | | STD |
| 707-107 | GRAY & CARBON VINYL INTERIOR "RUGGED" | | | STD |
| 70K-020 | CARBON WITH PREMIUM GUNMETAL ACCENT (RUGGED) | | | STD |
| 706-013 | MOLDED PLASTIC DOOR PANEL | | | STD |
| 708-013 | MOLDED PLASTIC DOOR PANEL | | | STD |
| 772-006 | BLACK MATS WITH SINGLE INSULATION | | | STD |
| 785-026 | (1)DASH MOUNTED 12V POWER OUTLET, (1)DASH MOUNTED DUAL USB-C OUTLET | | | \$42.00 |
| 691-001 | FORWARD ROOF MOUNTED CONSOLE | | | STD |
| 696-012 | CENTER STORAGE CONSOLE MOUNTED ON BACKWALL | 20 | | \$26.00 |
| 693-019 | LH AND RH DOOR STORAGE POCKETS INTEGRATED INTO MOLDED DOOR PANELS | | | STD |
| 738-021 | DIGITAL ALARM CLOCK IN DRIVER DISPLAY | | | STD |
| 742-007 | (2) CUP HOLDERS LH AND RH DASH | | | STD |
| 680-029 | M2/SD DASH | | | STD |
| 700-002 | HEATER, DEFROSTER AND AIR CONDITIONER | | | STD |
| 701-008 | STANDARD HVAC DUCTING WITH SNOW SHIELD FOR FRESH AIR INTAKE | | | \$31.00 |
| 703-005 | MAIN HVAC CONTROLS WITH RECIRCULATION SWITCH | | | STD |
| 170-045 | STANDARD HEATER PLUMBING WITH BALL SHUTOFF VALVES AT SUPPLY LINES ONLY | | | \$16.00 |
| 130-041 | VALEO HEAVY DUTY A/C REFRIGERANT COMPRESSOR | | | STD |
| 702-002 | BINARY CONTROL, R-134A | | | STD |



Prepared for:
 Ryan Reed
 MISSOURI DOT
 830 MoDOT Drive
 605CO23002393
 JEFFERSON CITY, MO 65109
 Phone: (573) 751-3685

Prepared by:
 Matt Pace
 TRUCK CENTERS, INC.
 2280 FORMOSA RD.
 TROY, IL 62294
 Phone: 618-667-3454

| Data Code | Description | Weight Front | Weight Rear | Retail Price |
|-----------|---|--------------|-------------|--------------|
| 739-034 | PREMIUM INSULATION | | | \$145.00 |
| 285-013 | SOLID-STATE CIRCUIT PROTECTION AND FUSES | | | STD |
| 280-007 | 12V NEGATIVE GROUND ELECTRICAL SYSTEM | | | STD |
| 324-1B3 | STANDARD LED CAB LIGHTING | | | STD |
| 787-998 | NO SECURITY DEVICE | | | (\$300.00) |
| 657-001 | DOOR LOCKS AND IGNITION SWITCH KEYED THE SAME | | | STD |
| 78G-004 | KEY QUANTITY OF 4 | | | \$18.00 |
| 655-005 | LH AND RH ELECTRIC DOOR LOCKS | | | STD |
| 756-339 | PREMIUM ISRINGHAUSEN HIGH BACK AIR SUSPENSION DRIVERS SEAT WITH 2 AIR LUMBAR, INTEGRATED CUSHION EXTENSION, TILT AND ADJUSTABLE SHOCK | 70 | | \$414.00 |
| 760-339 | PREMIUM ISRINGHAUSEN HIGH BACK AIR SUSPENSION PASSENGER SEAT WITH 2 AIR LUMBAR, INTEGRATED CUSHION EXTENSION, TILT AND ADJUSTABLE SHOCK | 60 | 20 | \$451.00 |
| 759-007 | DUAL DRIVER SEAT ARMRESTS, NO PASSENGER SEAT ARMRESTS | 4 | | \$69.00 |
| 711-004 | LH AND RH INTEGRAL DOOR PANEL ARMRESTS | | | STD |
| 758-1AK | BLACK VINYL DRIVER SEAT COVER | | | (\$78.00) |
| 761-1AK | BLACK VINYL PASSENGER SEAT COVER | | | (\$74.00) |
| 763-101 | BLACK SEAT BELTS | | | STD |
| 532-002 | ADJUSTABLE TILT AND TELESCOPING STEERING COLUMN | | | STD |
| 540-044 | 4-SPOKE 18 INCH (450MM) BLACK STEERING WHEEL WITH SWITCHES | | | (\$124.00) |
| 765-002 | DRIVER AND PASSENGER INTERIOR SUN VISORS | | | STD |

Instruments & Controls

| | | | | |
|-----------|--|--|--|----------|
| * 4CH-006 | 6 EXTRA PROGRAMMABLE SWITCHES/INDICATORS | | | \$135.00 |
| | \$C2A0071ZZ,C4U0215ZZ,C2B0000ZZ,C1B0000ZZ ,C2C0046ZZ,C2D0060ZZ | | | |
| 106-002 | ELECTRONIC ACCELERATOR CONTROL | | | STD |
| 732-998 | NO INSTRUMENT PANEL-DRIVER | | | STD |
| 734-022 | FULLY CONFIGURABLE CENTER INSTRUMENT PANELS | | | STD |
| 87L-005 | ENGINE REMOTE INTERFACE WITHOUT INTERLOCKS | | | N/C |
| 870-002 | BRIGHT ARGENT FINISH GAUGE BEZELS | | | STD |
| 486-001 | LOW AIR PRESSURE INDICATOR LIGHT AND AUDIBLE ALARM | | | STD |



Prepared for:
 Ryan Reed
 MISSOURI DOT
 830 MoDOT Drive
 605CO23002393
 JEFFERSON CITY, MO 65109
 Phone: (573) 751-3685

Prepared by:
 Matt Pace
 TRUCK CENTERS, INC.
 2280 FORMOSA RD.
 TROY, IL 62294
 Phone: 618-667-3454

| Data Code | Description | Weight Front | Weight Rear | Retail Price |
|-----------|---|--------------|-------------|--------------|
| 840-001 | DUAL NEEDLE PRIMARY AND SECONDARY AIR PRESSURE GAUGE | | | STD |
| 198-025 | INTAKE MOUNTED AIR RESTRICTION INDICATOR WITHOUT GRADUATIONS | | | STD |
| 721-001 | 97 DB BACKUP ALARM | | 3 | \$47.00 |
| 149-015 | ELECTRONIC CRUISE CONTROL WITH CONTROLS ON STEERING WHEEL SPOKES | | | STD |
| 156-007 | KEY OPERATED IGNITION SWITCH AND INTEGRAL START POSITION; 4 POSITION OFF/RUN/START/ACCESSORY | | | STD |
| 811-044 | PREMIUM INSTRUMENT CLUSTER WITH 5.0 INCH TFT COLOR DISPLAY | | | STD |
| 81B-003 | DIGITAL PANEL LAMP DIMMER SWITCH IN DRIVER DISPLAY | | | STD |
| 160-038 | HEAVY DUTY ONBOARD DIAGNOSTICS INTERFACE CONNECTOR LOCATED BELOW LH DASH | | | STD |
| 844-001 | 2 INCH ELECTRIC FUEL GAUGE | | | STD |
| 148-072 | ENGINE REMOTE INTERFACE WITH ONE OR MORE SET SPEEDS | | | \$134.00 |
| 48H-004 | QUICKFIT POWERTRAIN INTERFACE CONNECTOR UNDER CAB WITH BLUNTCUTS | | | \$96.00 |
| 48C-004 | QUICKFIT PROGRAMMABLE INTERFACE CONNECTOR(S) UNDER CAB WITH BLUNTCUTS | | | \$46.00 |
| 163-014 | ENGINE REMOTE INTERFACE CONNECTOR AT POWERTRAIN INTERFACE CONNECTOR | | | N/C |
| 856-001 | ELECTRICAL ENGINE COOLANT TEMPERATURE GAUGE | | | STD |
| 852-002 | ELECTRIC ENGINE OIL PRESSURE GAUGE | | | STD |
| 864-001 | 2 INCH TRANSMISSION OIL TEMPERATURE GAUGE | | | \$30.00 |
| 867-004 | ELECTRONIC OUTSIDE TEMPERATURE SENSOR DISPLAY IN DRIVER MESSAGE CENTER | | | STD |
| 830-006 | ENGINE AND TRIP HOUR METERS INTEGRAL WITHIN DRIVER DISPLAY AND HOBBS PTO OPERATION HOUR METER | 2 | | \$52.00 |
| 372-123 | PTO CONTROLS FOR ENHANCED VEHICLE ELECTRIC/ELECTRONIC ARCHITECTURE | | | \$40.00 |
| 736-998 | NO OBSTACLE DETECTION SYSTEM | | | (\$4,324.00) |
| 72J-998 | NO DR ASSIST SYSTEM | | | (\$32.00) |
| 49B-004 | ELECTRONIC STABILITY CONTROL | | | N/C |
| 73B-998 | NO LANE DEPARTURE WARNING SYSTEM | | | (\$1,080.00) |
| 679-998 | NO OVERHEAD INSTRUMENT PANEL | | | STD |



Prepared for:
 Ryan Reed
 MISSOURI DOT
 830 MoDOT Drive
 605CO23002393
 JEFFERSON CITY, MO 65109
 Phone: (573) 751-3685

Prepared by:
 Matt Pace
 TRUCK CENTERS, INC.
 2280 FORMOSA RD.
 TROY, IL 62294
 Phone: 618-667-3454

| Data Code | Description | Weight Front | Weight Rear | Retail Price |
|-----------|--|--------------|-------------|--------------|
| 35M-011 | QUICKFIT PROGRAMMABLE INTERFACE MODULE + (4) 20 AMP FUSED RELAYS | 10 | | \$173.00 |
| 786-113 | GENERIC TELEMATICS PREWIRE (CONSTANT BATTERY POWER/IGNITION/GROUND/J1939); RP1226 TYPE CONNECTOR AT PASSENGER SIDE OF DASH END | | | \$34.00 |
| 746-136 | AM/FM/WB WORLD TUNER RADIO WITH AUXILIARY INPUT, J1939 | 10 | | N/C |
| 747-001 | DASH MOUNTED RADIO | | | STD |
| 750-002 | (2) RADIO SPEAKERS IN CAB | | | STD |
| 753-998 | NO AM/FM RADIO ANTENNA | | | (\$23.00) |
| 748-006 | POWER AND GROUND WIRING PROVISION OVERHEAD | | | N/C |
| 749-001 | ROOF/OVERHEAD CONSOLE CB RADIO PROVISION | | | N/C |
| 752-017 | MULTI-BAND AM/FM/WB/CB LH MIRROR MOUNTED ANTENNA SYSTEM | | | \$293.00 |
| 74D-006 | STANDARD RADIO WIRING WITH STEERING WHEEL CONTROLS | | | STD |
| 810-027 | ELECTRONIC MPH SPEEDOMETER WITH SECONDARY KPH SCALE, WITHOUT ODOMETER | | | STD |
| 817-001 | STANDARD VEHICLE SPEED SENSOR | | | STD |
| 812-001 | ELECTRONIC 3000 RPM TACHOMETER | | | STD |
| 813-1C8 | DETROIT CONNECT PLATFORM HARDWARE | | | STD |
| 8D1-303 | 3 YEARS DAIMLER CONNECTIVITY BASE PACKAGE (FEATURES VARY BY MODEL) POWERED BY DETROIT CONNECT | | | STD |
| 6TS-008 | (2) TMC RP1226 ACCESSORY CONNECTORS: (1) LOCATED BEHIND PASSENGER SIDE REMOVABLE DASH PANEL (1) CENTER OF OVERHEAD CONSOLE | | | \$30.00 |
| 162-002 | IGNITION SWITCH CONTROLLED ENGINE STOP | | | STD |
| 81Y-005 | PRE-TRIP INSPECTION FEATURE FOR EXTERIOR LAMPS ONLY | | | \$12.00 |
| 264-030 | (1) OVERHEAD MOUNTED LANYARD CONTROL FOR DRIVER AIR HORN | | | STD |
| 482-001 | BW TRACTOR PROTECTION VALVE | | | N/C |
| 883-001 | TRAILER HAND CONTROL BRAKE VALVE | | | N/C |
| 842-006 | DIGITAL TURBO AIR PRESSURE IN DRIVER DISPLAY | | | N/C |
| 836-015 | DIGITAL VOLTAGE DISPLAY INTEGRAL WITH DRIVER DISPLAY | | | STD |



7e

Prepared for:
 Ryan Reed
 MISSOURI DOT
 830 MoDOT Drive
 605CO23002393
 JEFFERSON CITY, MO 65109
 Phone: (573) 751-3685

Prepared by:
 Matt Pace
 TRUCK CENTERS, INC.
 2280 FORMOSA RD.
 TROY, IL 62294
 Phone: 618-667-3454

| Data Code | Description | Weight Front | Weight Rear | Retail Price |
|-----------|---|--------------|-------------|--------------|
| 660-025 | SINGLE ELECTRIC WINDSHIELD WIPER MOTOR WITH DELAY PROGRAMMED TO SLOWEST SPEED WITH PARK BRAKE SET | | | \$19.00 |
| 304-030 | ROTARY HEADLAMP SWITCH, MARKER LIGHTS/HEADLIGHTS SWITCH WITH PULL OUT FOR OPTIONAL FOG/ROAD LAMPS | | | N/C |
| 882-004 | TWO VALVE PARKING BRAKE SYSTEM WITH WARNING INDICATOR | | | N/C |
| 299-020 | SELF CANCELING TURN SIGNAL SWITCH WITH DIMMER, HEADLAMP FLASH, WASH/WIPE/INTERMITTENT | | | STD |
| 298-046 | INTEGRAL ELECTRONIC TURN SIGNAL FLASHER WITH 40 AMP (20 AMP PER SIDE) TRAILER LAMP CAPACITY | | | STD |
| 87G-008 | OPTIONAL AIR SWITCH 1 WITH IGN ON & VEHICLE AT STANDSTILL | | | N/C |
| 87T-998 | NO WRG/SW-OPTL #2,CHAS,AIR | | | STD |

Design

| | | | | |
|---------|------------------------|--|--|-----|
| 065-000 | PAINT: ONE SOLID COLOR | | | STD |
|---------|------------------------|--|--|-----|

Color

| | | | | |
|---------|--|--|--|-----|
| 980-5F6 | CAB COLOR A: L0006EY WHITE ELITE EY | | | STD |
| 986-020 | BLACK, HIGH SOLIDS POLYURETHANE CHASSIS PAINT | | | STD |
| 962-972 | POWDER WHITE (N0006EA) FRONT WHEELS/RIMS (PKWHT21, TKWHT21, W, TW) | | | STD |
| 966-972 | POWDER WHITE (N0006EA) REAR WHEELS/RIMS (PKWHT21, TKWHT21, W, TW) | | | STD |
| 963-003 | STANDARD E COAT/UNDERCOATING | | | STD |

Certification / Compliance

| | | | | |
|---------|---|--|--|-----|
| 996-001 | U.S. FMVSS CERTIFICATION, EXCEPT SALES CABS AND GLIDER KITS | | | STD |
|---------|---|--|--|-----|

Secondary Factory Options

| | | | | |
|---------|--|--|--|-----|
| 998-001 | CORPORATE PDI CENTER IN-SERVICE ONLY | | | N/C |
| 999-062 | DEALER/CUSTOMER ADVISED AND ACCEPTS BUMPER SHOULD BE REMOVED PRIOR TO RECOVERING/TOWING THE VEHICLE PER FRACAS:11687 | | | N/C |

Sales Programs

NO SALES PROGRAMS HAVE BEEN SELECTED

TOTAL VEHICLE SUMMARY



7e

Prepared for:
 Ryan Reed
 MISSOURI DOT
 830 MoDOT Drive
 605CO23002393
 JEFFERSON CITY, MO 65109
 Phone: (573) 751-3685

Prepared by:
 Matt Pace
 TRUCK CENTERS, INC.
 2280 FORMOSA RD.
 TROY, IL 62294
 Phone: 618-667-3454

Adjusted List Price

Adjusted List Price ** \$142,015.00

Weight Summary

| | Weight Front | Weight Rear | Total Weight |
|-----------------------------|-----------------|----------------|-----------------|
| Factory Weight ⁺ | 7607 lbs | 4341 lbs | 11948 lbs |
| Total Weight ⁺ | 7607 lbs | 4341 lbs | 11948 lbs |

ITEMS NOT INCLUDED IN ADJUSTED LIST PRICE

Other Factory Charges

| | | |
|---------|---|------------|
| PMV-024 | GHG24 SURCHARGE - CUMMINS | \$555.00 |
| RD1-303 | 3 YRS DAIMLER CONNECTIVITY BASE PKG (VARY BY MODEL) POWERED BY DETRIOT CONNECT | STD |
| RAC-42N | M2/SD PLUS ESCALATOR | \$750.00 |
| RAG-020 | CUMMINS TARIFF CHARGE - \$205 | \$205.00 |
| RAU-025 | MY25 ESCALATOR | \$1,500.00 |
| RFY-022 | FRONT TIRE SURCHARGE | \$130.00 |
| RFU-022 | REAR TIRE SURCHARGE | \$260.00 |
| P73-2FT | STANDARD DESTINATION CHARGE | \$3,375.00 |

Extended Warranty

| | | |
|---------|---|----------|
| WAG-074 | TOWING: 1 YEAR/UNLIMITED MILES/KM EXTENDED TOWING COVERAGE \$750 CAP FEX APPLIES | \$230.00 |
| | Currency Exchange Rate | 1.0000 |
| | Total Extended Warranty (Local Currency) | \$230.00 |



Prepared for:
Ryan Reed
MISSOURI DOT
830 MoDOT Drive
605CO23002393
JEFFERSON CITY, MO 65109
Phone: (573) 751-3685

Prepared by:
Matt Pace
TRUCK CENTERS, INC.
2280 FORMOSA RD.
TROY, IL 62294
Phone: 618-667-3454

(+) Weights shown are estimates only.

If weight is critical, contact Customer Application Engineering.

(**) Prices shown do not include taxes, fees, etc... "Net Equipment Selling Price" is located on the Quotation Details Proposal Report.

(***) All cost increases for major components (Engines, Transmissions, Axles, Front and Rear Tires) and government mandated requirements, tariffs, and raw material surcharges will be passed through and added to factory invoices.



7e

Prepared for:
 Ryan Reed
 MISSOURI DOT
 830 MoDOT Drive
 605CO23002393
 JEFFERSON CITY, MO 65109
 Phone: (573) 751-3685

Prepared by:
 Matt Pace
 TRUCK CENTERS, INC.
 2280 FORMOSA RD.
 TROY, IL 62294
 Phone: 618-667-3454

D I M E N S I O N S

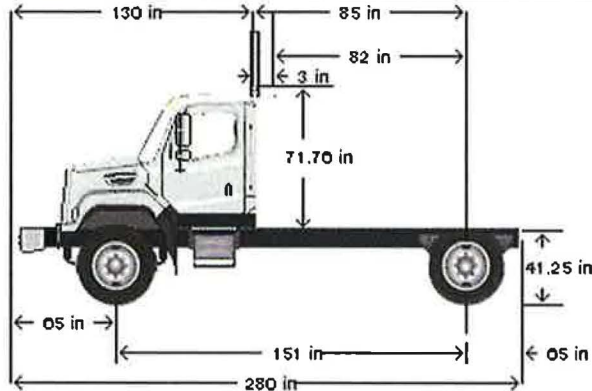

VEHICLE SPECIFICATIONS SUMMARY - DIMENSIONS

| | | |
|--------------------------------|-------|---|
| Wheelbase (545) | | 3825MM (151 INCH) WHEELBASE |
| Rear Frame Overhang (552) | | 1650MM (65 INCH) REAR FRAME OVERHANG |
| Fifth Wheel (578) | | NO FIFTH WHEEL |
| Mounting Location (577) | | NO FIFTH WHEEL LOCATION |
| Maximum Forward Position (in) | | 0 |
| Maximum Rearward Position (in) | | 0 |
| Amount of Slide Travel (in) | | 0 |
| Slide Increment (in) | | 0 |
| Desired Slide Position (in) | | 0.0 |
| Cab Size (829) | | 108 INCH BBC FLAT ROOF ALUMINUM CONVENTIONAL CAB |
| Sleeper (682) | | NO SLEEPER BOX/SLEEPER CAB |
| Exhaust System (016) | | RH OUTBOARD UNDER STEP MOUNTED HORIZONTAL AFTERTREATMENT SYSTEM ASSEMBLY WITH RH B-PILLAR MOUNTED VERTICAL TAILPIPE |

TABLE SUMMARY - DIMENSIONS



Prepared for:
 Ryan Reed
 MISSOURI DOT
 830 MoDOT Drive
 605CO23002393
 JEFFERSON CITY, MO 65109
 Phone: (573) 751-3685

Prepared by:
 Matt Pace
 TRUCK CENTERS, INC.
 2280 FORMOSA RD.
 TROY, IL 62294
 Phone: 618-667-3454

| Dimensions | Inches |
|--|--------|
| Bumper to Back of Cab (BBC) | 130.1 |
| Bumper to Centerline of Front Axle (BA) | 64.6 |
| Front Axle to Back of Cab (AC) | 65.6 |
| Min. Cab to Body Clearance (CB) | 3.0 |
| Back of Cab to Centerline of Rear Axle(s) (CA) | 85.0 |
| Effective Back of Cab to Centerline of Rear Axle(s) (Effective CA) | 82.0 |
| Back of Cab Protrusions (Exhaust/Intake) (CP) | 2.0 |
| Back of Cab Protrusions (Side Extenders/Trim Tab) (CP) | 0.0 |
| Back of Cab Protrusions (CNG Tank) | 0.0 |
| Back of Cab Clearance (CL) | 3.0 |
| Back of Cab to End of Frame | 150.0 |
| Cab Height (CH) | 71.8 |
| Wheelbase (WB) | 150.6 |
| Frame Overhang (OH) | 65.0 |
| Overall Frame Length | 277.0 |
| Overall Length (OAL) | 280.1 |
| Rear Axle Spacing | 0.0 |
| Unladen Frame Height at Centerline of Rear Axle | 41.2 |

Performance calculations are estimates only. If performance calculations are critical, please contact Customer Application Engineering.



70

BILL NO. _____ INTRODUCED BY _____

ORDINANCE NO. _____

AN ORDINANCE AUTHORIZING AND DIRECTING THE CITY OF WASHINGTON, MISSOURI TO ENTER INTO A SALES CONTRACT WITH WOODY'S MUNICIPAL SUPPLY CO. FOR THE PURCHASE OF A GALION 430U SMS TRUCK BED, SNOWPLOW & SALT SPREADER

Be It Ordained by the Council of the City of Washington, Missouri, as follows:

SECTION 1: The Mayor is hereby authorized to execute a Sales Contract with Woody's Municipal Supply Co. in an amount totaling Seventy One Thousand, Eight Hundred Sixty Eight Dollars, and Zero Cents (\$71,868.00) for the purchase of a Galion 430U SMS Truck Bed, Snowplow & Salt Spreader. A copy of said sales contract is attached hereto and marked as Exhibit A.

SECTION 2: All ordinances or parts of ordinances in conflict herewith are hereby repealed.

SECTION 3: This ordinance shall take effect and be in full force from and after it's passage and approval.

Passed: _____

ATTEST: _____

President of City Council

Approved: _____

ATTEST: _____

Mayor of Washington, Missouri

Exhibit A

SALES CONTRACT

This Sales Contract made and entered into this _____ day of _____, 2024, by and between Woody's Municipal Supply Co., PO BOX 432, Edwardsville, Illinois, 62025, herein referred to as "Seller", and the City of Washington, Missouri, a municipal corporation hereinafter referred to as "City".

WITNESSETH: Whereas Seller was the best low bid received for furnishing of one Galion 430U SMS Truck Bed, Snowplow & Salt Spreader.

NOW THEREFORE, THE PARTIES HERETO AGREE AS FOLLOWS:

Seller agrees to provide to the City with one (1) Galion 430U SMS Truck Bed, Snowplow & Salt Spreader for payment in the total sum of Seventy-One Thousand Eight Hundred Sixty-Eight Dollars and Zero Cents (\$71,868.00).

The contract documents shall consist of the following:

- A. This Contract
- B. Signed copy of Ordinance
- C. General Specification and Bid

This contract, together with the other documents enumerated in this paragraph, forms the contract between the parties.

These documents are as fully a part of the contract as if attached hereto or repeated herein.

This agreement shall be construed or determined according to the laws of the State of Missouri.

IN TESTIMONY WHEREOF, Seller has hereunto set its hand, and the City of Washington executes this contract the day and year first written.

SELLER:

CITY:

BY: _____
Company Representative

BY: _____
Mayor – Washington, Missouri

ATTEST: _____
City Clerk



January 30, 2024

Honorable Mayor and City Council
City of Washington
405 Jefferson Street
Washington, MO 63090

RE: Recommendation – Use of MoDOT State Bid for the purchase of a 2-Ton Dump Truck with Snowplow & Salt Spreader

Honorable Mayor and City Council,

As you may be aware, before making a determination that a particular piece of equipment needs to be purchased, staff will annually review and analyze the equipment to determine the current requirement and the need for purchases. The new 2025 2-Ton Dump Truck with Snowplow & Salt Spreader is in the 2023-2024 budget in the amount of \$180,000. This would replace Truck #54 a 2010 International truck with Snowplow & Spreader.

Staff found that the MoDOT State Bid # 605CO23002393 would give the city the best pricing for this truck, from Truck Centers Inc. Troy IL. & the bed, snowplow & salt spreader from Woody's Municipal Supply Co., Edwardsville, IL.

The truck quote from Truck Centers Inc., is \$97,837, and we budgeted \$100,000. The Bed, Snowplow, and Spreader quote From Woody's Municipal Supply Co., is \$71,868, and we budgeted \$80,000. There will be separate contracts and ordinances for both companies due to there being a longer wait time for the bed, plow, & spreader, but they are both under the same MoDOT State Bid.

- I am recommending the New Freightliner 108S truck at \$97,837. This truck will replace truck #54 a 2010 International snowplow truck, with 35,200 miles. Although the miles are low, the truck has had numerous mechanical and corrosion issues. This also meets the 15-year equipment replacement recommendations. We will sell the 2010 International Truck #54 with plow and spreader together.
- I am also recommending the new Galion 430U SMS Bed, and the Buyers brand snowplow and salt spreader, at \$71,868, to replace the 2010 equipment,

As always, if you have any questions, concerns or would like additional information, please feel free to contact me prior to the City Council Workshop Meeting.

Respectfully,

Tony Bonastia
Street Superintendent
Washington MO

Woody's Municipal Supply Co.

"Leading the way in municipal sales and service"
PO Box 432 Office: 618-656-5404
 Edwardsville, IL 62025 Fax: 618-656-6105
 www.WoodysMunicipal.com

QUOTE - DO NOT PAY

Quote: 01-2257
 Date: 1/2/2024

PO:
 CustId: WASHINGTON C1

Cust Email:
 Phone: (636) 390-1030
 Salesperson: CGoclan
 User: TMoore

Bill To:

Washington, City of - MO
 405 Jefferson Street
 Washington, MO 63090

Ship To:

Washington, City of - MO

| Item | Type | Description | Qty | Tax | Price | Discount | Net Price |
|------------|------|---|--------|-----|-------------|----------|-------------|
| 430U SMS | QU | Galion 430U SMS | 1.0000 | | \$71,868.00 | | |
| | | Bod - 10' Steel Galion Dump Body | | | | | |
| | | 10" Extended pan: | | | | | |
| | | 2 ovals in rear posts: | | | | | |
| | | 30" Sides: | | | | | |
| | | 40" Front: | | | | | |
| | | 40" Rear: | | | | | |
| | | Back Up Alarm: | | | | | |
| | | Cabshield: Ovals facing forward for strobes | | | | | |
| | | Cabshield: 1/2 x 84" Integral | | | | | |
| | | Crossmemberless: | | | | | |
| | | Dirt shedding top rail: | | | | | |
| | | Double Fold Ladder: With hand rail | | | | | |
| | | D-rings: Welded inside front of body for spreader | | | | | |
| | | Floor: 3/16" AR450 | | | | | |
| | | Grab Handles: | | | | | |
| | | Hoist: G4-90-4.25-3 DA | | | | | |
| | | LED Light Kit: | | | | | |
| | | Longsills: 10" Formed Trapazoid | | | | | |
| | | Painted Red: | | | | | |
| | | Powder coat primed: | | | | | |
| | | Reflective Tape: both sides and tailgate | | | | | |
| | | Side Board Pockets: | | | | | |
| | | Side Bracing: V side bracing | | | | | |
| | | Steps: 1 step inside front drivers side | | | | | |
| | | Steps: Front Driver's side | | | | | |
| | | Structure: 7 Gauge AR450 | | | | | |
| | | Tailgate: 6 panel double acting Air Gate | | | | | |
| | | Tarp Rail: | | | | | |
| | | Zinc Primed: | | | | | |
| | | Total 430U SMS | | | | | \$71,868.00 |
| Load Sense | QU | Certified Hydraulics Load Sense | 1.0000 | | \$0.00 | | |
| | | Bod - Central Hydraulic System | | | | | |
| | | 30 Gallon Reservoir: | | | | | |
| | | Plow and Hoist Controls: Manual Cable with levers | | | | | |
| | | PTO: Hot Shift | | | | | |
| | | Spreader Control: Dual Knob | | | | | |

Woody's Municipal Supply Co.

"Leading the way in municipal sales and service"
 PO Box 432 Office: 618-656-5404
 Edwardsville, IL 62025 Fax: 618-656-6105
 www.WoodysMunicipal.com

QUOTE - DO NOT PAY

Quote: 01-2257
 Date: 1/2/2024

PO:
 CustId: WASHINGTON C1

Cust Email:
 Phone: (636) 390-1030
 Salesperson: CGoclan
 User: TMoore

Bill To:
 Washington, City of - MO
 405 Jefferson Street
 Washington, MO 63090

Ship To:
 Washington, City of - MO

| Item # | Qty | Description | Unit | Price | Total |
|------------------------------|-----------|--|---------------|---------------|---------------|
| Valve: Plow, Hoist, Spreader | | | | | |
| 16400420 | QU | Total Load Sense | | | \$0.00 |
| | | Buyers 16400420 | 1.0000 | \$0.00 | |
| | | Sno - Buyers Quick Link Plow Hitch | | | |
| | | 3 in lift cylinder: | | | |
| | | Cheek Plates: | | | |
| | | Quick Link Swivel Bar: | | | |
| | | Total 16400420 | | | \$0.00 |
| 1663A10202 | QU | Buyers 1663A10202 | 1.0000 | \$0.00 | |
| | | Sno - Plow Muni 11 x 36 HD Full Trip | | | |
| | | 12" Rubber Deflector: | | | |
| | | Jack Stand: | | | |
| | | Plow Markers: | | | |
| | | Quick Link Swivel Bar: | | | |
| | | Steel Cutting Edge: | | | |
| | | Total 1663A10202 | | | \$0.00 |
| 14510F505121GL1Z1 | QU | Buyers 14510F505121GL1Z1 | 1.0000 | \$0.00 | |
| | | Spr - Buyers 10 x 50 Stainless Steel Vbox Spreader | | | |
| | | 10 x 50: | | | |
| | | 20" Poly Spinner: | | | |
| | | 24" Chain: | | | |
| | | 304 Stainless: | | | |
| | | 4 Hinged Top Screens: | | | |
| | | 50:1 Hyd Motor: | | | |
| | | 7 Cubic Yards: | | | |
| | | Crank Up Chute: | | | |
| | | Folding Ladder: | | | |
| | | Inverted V: | | | |
| | | Ladder Mounted on rear: | | | |
| | | LED Spreader Light: | | | |
| | | Ratchet tie downs: | | | |
| | | Remote Grease Bank: | | | |
| | | Sloped Top Screens: | | | |
| | | SS Latch Bar: | | | |
| | | Total 14510F505121GL1Z1 | | | \$0.00 |
| Lighting | QU | Lighting | 1.0000 | \$0.00 | |
| | | Mis - Lighting | | | |
| | | 2 -15" Mini Light Bar: Federal Signal, 360 degree, amber/white LED Strobes | | | |
| | | 22.5 Curved Light bar: Mounted between mini, Work and flood Light | | | |
| | | Aluminum Action Bar: Cab Mounted | | | |

78

Woody's Municipal Supply Co.

"Leading the way in municipal sales and service"

PO Box 432 Office: 618-656-5404
 Edwardsville, IL 62025 Fax: 618-656-6105
 www.WoodysMunicipal.com

QUOTE - DO NOT PAY

Quote: 01-2257
 Date: 1/2/2024

PO:
 Custid: WASHINGTON C1

Cust Email:
 Phone: (636) 390-1030
 Salesperson: CGoclan
 User: TMoore

Bill To:

Washington, City of - MO
 405 Jefferson Street
 Washington, MO 63090

Ship To:

Washington, City of - MO

| | | | | | |
|--------------------|-----------|---|---------------|---------------|--------------------|
| | | Ecco 3265: Amber/Clear Strobes in rear post and cabshield | | | |
| | | Waterproof Junction Box: | | | |
| | | Wiring in conduit: | | | |
| | | Total Lighting | | | \$0.00 |
| Towing/Misc | QU | Towing/Misc | 1.0000 | \$0.00 | |
| | | Mis - Towing/Misc | | | |
| | | 1" Plate on rear: | | | |
| | | 2 D-rings: Mounted on plate | | | |
| | | 30 ton pintle: | | | |
| | | 7 pin trailer plug: | | | |
| | | 84" x 12' Vinyl Tarp: | | | |
| | | Aero Electric Tarp System: With Aluminum Guard, aluminum arms | | | |
| | | Body Vibrator: | | | |
| | | Mud Flaps: In front and behind rear wheels | | | |
| | | Total Towing/Misc | | | \$0.00 |
| | | | | Total: | \$71,868.00 |

| | | | |
|---------------|--|-----------------------|--------------------|
| Totals | | Sub Total: | \$71,868.00 |
| | | Total Tax: | \$0.00 |
| | | Invoice Total: | \$71,868.00 |

Quote good for 30 days



BILL NO. _____ INTRODUCED BY _____

ORDINANCE NO. _____

AN ORDINANCE REPEALING ORDINANCE NO. 24-13896 AND ENACTING IN LIEU THEREOF AN ORDINANCE AUTHORIZING AND DIRECTING THE EXECUTION OF AN AGREEMENT FOR STRAY ANIMAL BOARDING BY AND BETWEEN THE CITY OF WASHINGTON, MISSOURI AND THE FRANKLIN COUNTY HUMANE SOCIETY

BE IT ORDAINED by the Council of the City of Washington, Missouri, as follows:

SECTION 1: Ordinance No. 24-13896 is hereby repealed.

SECTION 2: The Mayor is hereby authorized and directed to execute an Agreement for Stray Animal Boarding by and between the City of Washington, Missouri and the Franklin County Humane Society, a copy of which is marked Exhibit A and is attached hereto and incorporated herein by reference, and such other documents, certificates and instruments as may be necessary or desirable to carry out and comply with the intent of this Ordinance, for and on behalf of and as the act and deed of the City. The City Clerk is hereby authorized and directed to attest to and affix the seal of the City to the said Agreement and such other documents, certificates and instruments as may be necessary or desirable to carry out and comply with the intent of this Ordinance.

SECTION 3: The City shall, and the officials, agents and employees of the City are hereby authorized and directed to, take such further action, and execute and deliver such other documents, certificates and instruments as may be necessary or desirable to carry out and comply with the intent of this Ordinance.

SECTION 4: All ordinances or parts of ordinances in conflict herewith are hereby repealed.

SECTION 5: This ordinance shall be in full force and effect from and after its passage and approval.

Passed: _____

ATTEST: _____

President of City Council

Approved: _____

ATTEST: _____

Mayor of Washington, Missouri

EXHIBIT A

AGREEMENT FOR STRAY ANIMAL BOARDING PROGRAM BETWEEN THE CITY OF WASHINGTON, MISSOURI AND FRANKLIN COUNTY HUMANE SOCIETY OF MISSOURI

THIS AGREEMENT (“Agreement”), made and entered into by and between the City of Washington, Missouri (hereinafter referred to as “City”), and the Franklin County Humane Society of Missouri (hereinafter referred to as “Society”), to wit:

PURPOSE:

The Society desires to contract with the City for stray animal boarding services in a reasonable amount, which will result in increased service to the citizens of the City, cost effectiveness to the City, and professional services in the area of stray animal boarding and treatment.

1. Commencing on the effective date of this Agreement, Society will provide and the City will accept the services of the Society for stray animal boarding for those animals found within the corporate limits of the City. The City shall pay Society the sum of \$35.00 per day up to a maximum of \$175.00 for the state-mandated five day hold plus a \$100.00 intake fee for each animal delivered by either the Police Department or a City resident. Society retains the sole discretion to accept or deny intake of any animal. Society shall charge City only actual days up to five days boarding, even in the event Society is legally required to hold an animal a full seven days in order to comply with statutory requirements. Society will provide City with an itemized monthly listing of the animals held and the locations at which they were found. City and Society may agree to amend these fees from time to time by written agreement signed by the parties which shall serve as an addendum to this Agreement.
2. The following procedures will apply:
 - a. In the event an animal is dropped off by a citizen, Society will obtain a signed voucher from the “finder” stating the citizen’s name/address/contact information, (as required by the Missouri Animal Care Facilities Act), and stating the exact location within the City where the animal was found.
 - b. Society and City will make reasonable efforts to determine whether the animal is stray versus an owned animal being surrendered by the owner.
 - c. Animals brought in by City and known or believed to be owned by a known owner shall be identified by City’s officers as such, and officer shall supply known owner contact information. The five day hold may be extended and a ten day hold fee may be assessed at Society’s discretion in order to give known

owner opportunity to collect the animal. Society will make reasonable efforts to contact the known owner via phone, letter, or email.

d. In the event City seizes an animal from the owner's property, state law requires City's officers to deliver a notice to the owner regarding the right to post bond for the animal's care. (Mo. Rev. Stat. §578.018). Delivery of the required notice shall be made by the City. City officer shall supply the Society special instructions or restrictions concerning the release of said animal to the owner.

e. In the event City desires to charge the owner a fee in connection with said animal, City shall arrange to collect said fee directly from the owner before owner is allowed to reclaim the animal from Society. City shall provide written instructions to Society, on City letterhead, as to the requirements and/or proof of payment of such fees with regard to owners reclaiming their pets.

f. At City's discretion, an officer may be dispatched to ascertain the owner's inability to pay. If owner is unable to pay fees and elects to surrender the animal to the shelter, the City will be charged for the boarding fees for the time the animal was considered a stray, not to exceed 5 business days.

g. When Society returns an animal to an owner, Society may, upon City's request, provide owner information to City police for the purpose of issuing citations to owners for violations of City's laws or State law, including but not limited to rabies tags requirements, leash laws, and neglect.

h. Society assumes legal ownership for all unclaimed animals according to the law, and assumes responsibility for the animal including ongoing care, vaccinations and medications, and re-adoption or euthanizing and disposal, at Society's sole discretion and expense.

i. Society shall not accept feral cats under this Agreement. If a citizen or City Officer presents a cat deemed feral by the Society, the citizen or Officer shall be informed of the Society's Trap, Neuter, and Return ("TNR") program and advised of the resources and assistance the Society may provide pursuant to its TNR policy.

3. In order to assure the visiting public's safety, Society cannot accept animals that are vicious or are subject to bite or rabies holds due to the absence of a secure, private area in which to house these animals. Holds of this nature should be done by a Veterinarian. Similarly, if an animal is injured and life is threatened by the injury, the animal should be taken to the nearest Veterinarian for trauma care as Society is not equipped as a trauma center.

4. Society provides City with after-hours drop-off privileges for City officers only. Dogs must be secured in a pen and cats must be secured in a crate. Officers must complete the surrender statement in its entirety and re-secure the premises. City will not direct citizens to perform after-hours drop-offs.
5. Any necessary administrative or procedural changes, which may occur from time to time during the period of the contract, shall be administered between the Chief of Police or City Administrator for the City and the Executive Director or President of the Board of Directors of the Society.
6. Each party hereunto states that it is an equal opportunity employer and does not unlawfully discriminate in employment or service.
7. The Society shall provide an insurance policy naming the City as additional insured in the amount of no less than one hundred thousand dollars (\$100,000) per occurrence. The Society agrees to hold harmless, indemnify and defend the City and its officers, employees and agents for any and all liability of any type relating to any actions or omissions of the Society, its officers, employees or agents, including costs and attorney fees.
8. This Agreement may be cancelled by the agreement of both parties or by one party giving sixty (60) days written notice of termination.
9. The term of this Agreement shall be from December 1, 2023, through December 31, 2026.
10. Copies of this agreement shall be on file with the City Clerk and Society.
11. This Agreement shall constitute the entire agreement of the parties.
12. This Agreement may be executed in counterpart.

IN WITNESS WHEREOF, the parties hereto have executed this Agreement as follows:

CITY OF WASHINGTON, MISSOURI

By: James D. Hagedorn, Mayor

Date _____

ATTEST:

Sherri Klekamp, City Clerk

FRANKLIN COUNTY HUMANE SOCIETY OF MISSOURI

Title: _____

_____ Date

BILL NO. _____ INTRODUCED BY _____

ORDINANCE NO. _____

AN ORDINANCE AUTHORIZING AND DIRECTING THE
EXECUTION OF A CONTRACT AMENDMENT NO. 1 BY
AND BETWEEN THE CITY OF WASHINGTON, MISSOURI
AND COCHRAN

BE IT ORDAINED by the Council of the City of Washington, Missouri, as follows:

SECTION 1: The Mayor is hereby authorized and directed to execute a Contract Amendment NO. 1 by and between the City of Washington, Missouri and Cochran, a copy of which is marked Exhibit A and is attached hereto and incorporated herein by reference, and such other documents, certificates and instruments as may be necessary or desirable to carry out and comply with the intent of this Ordinance, for and on behalf of and as the act and deed of the City. The City Clerk is hereby authorized and directed to attest to and affix the seal of the City to the said Amendment and such other documents, certificates and instruments as may be necessary or desirable to carry out and comply with the intent of this Ordinance.

SECTION 2: The City shall, and the officials, agents and employees of the City are hereby authorized and directed to, take such further action, and execute and deliver such other documents, certificates and instruments as may be necessary or desirable to carry out and comply with the intent of this Ordinance.

SECTION 3: All ordinances or parts of ordinances in conflict herewith are hereby repealed.

SECTION 4: This ordinance shall be in full force and effect from and after its passage and approval.

Passed: _____

ATTEST: _____

President of City Council

Approved: _____

ATTEST: _____

Mayor of Washington, Missouri



CONTRACT AMENDMENT

Amendment No.: 1

Date: January 18, 2024

Project No.: 23-9481

Name of Project: Oldenburg Industrial Park Infrastructure

Client: City of Washington

The following revisions are hereby made to the Contract:

1. The sanitary sewer lift station was upgraded from a duplex to a triplex station which was not anticipated in the initial project scope. A phased approach to the lift station design and analysis was also performed which will allow for expansion in the future as the park develops, but will prevent over-build of the lift station during the initial construction for Phase I of the park.
2. Plan revisions and coordination resulting from substantial permitting with the Corps of Engineers for the two creek crossings. The scope revisions include additional meetings and drawings required by the Corps that were not anticipated in the initial project scope.

Original Contract Price: \$ 156,185.00

Original Contract Date: January 25, 2023

Current Contract Price adjusted by previous Contract Amendment: \$ N/A

The Contract Price due to this Contract Amendment will be increased **by:** \$ \$13,750.00
(increased / decreased)

The new Contract Price including this Contract Amendment will be: \$ \$169,935.00

The Contract Time will be N/A **by** N/A **calendar days.**
(increased / decreased)

Approved by: *Elliot R. Reed* 01/18/2024
Cochran Date

Accepted by: _____
Client Date

Th



January 24, 2024

Mayor & City Council
City of Washington
Washington, MO 63090

Re: Change Order – Cochran Engineering Contract

Mayor & City Council,

On your agenda for the February 5th meeting is an ordinance amending the contract with Cochran Engineering for the Oldenburg Industrial Park Improvements. There were increases in the scope to the lift station as well as multiple plan revisions that were the results of the Corps of Engineers requirements for the creek crossings. It increases the contract \$13,750 to a total of \$169,935.

There is enough money in the economic development CIST budget for this year to cover the increase. Staff recommends approval.

Feel free to reach out with any questions.

Sincerely,

A handwritten signature in black ink that reads "Sal Maniaci".

Sal Maniaci
Community and Economic Development Director

BILL NO. _____ INTRODUCED BY _____

ORDINANCE NO. _____

AN ORDINANCE APPROVING A BOUNDARY
ADJUSTMENT FOR HIGHLAND MEADOWS, PLAT 9A
IN THE CITY OF WASHINGTON, FRANKLIN
COUNTY, MISSOURI

WHEREAS, the plat, attached as Exhibit A demonstrating the boundary adjustment
in the City of Washington, Missouri has been submitted to the City for approval; and

WHEREAS, said plat meets the requirements of the applicable ordinances of the
City of Washington, Missouri.

NOW, THEREFORE, be it ordained by the Council of the City of Washington,
Missouri, as follows:

SECTION 1: The boundary adjustment as shown in the attached Exhibit A in the
City of Washington, Missouri is hereby approved.

SECTION 2: All ordinances or parts of ordinances in conflict herewith are hereby
repealed.

SECTION 3: This ordinance shall be in full force and effect from and after its
passage and approval.

Passed: _____

ATTEST: _____

President of City Council

Approved: _____

ATTEST: _____

Mayor of Washington, Missouri

Exhibit A

HIGHLAND MEADOWS PLAT 9A

A RE-SUBDIVISION OF LOTS A1 & A2
 HIGHLAND MEADOWS PLAT 9
 NW 1/4 SECTION 28 T48N R1W, WASHINGTON,
 FRANKLIN COUNTY, MISSOURI
 JANUARY 30, 2024

A SUBDIVISION LOCATED IN THE NORTHEAST QUARTER OF SECTION 28 T48N R1W IN WASHINGTON, FRANKLIN COUNTY, MISSOURI, BEING LOTS A1 AND A2 OF HIGHLAND MEADOWS PLAT 9 RECORDED IN DOCUMENT NO. 2308503 AND CONTAINING 11.28 ACRES.

THESE LOTS ARE SUBJECT TO EASEMENTS DEDICATED BY THE PLAT OF HIGHLAND MEADOWS PLAT 8 AND HIGHLAND MEADOWS PLAT 9. I THEM SUBDIVIDED LOTS A1 AND A2 OF HIGHLAND MEADOWS PLAT 9 RECORDED IN DOCUMENT NO. 2308503 INTO TWO LOTS AS SHOWN ON THE FACE OF THE PLAT.

THIS URBAN PROPERTY HAS BEEN SURVEYED AND SUBDIVIDED IN ACCORDANCE WITH THE CURRENT MISSOURI MINIMUM STANDARDS FOR PROPERTY BOUNDARY SURVEYS.

ENGINEERING SURVEYS & SERVICES
 MISSOURI L.L.C. CORP. #200404672
 1113 FAY STREET
 COLUMBIA, MO 65201
 PHONED: (620) 449-2646
 EMAIL: FCARROZBESS-INC.COM



Frederick E. Carroz
 FREDERICK E. CARROZ III
 PROFESSIONAL LAND SURVEYOR
 PLS - 2008018655

RIVERBEND ESTATES II, L.P.
 NW 1/4 SECTION 28 T48N R1W
 WASHINGTON, FRANKLIN COUNTY, MISSOURI

I, JEFFREY E. SMITH, MANAGER OF COUNTRY CLUB PROPERTIES, L.L.C., OWNER OF LOT A1 SHOWN HEREON, HAVE CAUSED THE SAME TO BE SURVEYED AND RE-SUBDIVIDED INTO LOTS IN THE MANNER SHOWN HEREON.

THE FIRE LANE, INGRESS/EGRESS EASEMENT SHOWN ON THE PLAT IS HEREBY GRANTED TO THE CITY OF WASHINGTON FOR THE USE BY EMERGENCY PERSONNEL AS AN INGRESS/EGRESS EASEMENT AND AS A FIRE LANE ACCESS FOR EMERGENCY SERVICES INCLUDING BUT NOT LIMITED TO FIRE, POLICE, AND AMBULANCE, AND SHALL BE PERPETUALLY MAINTAINED BY THE PROPERTY OWNER.

ALL LOTS IN THIS SUBDIVISION ARE HEREBY SUBJECT TO THE RESTRICTIONS AND CONDITIONS SET FORTH IN AN INSTRUMENT RECORDED IN DOCUMENT NO. 1515076 IN THE OFFICE OF THE RECORDER OF DEEDS.

IN WITNESS WHEREOF, I HAVE HERETO SET MY HAND THIS ____ DAY OF _____, 2024.
 COUNTRY CLUB PROPERTIES, L.L.C.

JEFFREY E. SMITH, MANAGER

STATE OF MISSOURI)
 COUNTY OF BOONE) SS

ON THIS ____ DAY OF _____, 2024 BEFORE ME PERSONALLY APPEARED JEFFREY E. SMITH, MANAGER OF COUNTRY CLUB PROPERTIES, L.L.C., TO ME KNOWN TO BE THE PERSON DESCRIBED IN AND WHO EXECUTED THE WITHIN SUBDIVISION ON BEHALF OF SAID LIMITED LIABILITY COMPANY AND ACKNOWLEDGED TO ME THAT HE EXECUTED THE SAME FOR THE PURPOSES THEREIN STATED AND ACKNOWLEDGED THAT HE EXECUTED THE SAME AS HIS FREE ACT AND DEED.

IN TESTIMONY WHEREOF, I HAVE HERETO SET MY HAND AND AFFIXED MY OFFICIAL SEAL IN THE COUNTY AND STATE AFORESAID, THE DAY AND YEAR FIRST ABOVE WRITTEN.

NOTARY PUBLIC

I, CURT NEUENSWANDER, AUTHORIZED SIGNER FOR RIVERBEND ESTATES II, L.P., AND MOCAP PROPERTIES, L.L.C., OWNERS OF LOT A2 SHOWN HEREON, HAVE CAUSED THE SAME TO BE SURVEYED AND RE-SUBDIVIDED INTO LOTS IN THE MANNER SHOWN HEREON.

THE FIRE LANE, INGRESS/EGRESS EASEMENT SHOWN ON THE PLAT IS HEREBY GRANTED TO THE CITY OF WASHINGTON FOR THE USE BY EMERGENCY PERSONNEL AS AN INGRESS/EGRESS EASEMENT AND AS A FIRE LANE ACCESS FOR EMERGENCY SERVICES INCLUDING BUT NOT LIMITED TO FIRE, POLICE, AND AMBULANCE, AND SHALL BE PERPETUALLY MAINTAINED BY THE PROPERTY OWNER.

ALL LOTS IN THIS SUBDIVISION ARE HEREBY SUBJECT TO THE RESTRICTIONS AND CONDITIONS SET FORTH IN AN INSTRUMENT RECORDED IN DOCUMENT NO. 1513075 IN THE OFFICE OF THE RECORDER OF DEEDS.

IN WITNESS WHEREOF, I HAVE HERETO SET MY HAND THIS ____ DAY OF _____, 2024.
 RIVERBEND ESTATES II, L.P.
 BY: MOCAP PROPERTIES, L.L.C.

CURT NEUENSWANDER

STATE OF MISSOURI)
 COUNTY OF BOONE) SS

ON THIS ____ DAY OF _____, 2024 BEFORE ME PERSONALLY APPEARED CURT NEUENSWANDER, AUTHORIZED SIGNER FOR RIVERBEND ESTATES II, L.P., AND MOCAP PROPERTIES, L.L.C., TO ME KNOWN TO BE THE PERSON DESCRIBED IN AND WHO EXECUTED THE WITHIN SUBDIVISION ON BEHALF OF SAID LIMITED PARTNERSHIP AND SAID LIMITED LIABILITY COMPANY, ACKNOWLEDGED TO ME THAT HE EXECUTED THE SAME FOR THE PURPOSES THEREIN STATED AND ACKNOWLEDGED THAT HE EXECUTED THE SAME AS HIS FREE ACT AND DEED.

IN TESTIMONY WHEREOF, I HAVE HERETO SET MY HAND AND AFFIXED MY OFFICIAL SEAL IN THE COUNTY AND STATE AFORESAID, THE DAY AND YEAR FIRST ABOVE WRITTEN.

NOTARY PUBLIC

I, SHERRI KLEKAMP, CITY CLERK FOR AND WITHIN THE CITY OF WASHINGTON, MISSOURI, DO HEREBY CERTIFY THAT THE PLAT OF HIGHLAND MEADOWS PLAT 9A WAS APPROVED, AND THE 35 FOOT CROSS ACCESS AND UTILITY EASEMENT, THE 30 FOOT CROSS ACCESS EASEMENT, AND THE 37 FOOT CROSS ACCESS AND UTILITY EASEMENT DEDICATED PER HIGHLAND MEADOWS PLAT 9 RECORDED IN DOCUMENT NO. 2308503 IS HEREBY VACATED BY THE CITY COUNCIL OF WASHINGTON, MISSOURI, BY ORDINANCE NO. _____, PASSED AND APPROVED THE ____ OF _____, 2024.

IN TESTIMONY WHEREOF, I HAVE HERETO SET MY HAND AND AFFIXED MY OFFICIAL SEAL OF THE CITY OF WASHINGTON, MISSOURI, THIS ____ DAY OF _____, 2024.

SHERRI KLEKAMP, CITY CLERK
 WASHINGTON, MISSOURI

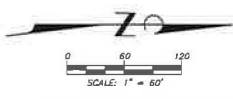
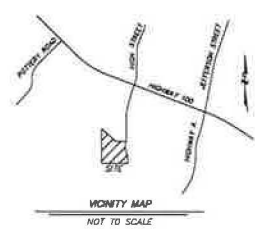

BEARINGS ARE REFERENCED TO MISSOURI STATE PLAIN COORDINATE SYSTEM (NAD 1983) CENTRAL ZONE.

MONUMENT LEGEND
 G- IRON
 S- SET
 DTP- DEDICATED THIS PLAT

ALL MONUMENTS ARE FOUND UNLESS SHOWN (S) SET

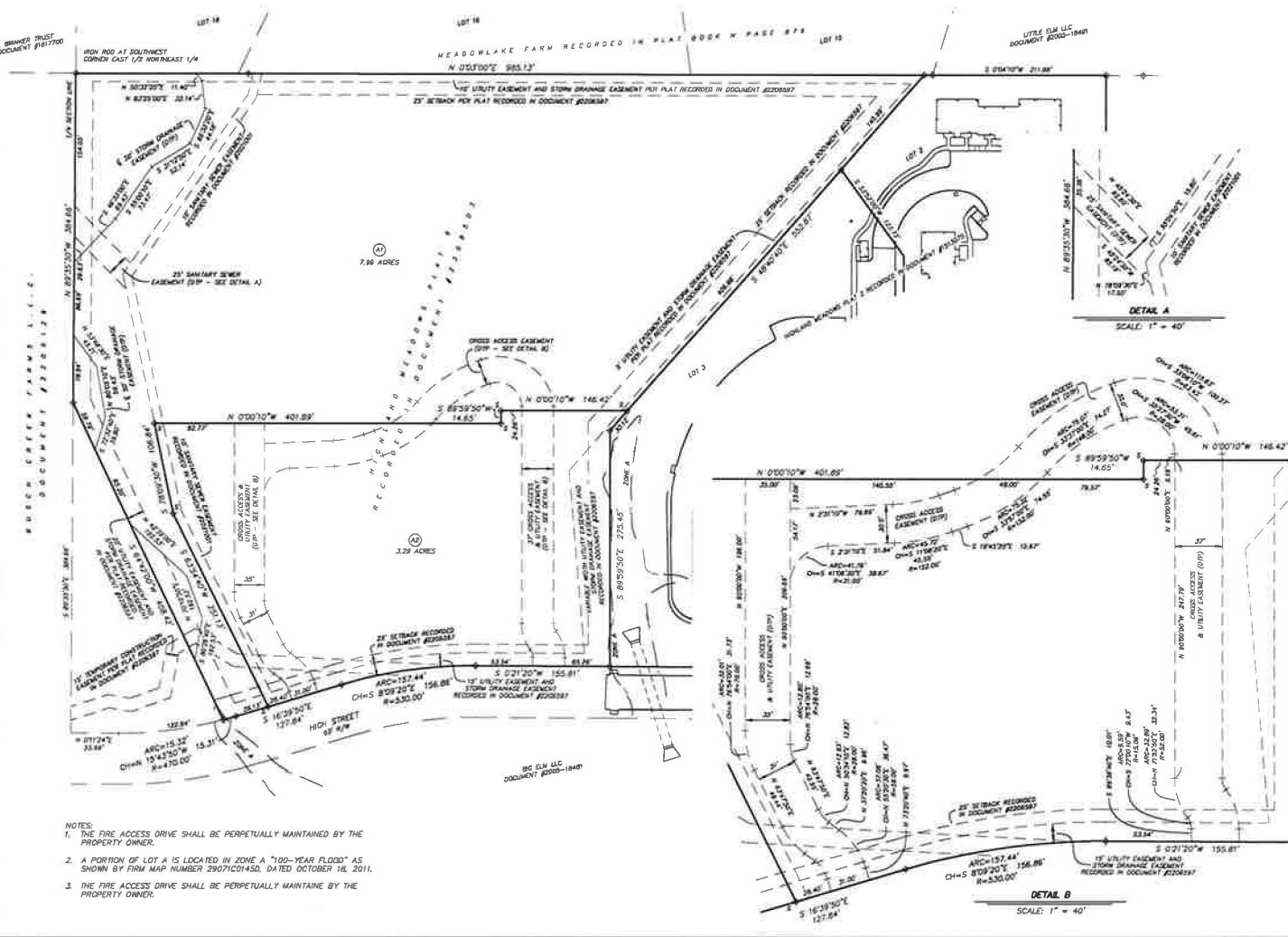

- NOTES:
 1. THE FIRE ACCESS DRIVE SHALL BE PERPETUALLY MAINTAINED BY THE PROPERTY OWNER.
 2. A PORTION OF LOT A IS LOCATED IN ZONE A "100-YEAR FLOOD" AS SHOWN BY FIRM MAP NUMBER 29071C01450, DATED OCTOBER 16, 2011.
 3. THE FIRE ACCESS DRIVE SHALL BE PERPETUALLY MAINTAINED BY THE PROPERTY OWNER.

7i



February 5, 2024

Mayor & City Council
City of Washington
Washington, MO 63090

Re: Highland Meadows Plat 9A

Mayor & City Council,

On your agenda for the meeting February 5, 2024 is an ordinance approving a boundary adjustment for a recently approved boundary adjustment of Highland Meadows Plat 9A. The applicant resurveyed the area and found a transformer in the middle of the north entrance which required a slight adjustment to the access easement.

Feel free to reach out with any questions.

Sincerely,

Sarah Skeen

Sarah Skeen
City Planner/GIS Specialist
Zoning and Planning Department



OFFICE: 123 LAFAYETTE STREET | WASHINGTON, MO 63090
CORRESPONDENCE: PO BOX 144 | WASHINGTON, MO 63090
636.239.1743 | INFO@DOWNTOWNWASHMO.ORG

Year in Review

2023

 53 NET NEW EMPLOYEES DOWNTOWN

INVESTED \$3,162,164
IN PRIVATE IMPROVEMENTS
INCLUDES INFORMATION FROM PERMIT REPORTS FOR
COMMERCIAL AND RESIDENTIAL IMPROVEMENTS



 INVESTED \$387,500
IN PUBLIC IMPROVEMENTS

9,500 VOLUNTEER HOURS
380 HOURS AT CLEAN UP DAY 

 HELD 27 DAYS OF
COMMUNITY EVENTS

COMMUNITY GRANTS AWARDED
DOWNTOWN WASHINGTON, INC. MERCHANT GRANT
DOWNTOWN RIVERFRONT PLAYGROUND PROJECT
DOWNTOWN WASHINGTON, INC. SIGN & AWNING GRANT



 VOLUNTEERS, BOARD
MEMBERS, & STAFF
ATTENDED 8 TRAININGS

HOSTED BY MISSOURI MAIN STREET CONNECTION, MAIN STREET
AMERICA, AND THE NATIONAL TRUST FOR HISTORIC PRESERVATION.

24,724 SOCIAL MEDIA FOLLOWERS
17.5% GROWTH ACROSS ALL PLATFORMS COMPARED TO 2022

49,000 WEBSITE VISITS
23% INCREASE IN TRAFFIC COMPARED TO 2022



OVER 260,000 IMPRESSIONS
THROUGH TV ADVERTISING
DOWNTOWN WASHINGTON COMMERCIALS REACHED
RESIDENTS OF CRAWFORD, PHELPS, FRANKLIN, CLAY,
ST. CHARLES, LINCOLN, WARREN, & ST. LOUIS COUNTIES.



\$68,280 IN GIFT CERTIFICATE SALES
THESE GIFTED DOLLARS STAY IN THE WASHINGTON AREA, STIMULATING
THE LOCAL ECONOMY. REDEEMABLE AT OVER 90 LOCAL BUSINESSES.



BUSINESSES & PROPERTIES OPENED OR RELOCATED

- RESOLUTIONS TITLE - OPENED FEBRUARY 2023
- THE VOID TATTOO - OPENED FEBRUARY 2023
- THE AXE DEPOT - OPENED MARCH 2023
- THE ALLEY NEXT LEVEL - OPENED MARCH 2023
- VINTAGE BEAUTY BAR - OPENED MARCH 2023
- THE CELLAR AT OAK & FRONT - OPENED APRIL 2023
- WANDERLUST MARKET - OPENED JULY 2023
- PRISMA MEDSPA & ESTHETICS - OPENED JULY 2023
- MAIN ST. REAL ESTATE - OPENED SEPTEMBER 2023
- EUPHORIA RAGE & PAINT ROOM - OPENED OCTOBER 2023
- GRIT & GRACE CHILDREN'S BOUTIQUE - OPENED OCTOBER 2023
- GALACTIC GIDDY UP TATTOO - OPENED OCTOBER 2023
- ELS REAL ESTATE GROUP - OPENED OCTOBER 2023
- SERENDIPITY SLUSH CO. - OPENED NOVEMBER 2023
- PURE BEAUTY MED SPA - OPENED NOVEMBER 2023
- LIBERTY HALL MICRO-SUITES
 - TRUE HAIR THERAPY STUDIO - OPENED DECEMBER 2023
 - CHRISTINE NEWTON BEAUTY - OPENED OCTOBER 2023
 - SALON GENESIS - OPENED OCTOBER 2023
 - GLOSS NAIL SALON - OPENED NOVEMBER 2023

BUSINESSES MOVED IN 2023

- PHOTOGENICS ON LOCATION - MOVED LOCATIONS 2023
- BIRDIE'S BAKESHOP - MOVED LOCATIONS 2023
- TRASHY ROOTS - MOVED LOCATIONS 2023

HERE'S TO ANOTHER GREAT YEAR!

BILL NO. _____ INTRODUCED BY _____

ORDINANCE NO. _____

AN ORDINANCE APPROVING THE FINAL PLAT OF STONE BRIDGE,
PLAT 1 IN THE CITY OF WASHINGTON, FRANKLIN COUNTY, MISSOURI

WHEREAS, the final plat of Stone Bridge Plat 1 in the City of Washington,
Franklin County, Missouri, has been submitted to the City for approval; and

WHEREAS, the City Clerk and City Engineer have certified that the required
improvements have not been completed; however, a Performance Contract is attached
hereto and marked as Exhibit A to see that they shall be completed per the City Code.

NOW, THEREFORE, be it ordained by the Council of the City of Washington,
Missouri, as follows:

SECTION 1: The final plat of Stone Bridge, Plat 1 in the City of Washington,
Missouri, is hereby approved and the same is ordered recorded with the Franklin County,
Missouri, Recorder of Deeds.

SECTION 2: All ordinances or parts of ordinances in conflict herewith are hereby
repealed.

SECTION 3: This ordinance shall be in full force and effect from and after its
passage and approval.

Passed: _____

ATTEST: _____

President of City Council

Approved: _____

ATTEST: _____

Mayor of Washington, Missouri

Exhibit A

PERFORMANCE CONTRACT

Whereas, the Code of the City of Washington, Missouri provides in Section 410.035(G)(5) that all minimum improvements shall be installed and approved in a subdivision before the final plat of the subdivision is submitted to the City of Washington, Missouri, unless written approval is given by the City Council to complete said improvements as the subdivision is developed; and

Whereas, pursuant to Section 410.035(G)(5), in lieu of the completion of the minimum improvements previous to the final approval of a plat, the City Council shall accept, at the option of the developer, an escrow secured with cash or an irrevocable letter of credit deposited with the City, or the City may accept a surety bond and such bond shall be in an amount and with surety and other reasonable conditions, providing for and securing the actual construction and installation of the minimum improvements; and

Whereas, the undersigned owner has requested the City Council of the City of Washington, Missouri, to grant final plat approval of "Stone Bridge, Plat 1", even though all minimum improvements have not been installed and approved; and

Whereas, the City Engineer has determined that the amount of One Hundred Sixty Three Thousand (\$163,000.00) is equal to the cost of constructing, erecting and installing all improvements and utilities as shown on the Subdivision Improvement Plans not yet constructed, erected and installed.

Now, Therefore, in consideration of the acceptance and final plat approval by the City Council of the City of Washington, Missouri, of the "Stone Bridge, Plat 1", and in accordance with Section 410.035(G)(5) of the Code of the City of Washington, Missouri, the undersigned hereby agrees to furnish the City of Washington, Missouri, at the undersigned's option, an irrevocable letter of credit or an escrow secured with cash, in the amount One Hundred Sixty Three Thousand Dollars (\$163,000.00), equal to the cost of constructing, erecting and installing all improvements and utilities as shown on the Subdivision Improvement Plans not yet constructed, erected and installed, as determined by the City Engineer. The City of Washington, Missouri may accept, in lieu of an irrevocable letter of credit or an escrow secured with cash, a surety bond with surety in an amount and with surety and other reasonable conditions, providing for and securing the

actual construction and installation of the improvements and utilities shown on the Subdivision Improvement Plans not yet constructed, erected and installed as determined by the City Engineer.

It is further understood and agreed the undersigned shall complete construction and installation of the improvements and shown on the Subdivision Improvement Plans not yet constructed, erected and installed as determined by the City Engineer within twenty four (24) months of the date hereof.

It is further understood and agreed to that no utility service connections or occupancy permits shall be issued to the owner, or to any other person, firm, corporation, association or partnership, for any structure, unless and until all utilities and improvements have been constructed, erected and installed in said structure and upon lots on which said structure is situated in accordance with the Subdivision Improvement Plans.

It is hereby further understood and agreed that no occupancy permit shall be issued to the owner or any other person, firm, corporation, association or partnership for any structure on any street that is not completed in front of or adjacent to such lots upon which such structure is situated.

Dated this _____ day of _____, 2024.

Owner/Subdivider/Divider/Applicant

Name and Title

Company Name

City of Washington, Missouri

Mayor

Seal:

Attest:

City Clerk

CITY OF WASHINGTON
CITY SALES TAX SUMMARY

1% GENERAL SALES TAX

| | | | | | |
|--|-----------------|-------------------------|-----------------|-----------|--------------------------|
| Previous Years 1970-2000 Total: | | \$ 36,121,362.69 | | | |
| 2000-2001 | \$ 2,614,947.25 | 2010-2011 | \$ 3,613,372.27 | 2020-2021 | \$ 5,138,337.05 |
| 2001-2002 | 2,665,810.02 | 2011-2012 | 3,698,652.72 | 2021-2022 | 5,475,936.43 |
| 2002-2003 | 2,875,714.84 | 2012-2013 | 3,760,065.80 | 2022-2023 | 5,586,805.95 |
| 2003-2004 | 3,155,590.86 | 2013-2014 | 3,912,118.45 | 2023-2024 | 1,801,010.09 |
| 2004-2005 | 3,187,693.12 | 2014-2015 | 4,204,694.99 | | |
| 2005-2006 | 3,345,292.87 | 2015-2016 | 4,397,905.50 | | |
| 2006-2007 | 3,445,234.45 | 2016-2017 | 4,354,507.85 | | |
| 2007-2008 | 3,773,268.98 | 2017-2018 | 4,703,065.67 | | |
| 2008-2009 | 3,556,222.39 | 2018-2019 | 4,612,283.40 | | |
| 2009-2010 | 3,497,829.39 | 2019-2020 | 4,787,670.81 | | |
| TOTAL COLLECTIONS TO DATE: | | | | | \$ 128,285,393.84 |

| MONTH | 2018-2019 | 2019-2020 | 2020-2021 | 2021-2022 | 2022-2023 | 2023-2024 | Monthly % Increase/ (Decrease) |
|----------------|------------------------|------------------------|------------------------|------------------------|------------------------|------------------------|-----------------------------------|
| OCTOBER | \$ 341,934.38 | \$ 347,786.52 | \$ 387,415.44 | \$ 454,143.50 | \$ 404,210.90 | \$ 451,517.96 | 11.70% |
| NOVEMBER | 273,682.85 | 325,999.08 | 337,510.28 | 329,477.61 | 439,267.24 | 394,809.57 | -10.12% |
| DECEMBER | 406,617.65 | 400,738.68 | 448,383.63 | 522,976.40 | 469,140.53 | 513,793.63 | 9.52% |
| JANUARY | 428,005.85 | 420,055.36 | 430,457.12 | 392,285.39 | 515,227.78 | 440,888.93 | -14.43% |
| FEBRUARY | 363,771.00 | 417,204.79 | 396,723.58 | 509,008.53 | 495,173.79 | | |
| MARCH | 444,964.47 | 417,215.47 | 468,305.25 | 483,461.03 | 400,841.38 | | |
| APRIL | 387,311.51 | 365,080.95 | 387,138.97 | 393,317.74 | 476,640.26 | | |
| MAY | 300,584.29 | 358,920.74 | 385,747.95 | 342,734.14 | 407,267.67 | | |
| JUNE | 456,577.00 | 401,315.24 | 514,849.48 | 536,473.31 | 490,570.26 | | |
| JULY | 420,349.19 | 442,261.53 | 462,011.90 | 462,478.68 | 476,993.66 | | |
| AUGUST | 322,712.79 | 372,615.14 | 396,711.64 | 546,440.92 | 498,392.59 | | |
| SEPTEMBER | 465,772.42 | 518,477.31 | 523,081.81 | 503,139.18 | 513,079.89 | | |
| TOTALS: | \$ 4,612,283.40 | \$ 4,787,670.81 | \$ 5,138,337.05 | \$ 5,475,936.43 | \$ 5,586,805.95 | \$ 1,801,010.09 | |

Increase (Decrease)
Over Prior Year -1.93% 3.80% 7.32% 6.57% 2.02%

OVERALL PERCENTAGE GROWTH/
(REDUCTION) FOR OCTOBER TO
PRESENT:

-1.47%

FISCAL YEAR END PERCENTAGE
(POS- OCTOBER TO SEPTEMBER)
Shown Once A Year on November Report.

0.00%

1/2 % CAPITAL IMPROVEMENT SALES TAX

EFFECTIVE: 07-01-89

| | | |
|-------------------|-----------|------------------|
| EXPIRED: 06-30-94 | 1989-1994 | \$ 4,111,148.43 |
| EXPIRED: 06-30-02 | 1994-2002 | 9,410,782.24 |
| EXPIRED: 06-30-10 | 2002-2010 | 13,334,617.88 |
| EXPIRED: 06-30-18 | 2010-2018 | 15,975,018.36 |
| EXPIRES: 06-30-26 | 2018-2026 | \$ 14,338,595.25 |

TOTAL COLLECTIONS TO DATE: \$ 57,170,162.16

| MONTH | 2018-2019 | 2019-2020 | 2020-2021 | 2021-2022 | 2022-2023 | 2023-2024 | Monthly % Increase/ (Decrease) |
|---------------|------------------------|------------------------|------------------------|------------------------|------------------------|----------------------|--------------------------------------|
| OCTOBER | \$ 170,966.92 | \$ 173,893.15 | \$ 193,707.79 | \$ 227,071.73 | \$ 202,105.70 | \$ 225,758.59 | 11.70% |
| NOVEMBER | 136,841.76 | 162,999.67 | 168,755.25 | 164,738.68 | 219,633.65 | 197,405.06 | -10.12% |
| DECEMBER | 203,310.25 | 200,369.28 | 224,192.00 | 261,488.24 | 234,570.17 | 256,897.15 | 9.52% |
| JANUARY | 214,002.88 | 210,027.68 | 215,228.64 | 196,142.72 | 257,613.79 | 220,444.46 | -14.43% |
| FEBRUARY | 181,885.56 | 208,602.53 | 198,361.30 | 254,504.01 | 247,587.18 | | |
| MARCH | 222,481.70 | 208,607.73 | 234,152.34 | 241,730.89 | 200,420.71 | | |
| APRIL | 193,656.33 | 182,540.31 | 193,569.47 | 196,659.57 | 238,319.46 | | |
| MAY | 150,291.55 | 179,460.29 | 192,873.68 | 171,366.64 | 203,633.58 | | |
| JUNE | 228,288.80 | 200,657.51 | 257,424.63 | 268,236.68 | 245,285.14 | | |
| JULY | 210,175.01 | 221,130.97 | 231,006.12 | 231,239.74 | 238,497.27 | | |
| AUGUST | 161,356.40 | 186,307.76 | 198,355.48 | 273,220.21 | 249,196.84 | | |
| SEPTEMBER | 232,886.54 | 259,238.60 | 261,541.37 | 251,569.17 | 256,539.82 | | |
| TOTALS | \$ 2,306,143.70 | \$ 2,393,835.48 | \$ 2,569,168.07 | \$ 2,737,968.28 | \$ 2,793,403.31 | \$ 900,505.26 | |

Increase
(Decrease) Over
Prior Year

-1.93% 3.80% 7.32% 6.57% 2.02%

OVERALL PERCENTAGE GROWTH/
(REDUCTION) FOR OCTOBER TO
PRESENT:

-1.47%

FISCAL YEAR END PERCENTAGE
(POS- OCTOBER TO SEPTEMBER)
Shown Once A Year on November
Report.

1/2 % TRANSPORTATION SALES TAX

| MONTH | 2018-2019 | | 2019-2020 | | 2020-2021 | | 2021-2022 | | 2022-2023 | | 2023-2024 | Monthly % Increase/ (Decrease) |
|-----------|-----------------|-----------------|-----------------|-----------------|-----------------|---------------|-----------|--|-----------|--|-----------|--------------------------------------|
| OCTOBER | \$ 170,946.23 | \$ 173,893.15 | \$ 193,707.83 | \$ 227,070.97 | \$ 202,105.68 | \$ 225,758.66 | | | | | 11.70% | |
| NOVEMBER | 136,840.50 | 162,999.68 | 168,755.33 | 164,738.72 | 219,633.66 | 197,404.90 | | | | | -10.12% | |
| DECEMBER | 203,308.99 | 200,369.28 | 224,192.04 | 261,488.24 | 234,570.22 | 256,897.35 | | | | | 9.52% | |
| JANUARY | 214,002.88 | 210,027.78 | 215,228.70 | 196,142.69 | 257,613.79 | 220,444.42 | | | | | -14.43% | |
| FEBRUARY | 181,885.52 | 208,602.55 | 198,361.35 | 254,499.40 | 247,587.19 | | | | | | | |
| MARCH | 222,481.85 | 208,607.77 | 234,152.35 | 241,730.92 | 200,420.73 | | | | | | | |
| APRIL | 193,656.25 | 182,540.19 | 193,569.46 | 196,659.56 | 238,319.52 | | | | | | | |
| MAY | 150,291.51 | 179,460.32 | 192,873.68 | 171,366.53 | 203,633.50 | | | | | | | |
| JUNE | 228,288.78 | 200,657.52 | 257,424.62 | 268,236.76 | 245,285.23 | | | | | | | |
| JULY | 210,175.04 | 221,130.96 | 231,006.14 | 231,239.69 | 238,497.24 | | | | | | | |
| AUGUST | 161,355.80 | 186,307.86 | 198,355.50 | 273,220.19 | 249,196.88 | | | | | | | |
| SEPTEMBER | 232,886.52 | 259,238.63 | 261,541.35 | 251,569.36 | 256,539.78 | | | | | | | |
| TOTALS | \$ 2,306,119.87 | \$ 2,393,835.69 | \$ 2,569,168.35 | \$ 2,737,963.03 | \$ 2,793,403.42 | \$ 900,505.33 | | | | | | |

Increase (Decrease) Over Prior Year

| | | | | | |
|--|--------|-------|-------|-------|-------|
| | -1.93% | 3.80% | 7.32% | 6.57% | 2.02% |
|--|--------|-------|-------|-------|-------|

COLLECTIONS 2005 TO PRESENT: **\$33,550,491.10**

OVERALL PERCENTAGE GROWTH/(REDUCTION) FOR OCTOBER TO PRESENT: **-1.47%**

FISCAL YEAR END PERCENTAGE (POS- OCTOBER TO SEPTEMBER)
Shown Once A Year on November Report.

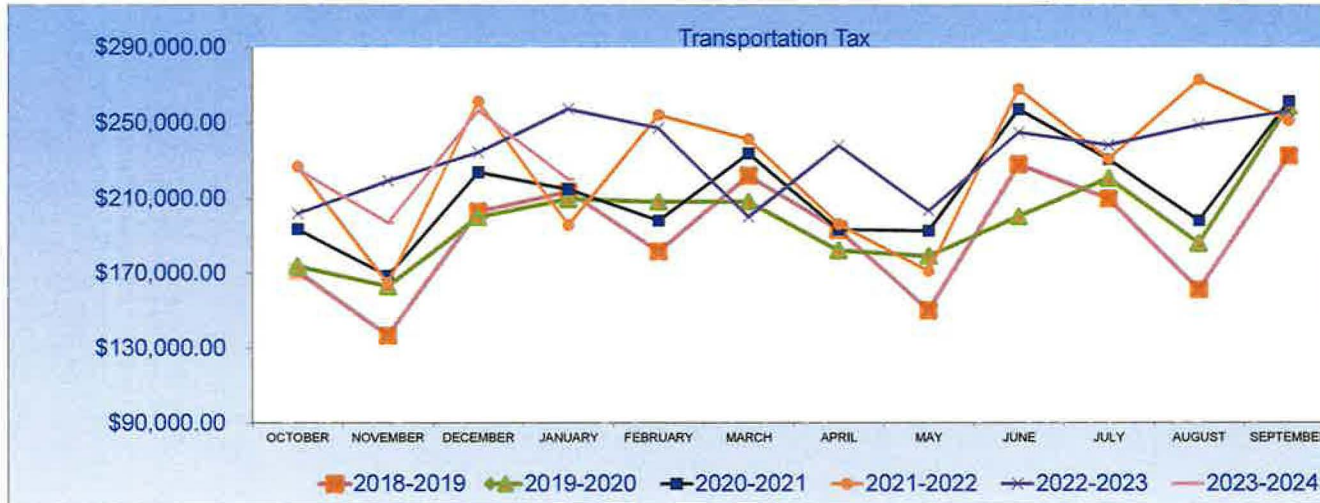

LOCAL OPTION USE TAX

| MONTH | 2018-2019 | 2019-2020 | 2020-2021 | 2021-2022 | 2022-2023 | 2023-2024 | Monthly % Increase/ (Decrease) |
|--------------|----------------------|----------------------|----------------------|------------------------|------------------------|----------------------|--------------------------------------|
| OCTOBER | \$ 34,224.58 | \$ 35,500.86 | \$ 70,550.86 | \$ 73,349.35 | \$ 80,047.64 | \$ 116,786.38 | 45.90% |
| NOVEMBER | 48,613.78 | 56,442.98 | 77,752.19 | 75,696.93 | 134,689.97 | 99,326.86 | -26.26% |
| DECEMBER | 49,662.96 | 53,993.39 | 65,391.95 | 81,034.55 | 150,460.10 | 173,869.84 | 15.56% |
| JANUARY | 68,775.33 | 39,958.65 | 69,783.79 | 98,017.42 | 108,564.38 | 118,355.41 | 9.02% |
| FEBRUARY | 73,271.71 | 63,549.19 | 112,976.86 | 102,284.34 | 150,469.87 | | |
| MARCH | 79,877.50 | 81,178.43 | 104,092.21 | 99,642.15 | 88,685.96 | | |
| APRIL | 54,168.57 | 51,201.38 | 83,105.78 | 117,044.07 | 142,947.05 | | |
| MAY | 45,391.56 | 117,142.50 | 70,120.42 | 155,677.22 | 86,607.84 | | |
| JUNE | 51,449.73 | 94,813.67 | 73,348.19 | 90,619.63 | 100,202.40 | | |
| JULY | 42,197.49 | 76,691.07 | 63,309.11 | 93,190.15 | 155,042.94 | | |
| AUGUST | 53,911.53 | 82,028.64 | 89,259.01 | 211,885.73 | 216,974.72 | | |
| SEPTEMBER | 62,998.22 | 79,946.63 | 109,517.43 | 121,402.30 | 138,127.68 | | |
| TOTAL | \$ 664,542.96 | \$ 832,447.39 | \$ 989,207.80 | \$ 1,319,843.84 | \$ 1,552,820.55 | \$ 508,338.49 | |

Increase
(Decrease)
Over Prior
Year

5.46% 25.27% 18.83% 33.42% 17.65%

COLLECTIONS 1998 TO PRESENT: **\$ 13,185,770.63**

OVERALL PERCENTAGE
GROWTH/(REDUCTION) FOR
OCTOBER TO PRESENT: **7.30%**

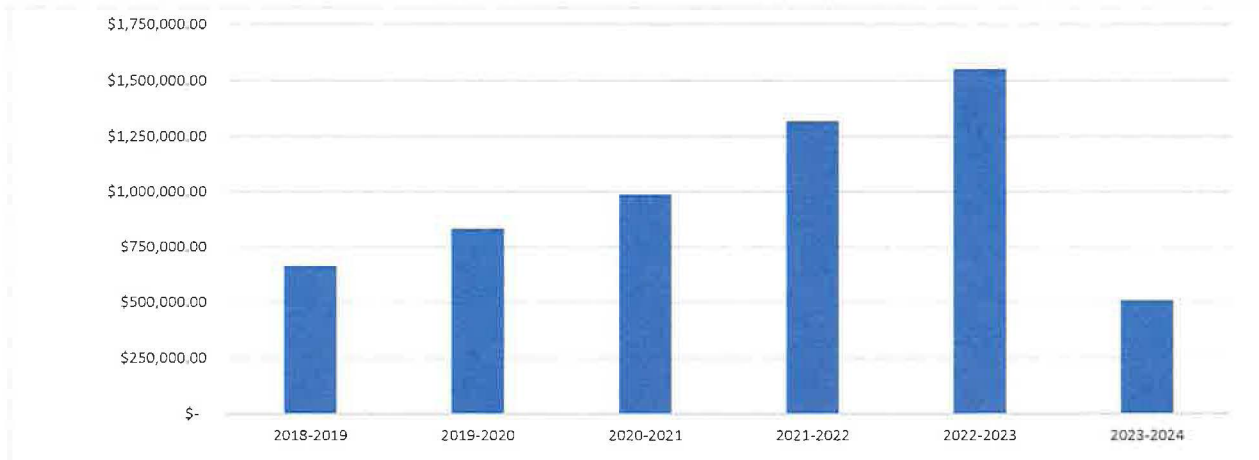



| Account Typ... | Original Total Budget | Current Total Budget | Period Activity | Fiscal Activity | Variance Favorable (Unfavorable) | Percent Remaining |
|---|--------------------------|-------------------------|--------------------|----------------------|--|----------------------|
| Fund: 001 - GENERAL FUND | | | | | | |
| Revenue | 17,043,890.00 | 17,043,890.00 | 804,942.17 | 6,698,453.05 | -10,345,436.95 | 60.70% |
| Expense | 17,774,520.00 | 17,779,520.00 | 814,396.39 | 4,793,047.57 | 12,986,472.43 | 73.04% |
| Fund: 001 - GENERAL FUND Surplus (Deficit): | -730,630.00 | -735,630.00 | -9,454.22 | 1,905,405.48 | 2,641,035.48 | 359.02% |
| Fund: 003 - LIBRARY FUND | | | | | | |
| Revenue | 813,880.00 | 813,880.00 | 10,856.74 | 580,307.19 | -233,572.81 | 28.70% |
| Expense | 898,840.00 | 898,840.00 | 60,178.83 | 237,434.29 | 661,405.71 | 73.58% |
| Fund: 003 - LIBRARY FUND Surplus (Deficit): | -84,960.00 | -84,960.00 | -49,322.09 | 342,872.90 | 427,832.90 | 503.57% |
| Fund: 004 - VOLUNTEER FIRE FUND | | | | | | |
| Revenue | 1,010,070.00 | 1,010,070.00 | 37,044.41 | 43,228.92 | -966,841.08 | 95.72% |
| Expense | 1,345,860.00 | 1,351,680.00 | 29,128.96 | 487,352.67 | 864,327.33 | 63.94% |
| Fund: 004 - VOLUNTEER FIRE FUND Surplus (Deficit): | -335,790.00 | -341,610.00 | 7,915.45 | -444,123.75 | -102,513.75 | -30.01% |
| Fund: 010 - VEHICLE & EQUIPMENT REPLACEMENT FUND | | | | | | |
| Revenue | 465,000.00 | 465,000.00 | 0.00 | 400,000.00 | -65,000.00 | 13.98% |
| Expense | 1,239,000.00 | 1,284,900.00 | 68,007.80 | 83,646.80 | 1,201,253.20 | 93.49% |
| Fund: 010 - VEHICLE & EQUIPMENT REPLACEMENT FUND Surplus (D... | -774,000.00 | -819,900.00 | -68,007.80 | 316,353.20 | 1,136,253.20 | 138.58% |
| Fund: 250 - STORMWATER IMPROVEMENT FUND | | | | | | |
| Revenue | 1,822,000.00 | 1,822,000.00 | 173,869.84 | 390,400.79 | -1,431,599.21 | 78.57% |
| Expense | 3,575,780.00 | 3,575,780.00 | 51,539.74 | 143,700.34 | 3,432,079.66 | 95.98% |
| Fund: 250 - STORMWATER IMPROVEMENT FUND Surplus (Deficit): | -1,753,780.00 | -1,753,780.00 | 122,330.10 | 246,700.45 | 2,000,480.45 | 114.07% |
| Fund: 260 - CAPITAL IMPROVEMENT SALES TAX FUND | | | | | | |
| Revenue | 4,564,150.00 | 4,564,150.00 | 237,156.94 | 629,157.64 | -3,934,992.36 | 86.22% |
| Expense | 6,582,850.00 | 7,113,560.00 | 16,270.50 | 321,919.07 | 6,791,640.93 | 95.47% |
| Fund: 260 - CAPITAL IMPROVEMENT SALES TAX FUND Surplus (Defic... | -2,018,700.00 | -2,549,410.00 | 220,886.44 | 307,238.57 | 2,856,648.57 | 112.05% |
| Fund: 261 - TRANSPORTATION SALES TAX FUND | | | | | | |
| Revenue | 8,305,690.00 | 8,305,690.00 | 373,686.33 | 899,262.85 | -7,406,427.15 | 89.17% |
| Expense | 10,073,530.00 | 10,593,080.00 | 67,999.22 | 3,163,848.30 | 7,429,231.70 | 70.13% |
| Fund: 261 - TRANSPORTATION SALES TAX FUND Surplus (Deficit): | -1,767,840.00 | -2,287,390.00 | 305,687.11 | -2,264,585.45 | 22,804.55 | 1.00% |
| Fund: 265 - COP FUND | | | | | | |
| Revenue | 2,117,900.00 | 2,117,900.00 | 0.00 | 1,955,903.87 | -161,996.13 | 7.65% |
| Expense | 2,167,400.00 | 2,167,400.00 | 0.00 | 0.00 | 2,167,400.00 | 100.00% |
| Fund: 265 - COP FUND Surplus (Deficit): | -49,500.00 | -49,500.00 | 0.00 | 1,955,903.87 | 2,005,403.87 | 4,051.32% |
| Fund: 272 - DOWNTOWN TIF RPA-1 | | | | | | |
| Revenue | 399,400.00 | 399,400.00 | 52,523.90 | 74,448.43 | -324,951.57 | 81.36% |
| Expense | 811,060.00 | 821,060.00 | 0.00 | 6,775.86 | 814,284.14 | 99.17% |
| Fund: 272 - DOWNTOWN TIF RPA-1 Surplus (Deficit): | -411,660.00 | -421,660.00 | 52,523.90 | 67,672.57 | 489,332.57 | 116.05% |
| Fund: 273 - FRONT & MAIN TIF RPA-3 | | | | | | |
| Revenue | 70,000.00 | 70,000.00 | 38,822.40 | 39,209.60 | -30,790.40 | 43.99% |
| Expense | 69,610.00 | 69,610.00 | 0.00 | 0.00 | 69,610.00 | 100.00% |
| Fund: 273 - FRONT & MAIN TIF RPA-3 Surplus (Deficit): | 390.00 | 390.00 | 38,822.40 | 39,209.60 | 38,819.60 | -9,953.74% |
| Fund: 274 - RHINE RIVER TIF RPA-2 | | | | | | |
| Revenue | 154,200.00 | 154,200.00 | 20,180.56 | 20,195.02 | -134,004.98 | 86.90% |
| Expense | 153,520.00 | 153,520.00 | 0.00 | 0.00 | 153,520.00 | 100.00% |
| Fund: 274 - RHINE RIVER TIF RPA-2 Surplus (Deficit): | 680.00 | 680.00 | 20,180.56 | 20,195.02 | 19,515.02 | -2,869.86% |
| Fund: 400 - WATER FUND | | | | | | |
| Revenue | 3,271,800.00 | 3,271,800.00 | 156,501.32 | 550,153.70 | -2,721,646.30 | 83.18% |
| Expense | 3,729,080.00 | 3,919,080.00 | 103,039.64 | 730,948.04 | 3,188,131.96 | 81.35% |
| Fund: 400 - WATER FUND Surplus (Deficit): | -457,280.00 | -647,280.00 | 53,461.68 | -180,794.34 | 466,485.66 | 72.07% |

Budget Report

For Fiscal: 2023-2024 Period Ending: 12/31/2023

| Account Typ... | Original Total Budget | Current Total Budget | Period Activity | Fiscal Activity | Variance Favorable (Unfavorable) | Percent Remaining |
|--|--------------------------|-------------------------|--------------------|---------------------|--|----------------------|
| Fund: 410 - SEWAGE TREATMENT FUND | | | | | | |
| Revenue | 3,284,870.00 | 3,284,870.00 | 216,184.97 | 659,246.22 | -2,625,623.78 | 79.93% |
| Expense | 6,189,000.00 | 6,189,000.00 | 210,934.69 | 456,692.13 | 5,732,307.87 | 92.62% |
| Fund: 410 - SEWAGE TREATMENT FUND Surplus (Deficit): | -2,904,130.00 | -2,904,130.00 | 5,250.28 | 202,554.09 | 3,106,684.09 | 106.97% |
| Fund: 420 - SOLID WASTE FUND | | | | | | |
| Revenue | 4,109,550.00 | 4,109,550.00 | 193,666.33 | 534,263.95 | -3,575,286.05 | 87.00% |
| Expense | 5,547,700.00 | 5,547,700.00 | 222,795.13 | 686,925.22 | 4,860,774.78 | 87.62% |
| Fund: 420 - SOLID WASTE FUND Surplus (Deficit): | -1,438,150.00 | -1,438,150.00 | -29,128.80 | -152,661.27 | 1,285,488.73 | 89.38% |
| Fund: 810 - PHOENIX CENTER II CID FUND | | | | | | |
| Revenue | 1,652,810.00 | 1,652,810.00 | 65,806.92 | 341,060.48 | -1,311,749.52 | 79.36% |
| Expense | 1,707,850.00 | 1,707,850.00 | 6,604.74 | 863,929.74 | 843,920.26 | 49.41% |
| Fund: 810 - PHOENIX CENTER II CID FUND Surplus (Deficit): | -55,040.00 | -55,040.00 | 59,202.18 | -522,869.26 | -467,829.26 | -849.98% |
| Report Surplus (Deficit): | -12,780,390.00 | -14,087,370.00 | 730,347.19 | 1,839,071.68 | 15,926,441.68 | 113.05% |

Fund Summary

| Fund | Original Total Budget | Current Total Budget | Period Activity | Fiscal Activity | Variance Favorable (Unfavorable) |
|----------------------------------|--------------------------|-------------------------|--------------------|---------------------|--|
| 001 - GENERAL FUND | -730,630.00 | -735,630.00 | -9,454.22 | 1,905,405.48 | 2,641,035.48 |
| 003 - LIBRARY FUND | -84,960.00 | -84,960.00 | -49,322.09 | 342,872.90 | 427,832.90 |
| 004 - VOLUNTEER FIRE FUND | -335,790.00 | -341,610.00 | 7,915.45 | -444,123.75 | -102,513.75 |
| 010 - VEHICLE & EQUIPMENT REPL | -774,000.00 | -819,900.00 | -68,007.80 | 316,353.20 | 1,136,253.20 |
| 250 - STORMWATER IMPROVEMEI | -1,753,780.00 | -1,753,780.00 | 122,330.10 | 246,700.45 | 2,000,480.45 |
| 260 - CAPITAL IMPROVEMENT SAL | -2,018,700.00 | -2,549,410.00 | 220,886.44 | 307,238.57 | 2,856,648.57 |
| 261 - TRANSPORTATION SALES TA | -1,767,840.00 | -2,287,390.00 | 305,687.11 | -2,264,585.45 | 22,804.55 |
| 265 - COP FUND | -49,500.00 | -49,500.00 | 0.00 | 1,955,903.87 | 2,005,403.87 |
| 272 - DOWNTOWN TIF RPA-1 | -411,660.00 | -421,660.00 | 52,523.90 | 67,672.57 | 489,332.57 |
| 273 - FRONT & MAIN TIF RPA-3 | 390.00 | 390.00 | 38,822.40 | 39,209.60 | 38,819.60 |
| 274 - RHINE RIVER TIF RPA-2 | 680.00 | 680.00 | 20,180.56 | 20,195.02 | 19,515.02 |
| 400 - WATER FUND | -457,280.00 | -647,280.00 | 53,461.68 | -180,794.34 | 466,485.66 |
| 410 - SEWAGE TREATMENT FUND | -2,904,130.00 | -2,904,130.00 | 5,250.28 | 202,554.09 | 3,106,684.09 |
| 420 - SOLID WASTE FUND | -1,438,150.00 | -1,438,150.00 | -29,128.80 | -152,661.27 | 1,285,488.73 |
| 810 - PHOENIX CENTER II CID FUNI | -55,040.00 | -55,040.00 | 59,202.18 | -522,869.26 | -467,829.26 |
| Report Surplus (Deficit): | -12,780,390.00 | -14,087,370.00 | 730,347.19 | 1,839,071.68 | 15,926,441.68 |

13e